OPERATION MANUAL

TH2840 Series

Automatic Transformer Test System

Changzhou Tonghui Electronic Co.,Ltd.

www.tonghui.com.cn

Contents

Chapter 1	Out of Box Audit.....	1
1.1	To Inspect the package.....	1
1.2	Power connection.....	1
1.3	Fuse	1
1.4	Environment.....	1
1.5	Use of Test Fixture	2
1.6	Warm-up	2
1.7	Safety Requirements.....	2
1.7.1	Insulation Resistance.....	2
1.7.2	Dielectric Strength.....	3
1.7.3	Leakage Current.....	3
1.8	Electromagnetic Compatibility Requirements.....	3
1.9	Other characteristics of the equipment.....	3
Chapter 2	Introduction.....	4
2.1	Introduction to front panel.....	4
2.2	Introduction to rear panel.....	6
2.2.1	Rear panel description 1.....	6
2.2.2	Rear panel description 2.....	8
2.3	Introduction to display zone.....	9
2.4	Main menu keys and corresponding displayed pages.....	10
2.4.1	[DISP]	10
2.4.2	[SETUP].....	10
2.4.3	[SYSTEM]	11
2.5	Basic Operation.....	11
2.6	Power on and off.....	11
Chapter 3	Description of LCR Function Module	13
3.1	<Meas Display>.....	13
3.1.1	Common test conditions.....	13
3.1.2	Test function.....	13
3.1.3	Scaling position.....	14
3.1.4	Result display of bin sort.....	15
3.1.5	Save the bridge test results on the USB flash drive.....	16
3.2	<List Display>.....	16
3.2.1	USB flash drive data save	17
3.3	<Trace Display>.....	18
3.3.1	Trigger.....	18
3.3.2	Scale	18
3.3.3	Extreme Values.....	19
3.3.4	Coordinate Format	19
3.3.5	Read	19
3.3.6	Trace.....	20
3.3.7	USB flash drive data save	22

3.3.8	Other test results.....	22
3.4	<Meas Setup>.....	23
3.4.1	Test function.....	23
3.4.2	Frequency.....	24
3.4.3	Level.....	25
3.4.4	Speed.....	26
3.4.5	Range.....	26
3.4.6	DC Bias.....	27
3.4.7	Level monitor function.....	28
3.4.8	Trigger.....	28
3.4.9	Average.....	29
3.4.10	Automatic level control.....	29
3.4.11	Source resistance.....	30
3.4.12	Deviation and reference.....	30
3.5	<Limit Setup>.....	31
3.5.1	Compare switch.....	31
3.5.2	Compare count switch.....	32
3.5.3	Comparison function limit mode.....	32
3.5.4	Compare parameters.....	33
3.5.5	Deviations and references.....	33
3.5.6	BIN Switch.....	33
3.5.7	High-low limit.....	33
3.6	<List Setup>.....	33
3.6.1	Total Point.....	34
3.6.2	Trigger mode.....	34
3.6.3	List mode.....	35
3.6.4	Difference Mode.....	35
3.6.5	Sweep condition.....	35
3.6.6	Parameter function.....	36
3.6.7	High/low limit.....	36
3.6.8	Comparison.....	36
3.6.9	Delay.....	37
3.7	Trace Setup.....	37
3.7.1	Common test conditions.....	37
3.7.2	4 sweep parameters.....	37
3.7.3	Spilt.....	38
3.7.4	Sweep point.....	38
3.7.5	Sweep Type.....	38
3.7.6	Trace mode.....	38
3.7.7	X Format.....	39
3.7.8	Max-Min.....	39
3.7.9	Curve Comparison Configuration.....	39
3.8	User Correction.....	40
3.8.1	Open.....	40

3.8.2	Short.....	42
3.8.3	Load	43
3.8.4	Load type.....	43
3.8.5	Cable	44
3.8.6	Point frequency operation	44
3.9	Handler Settings.....	45
Chapter 4	System and File	46
4.1	<System Setup>.....	46
4.1.1	Mode Setup	46
4.1.2	User Setup	47
4.1.3	RS232.....	48
4.1.4	LAN	49
4.1.5	Tools.....	50
4.2	<File>.....	51
4.2.1	U-disk manage performance	52
4.2.2	Introduction to Store/Recall Function	52
4.2.3	Basic menu operation of file management	53
4.2.4	Operation steps for file management	54
Chapter 5	Execute LCR measurement operation and some examples.....	56
5.1	Correction operation.....	56
5.1.1	Sweep correction.....	56
5.1.2	Point-frequency correction.....	56
5.2	Correct connection of DUT.....	57
5.3	Operation example for testing inductance.....	58
5.3.1	Test Condition	58
5.3.2	Operation steps.....	58
5.4	Operation example of testing capacitance by multi-frequency list sweep.....	59
5.4.1	Test condition.....	59
5.4.2	Operation steps.....	59
5.5	Operation example of load correction.....	60
5.5.1	Operation steps.....	60
5.5.2	Note.....	61
Chapter 6	Transformer Single-machine Test	62
6.1	Circuit for transformer single-machine test.....	62
6.1.1	Some parameters of transformer	62
6.1.2	Transformer single test circuit and TURN test.....	62
6.1.3	Transformer leakage inductance test.....	63
6.1.4	Capacitance test between windings of transformer	63
6.2	<Transformer Single Setup>.....	64
6.2.1	Trigger.....	64
6.2.2	Speed.....	64
6.2.3	Test Mode.....	64
6.2.4	Rsou	65
6.2.5	Bias Source.....	65

6.2.6	Comp	65
6.2.7	Parameter Setup	65
6.3	<Single Display>	66
6.3.1	Save the test results of a single set of transformers on the USB flash drive	67
Chapter 7	Transformer Auto Scanning Test.....	68
7.1	Introduction to scan test function	68
7.2	Install and connect the scanning test system.....	68
7.3	Front panel of scanning box	69
7.4	Rear panel of scanning box.....	71
7.5	HANDLER interface.....	71
7.5.1	Timing diagram of HANDLER signal	71
7.5.2	Distribution and connection diagram for HANDLER.....	71
7.6	Example of transformer	72
7.7	Clear Settings.....	73
7.8	<Transformer ID>	73
7.8.1	Transformer ID.....	74
7.8.2	Primary Nums	74
7.8.3	Secondary Nums	74
7.8.4	Rescan Interval.....	74
7.8.5	Scan Disp Mode	74
7.8.6	Fail Rescan.....	75
7.8.7	Bias On Delay	75
7.8.8	Ignore Nom	75
7.8.9	Trigger Delay	75
7.8.10	Cylinder Ctrl.....	76
7.8.11	Scan Box Mode	76
7.8.12	Resistance Source.....	76
7.8.13	Bias Source.....	76
7.9	Trans Pin To Fixture.....	77
7.9.1	Pin To Fixture Setup.....	77
7.9.2	Pin Label Setup	78
7.10	Pin Setup	78
7.10.1	Trans Pin Setup	79
7.10.2	Series Pins Setup.....	80
7.10.3	Parallel Pins Setup.....	80
7.11	<Trans Condition>	81
7.11.1	Frequency, voltage, switch and scanning sequence.....	81
7.11.2	TURN Test Conditions Setup.....	82
7.11.3	Lx Test Conditions Setup	85
7.11.4	Lk Test Conditions Setup	88
7.11.5	Cx Test Conditions Setup.....	90
7.11.6	Zx Test Conditions Setup	94
7.11.7	ACR Test Conditions Setup	96
7.11.8	DCR Test Conditions Setup	98

7.11.9	PS Test Conditions Setup	99
7.11.10	BL Test Conditions Setup.....	101
7.11.11	Handler Mode Function	103
7.11.12	Parameter copy function.....	104
7.11.13	Statistics Page.....	104
7.12	<Trans Scan>	105
7.12.1	Each Display Zone under this page.....	105
7.12.2	Function Keys under this page.....	106
7.12.3	PRI page-turning function.....	106
7.12.4	Pin Display Function for Stray Capacitance	107
7.12.5	BAL Balance parameter display.....	108
7.13	<File> page of Transformer Scan.....	108
7.13.1	Transformer scan setup file (*.t40)	108
7.13.2	Operation steps for file manage	109
7.13.3	Transformer deviation-deduction	110
7.14	Focus.....	111
7.15	Split.....	112
7.16	Frequently asked questions and answers in transformer scan test	113
7.16.1	High and low limits.....	113
7.16.2	Measurement item loss.....	113
7.16.3	Measurement interruption	113
7.16.4	Poor DCR accuracy.....	114
7.16.5	Poor Lk accuracy.....	114
7.16.6	Inaccurate TURN	114
7.16.7	Unstable TURN.....	114
7.16.8	Difference between the first and the second Lx	114
7.16.9	Poor stability of Cx and Zx open test data	115
7.16.10	DCR and PS open cannot reach infinite large	115
7.17	User-made test fixture.....	115
7.17.1	Use TH1801-EXT2A-OUT to make test fixture	115
7.17.2	Example of using TH1801-EXT11A(5.0)-B pin signal	116
Chapter 8	Performance and Test.....	117
8.1	Test function.....	117
8.1.1	Parameter and symbol.....	117
8.1.2	Test combination	118
8.1.3	Mathematical operation.....	118
8.1.4	Equivalent mode.....	118
8.1.5	Range	118
8.1.6	Trigger.....	118
8.1.7	Delay time	118
8.1.8	Connection modes of test terminals	119
8.1.9	Test speed (Frequency>=10kHz)	119
8.1.10	Average	119
8.1.11	Display digit.....	119

8.2	Test signal.....	119
8.2.1	Test signal frequency.....	119
8.2.2	Signal mode.....	119
8.2.3	Test signal level.....	120
8.2.4	Output impedance	120
8.2.5	Monitor for test signal level	120
8.2.6	Maximum measurement display range.....	120
8.2.7	DC bias voltage source.....	120
8.2.8	2A Bias Current Source.....	121
8.3	Measurement accuracy.....	121
8.3.1	Accuracy of $ Z $, $ Y $, L, C, R, X, G, B	121
8.3.2	D accuracy.....	121
8.3.3	Q accuracy.....	122
8.3.4	Θ accuracy.....	122
8.3.5	G accuracy.....	122
8.3.6	R _p accuracy.....	122
8.3.7	R _s accuracy	123
8.3.8	DCR accuracy	123
8.3.9	L _k accuracy	123
8.3.10	Turns Ratio accuracy.....	123
8.3.11	Accuracy factorFigure A.....	123
8.4	Performance test.....	127
8.4.1	Working condition.....	127
8.4.2	The used instruments and devices	127
8.4.3	Function check	128
8.4.4	Test signal level.....	128
8.4.5	Frequency.....	128
8.4.6	Measurement accuracy.....	128
8.4.7	Accuracy of C and D.....	128
8.4.8	Accuracy of L.....	129
8.4.9	Accuracy of Z.....	129
8.4.10	Accuracy of DCR.....	129
Chapter 9	Command Reference.....	131
9.1	GPIB Common Commands.....	131
9.2	SCPI Command.....	132
9.2.1	DISPlay subsystem commands	134
9.2.2	FREQuency subsystem commands	135
9.2.3	VOLTage subsystem commands	135
9.2.4	CURRent subsystem commands	136
9.2.5	AMPLitude subsystem commands.....	136
9.2.6	OUTPut subsystem commands	137
9.2.7	BIAS subsystem commands.....	137
9.2.8	TRIGger subsystem commands	139
9.2.9	AMPLitude Auto Level subsystem commands	140

9.2.10	Output RESister Internal Resistance subsystem commands	141
9.2.11	FUNcTION subsystem commands	141
9.2.12	COMParator subsystem commands	145
9.2.13	LIST subsystem commands	148
9.2.14	TRAcE subsystem commands	157
9.2.15	HandlER subsystem commands	161
9.2.16	FETCh? subsystem commands	162
9.2.17	CORREction subsystem commands	166
9.2.18	Mass MEMory subsystem commands	171
9.2.19	TRAN subsystem commands	172
9.2.20	TRs Transformer Scan Command Set	178
9.2.21	SYSTem system subsystem commands	181
9.3	Modbus commands	185
9.3.1	Command format	185
9.3.2	CRC16 calculation method - look-up table method	187
9.3.3	Command function comparison table	189
9.4	Examples of Writing Commands	201
9.4.1	Example of Curve Scan Commands	201
9.4.2	Examples of Transformer Test Commands	202
Chapter 10	Description for Handler	204
10.1	Bin Sorting Handler Description	204
10.1.1	Technology Description	204
10.1.2	Electrical feature	208
10.1.3	Handler Wiring Operation Instructions of BIN Sorting	211
10.1.4	Using Operations	213
10.2	List Sweep Handler Description	214
10.2.1	List Sweep Sorting Logic	214
10.2.2	Technical Description	215
10.2.3	Electrical Feature	218
10.2.4	List sweep sorting wiring operation instructions	218
10.2.5	Using operation	218
10.3	HANDLER description of transformer single group test	219
10.3.1	Sorting logic	219
10.3.2	Technical description	219
10.3.3	Electrical Feature	221
10.3.4	Handler wiring operation instructions for transformer single measurement	222
10.3.5	Using Operation	222
10.4	Transformer scan HANDLER description	223
10.4.1	Technical Description	223
10.4.2	Electrical Feature	225
10.4.3	Handler wiring operation instructions for transformer Scan	229
10.4.4	Using operation	233
10.5	Instructions for HANDLER sorting of scanning fixtures	233
Chapter 11	Appendix	234

11.1	Warranty	234
------	----------------	-----

Chapter 1 Out of Box Audit

When you receive the instrument, some inspections are necessary, and the condition must be understood and available before installing the instrument.

1.1 To Inspect the package

Inspect the shipping container for damage after unpacking it. It is not recommended to power on the instrument in the case of a damaged container.

If the contents in the container do not conform to the packing list, notify us or your dealer.

1.2 Power connection

- 1) Power-supplying voltage range: 100~120Vac or 198~242Vac. Being related with the power setup on the rear panel.
- 2) Power-supplying frequency range: 47~63Hz.
- 3) Power-supplying power range: not less than 130VA.
- 4) Power supplying input phase line L, zero line N, ground lead E should be as same as the power plug of the instrument.
- 5) After careful design, the instrument can reduce the clutter jamming caused by AC power terminal input, however, it should be used under the environment with low-noise. Please install power filter if being unavoidable.

Warning: In order to prevent user and instrument from being hurt by leakage, it is necessary for user to guarantee the ground line of supply power being reliably grounded.

1.3 Fuse

The instrument has installed fuse, so operators should use the installed fuse of our company.

Warning: Be sure that the location of fuse is consistent with power-supplying voltage range before charging.

1.4 Environment

- 1) Please do not operate the instrument in the place that is vibrative, dusty, under direct sunlight

or where there is corrosive air.

- 2) The normal working temperature is $0^{\circ}\text{C} \sim 40^{\circ}\text{C}$, relative humidity $\leq 75\%$, so the instrument should be used under above condition to guarantee the accuracy.
- 3) There is heat abstractor on the rear panel to avoid the inner temperature rising. In order to keep good airiness, please don't obstruct the left and right airiness holes to make the instrument maintain the accuracy.
- 4) Although the instrument has been specially designed for reducing the noise caused by ac power, a place with low noise is still recommended. If this cannot be arranged, please make sure to use power filter for the instrument.
- 5) Please store the instrument in the place where temperature is between 5°C and 40°C , humidity is less than 85%RH. If the instrument will not be put in use for a time, please have it properly packed with its original box or a similar box for storing.
- 6) The instrument, especially the test cable should be far from strong electro-magnetic field, to avoid the jamming on measurement.

1.5 Use of Test Fixture

Please use the accessory test fixture or cable, **the test fixture made by user or from other company may cause the incorrect measurement result**. The test fixture or cable should be kept clean, as well as the pin of DUT, thus to guarantee the good connection between DUT and fixture.

Connect the fixture or cable to four test terminals Hcur, Hpot, Lcur, Lpot on the front panel. As for the DUT with shielding shell, connect shielding layer or ground “ \perp ”.

Note: When test fixture or cable has not being installed, the instrument will display an unstable test result.

1.6 Warm-up

- 1) To guarantee the accurate measurement, the warm-up time is no less than 30 minutes.
- 2) Please not turn on or off instrument frequently, in order to avoid the inner data fluster.

1.7 Safety Requirements

The measuring instrument is a Class I safety instrument.

1.7.1 Insulation Resistance

Under reference operating conditions, the insulation resistance between the power terminal and the case shall be not less than 50 M Ω .

Under hot and humid transport conditions, the insulation resistance between the power terminal and the case shall be not less than 2 M Ω .

1.7.2 Dielectric Strength

Under reference operating conditions, the power terminals and case shall withstand an alternating voltage of 1.5 kV at a frequency of 50 Hz for 1 minute. There shall be no breakdown or arcing.

1.7.3 Leakage Current

The leakage current shall not exceed 3.5 mA (rms value of the alternating current).

1.8 Electromagnetic Compatibility Requirements

Conforms to Directive 2006/95/EC Safety requirements

EN 61010-1:2010+A1:2019 Safety requirements for electrical equipment for measurement, control and laboratory use.

Electromagnetic Compatibility Requirements

According to Directive 2004/108/EC on electromagnetic compatibility

EN 61326-1:2021 Electromagnetic compatibility requirements for electrical equipment for measurement, control and laboratory use

1 CISPR 11:2015+A1:2016+A2:2019 Radiated and conducted emissions, Group 1, Class A

1 EN 61000-4-2:2009 Electrostatic discharge immunity

1 EN 61000-4-3:2020 Radiated, radio frequency, electromagnetic field immunity

1 EN 61000-4-4:2012 Electrical fast transient/burst immunity

1 EN 61000-4-5:2014+A1:2017 Surge immunity for power supply lines

EN 61000-4-6:2014 Conducted radio frequency immunity

EN 61000-4-11:2020 Voltage dips and interruptions immunity

EN 61000-3-2:2019+A1:2021 Harmonic emission for AC power supply lines

EN 61000-3-3:2013+A1:2019+A2:2021 Voltage variations, fluctuations and flicker

1.9 Other characteristics of the equipment

Power consumption: Power consumption \leq 130VA.

Dimensions (W*H*D):

TH2840A, TH2840B, TH2840AX, TH2840BX: 430mm*177mm*265mm.

TH2840NX: 430mm*177mm*405mm

Weight: TH2840A, TH2840B, TH2840AX, TH2840BX Approx. 11kg;

TH2840NX about 17kg.

Chapter 2 Introduction

In this chapter, the basic operation features of TH2840 series are described. Please read the content carefully before using TH2840X series instruments.

2.1 Introduction to front panel

Figure 2-1 shows the front panel of TH2840 Series.

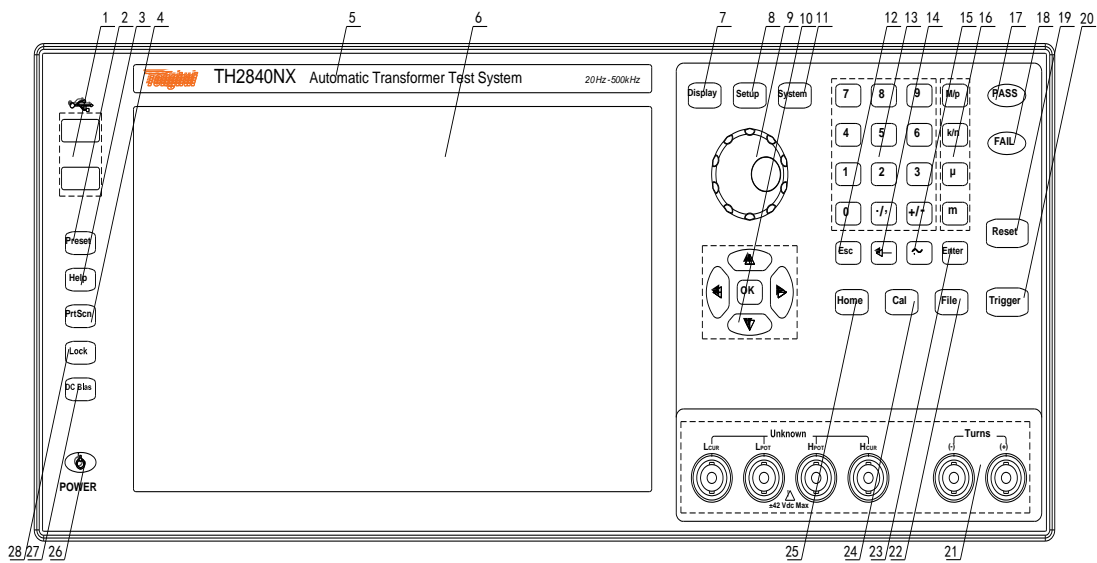

Figure 2-1 Front panel

- 1) USB HOST interface
TH2840 is equipped with two USB HOST interfaces, which are used to connect U disk storage for file saving and recall, and it can also connect to devices such as mouse, keyboard, and scanner. Note that only one U disk storage can be inserted at the same time.
- 2) [Preset] key
Reset button, press [Preset] to restore the instrument to the factory default settings.
- 3) [Help] key
Help key. Press the [Help] key, the [Help] key will be lit, and the display will pop up the function meaning and operation instructions where the cursor is located. Press the [Help] button again, the [Help] button will go out, and the operation instruction window will disappear.
- 4) [PrtScn] key
Screenshot button, save the picture of the current interface to the USB storage.
- 5) Brand and model
Brand and model
- 6) LCD liquid crystal display
1280x800 color LCD capacitive touch screen, showing the measurement results and conditions.

-
- 7) [Display] menu
Press the [Display] key to enter the corresponding test display page of the meter function (bridge, transformer measurement, transformer scan, focus scan).
 - 8) [SETUP] menu
Press the [Setup] key to enter the corresponding test setting page of the meter function (bridge, transformer measurement, transformer scan).
 - 9) Knob with confirmation function
Move the cursor, select and set parameters. The confirm button function in the middle is used to terminate data input, confirm and save the data input by the knob.
 - 10) Cursor keys and OK key
The cursor keys are composed of up (↑), down (↓), left (←) and right (→), which are used to move the cursor between the fields on the LCD display page. When the cursor moves to a certain field, the field will be highlighted on the LCD screen. The middle of the cursor keys is the OK key, and its function is similar to the [Enter] key.
 - 11) [SYSTEM]
Press this key to enter into the system setup page.
 - 12) [ESC] key
ESCAPE key.
 - 13) Numeric key
The numeric keys are used to input data to the instrument. The numeric keys are composed of numeric keys [0] to [9], decimal point [./,] and [+/-] keys.
 - 14) [←] key
Backspace key. Press this key to delete the last digit of the entered value.
 - 15) [~] key
This button is only used in transformer scan, and is used for continuous input of pins.
 - 16) Magnitude key
The magnitude key is used to input the magnitude of the corresponding parameter.
 - 17) PASS indicator
LED indicator shows the test result has passed.
 - 18) FAIL indicator
LED indicator shows the test result has failed.
 - 19) [Reset] key
Press the [Reset] key to pause the scan in the list scan and trace scan of the bridge, and press the [Trigger] key again to continue the scan from the previous pause. In the automatic transformer scan, press the [Reset] key to stop the scan and the next trigger will start from the beginning.
 - 20) [Trigger] key
When the trigger mode is set to Single mode, press this key to trigger the instrument.
 - 21) Test terminals (UNKNOWN)
4-terminal test pair are used to connect 4-terminal test fixture or cable to measure DUT.
The 4 terminals are respectively as follows: Hcur, Hpot, Lpot and Lcur.
Transformer secondary test terminal (TURNS)
(+): Secondary (+) terminal
(-): Secondary (-) terminal

NOTE: TH2840A and TH2840B have no transformer secondary measuring terminal.

- 22) [File] key
This key is used to enter into FILE MANAGE interface quickly.
- 23) [Enter] key
[Enter] key is used to terminate data input, confirm and save the data displayed in the input line.
- 24) [Cal] key
User calibration execution shortcut keys.
- 25) [Home] key
The [Home] key is used to switch between different functions such as electric bridge, transformer single-group test, and transformer scan.
- 26) POWER
Power switch. The instrument is red in the standby state and green in the power-on state. To shut down, you need to press and hold the power switch.
- 27) [DC Bias] key
[DC Bias] key is used to allow or prohibit the output of 0-100mA, $\pm 40V$, 0-2A DC bias source. Press the [DC Bias] key, the [DC Bias] key will be lit, indicating that the DC bias output is allowed; press the [DC Bias] key again, the [DC Bias] key will go out, indicating that the DC bias output is prohibited. In some non-test screens where DC Bias cannot be added, pressing this button will have no response.
- 28) [LOCK] key
Press the [LOCK] key, the [LOCK] key will be lit, indicating that the key functions of the current panel are locked; press the [LOCK] key again, the [LOCK] key will be off, indicating that the keyboard lock state is released. If the password function is set to "ON", the correct password must be entered when unlocking the keyboard, otherwise the keyboard lock cannot be unlocked.
When the instrument is controlled by RS232, USB_Device, Lan port, etc., the [LOCK] button will be lit. Press the [LOCK] key again, the [LOCK] key will go out, indicating that it returns to the local unlocked state of the keyboard.

2.2 Introduction to rear panel

The rear panels of different models of TH2840 series are different. The detailed description of the rear panel layout of TH2840A, TH2840B, TH2840AX, TH2840BX will be introduced in 2.2.1 and the detailed description of the rear panel layout of TH2840NX will be introduced in 2.2.2.

2.2.1 Rear panel description 1

Figure 2-2 briefly describes the rear panel of TH2840A, TH2840B, TH2840AX, and TH2840BX.

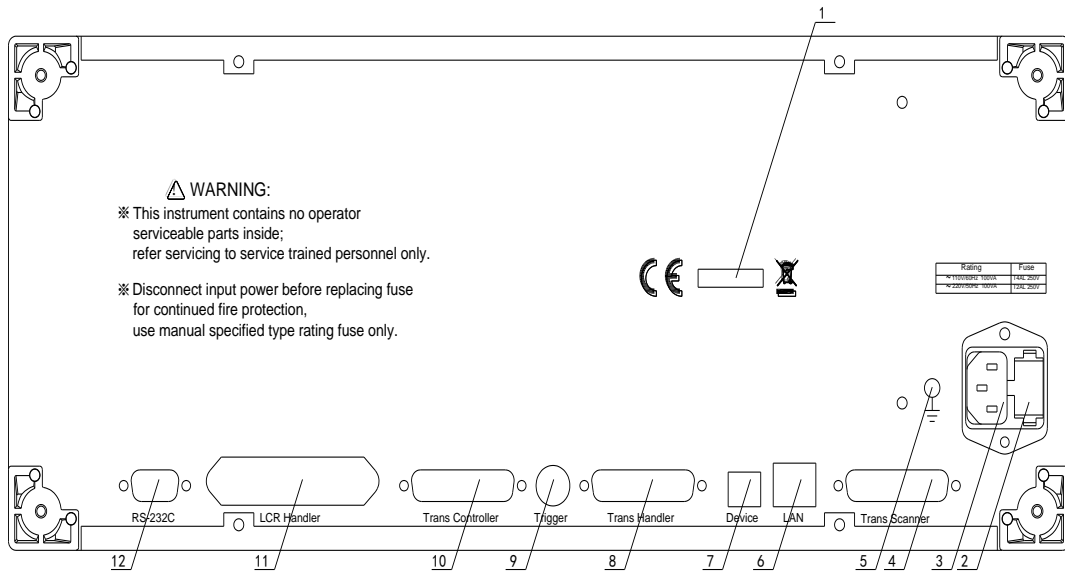

Figure 2-2 Rear panel

- 1) Nameplate
Indicate production date, instrument number, manufacturer and other information.
- 2) Fuse base
Being used to install power fuse, protect instrument, and switch 110V/220V by changing the direction of core.
- 3) Power socket
Input AC power.
Warning: Before powering on, pay attention to whether your fuse position is consistent with the supply voltage range.
- 4) TransScanner interface
To control the transformer scanning box through the Trans Scanner interface. It is compatible with TH1901 and TH1831 scanning boxes, but different scanning boxes require different connection cables.
Tip: TH2840A and TH2840B have no transformer scan function, so this interface cannot be used.
- 5) Ground terminal
This terminal is connected to the chassis of the instrument. It can be used to protect or shield ground connections.
- 6) LAN interface
LAN interface is used to realize the control and the communication of network system.
- 7) USB Device interface
The tester can communicate with PC through the USB Device interface.
- 8) Trans Handler interface
The Handler interface of the transformer scan to realize the sorting output of the transformer scan results.
- 9) TRIGGER interface
External trigger devices such as foot control can be connected.
- 10) Trans Controller interface

The Handler extension interface of transformer scanning. When the number of sorting signals of the transformer scanning Handler interface is insufficient, this interface can be used to expand the sorting signal and realize the sorting output of the transformer scanning result.

11) LCR HANDLER interface

The Handler interface can realize the sorting output of the test results. This interface is used for the sorting of the single-group test of the bridge and the transformer.

12) RS232C serial interface

The serial communication interface can realize the online communication with the computer.

2.2.2 Rear panel description 2

Figure 2-3 briefly describes the rear panel of TH2840NX.

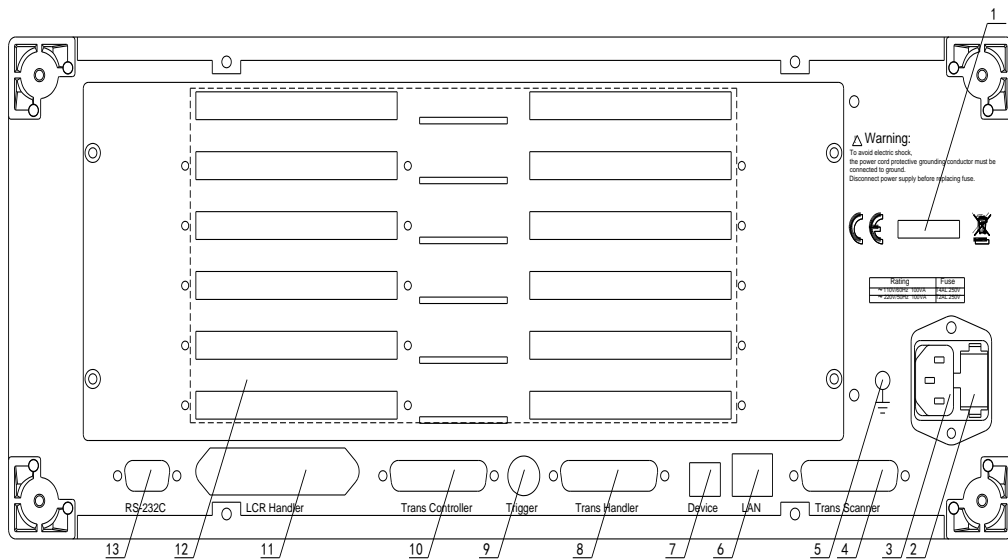

Figure 2-3 Rear panel

1) Nameplate

Indicate production date, instrument number, manufacturer and other information.

2) Fuse base

Being used to install power fuse, protect instrument, and switch 110V/220V by changing the direction of core.

3) Power socket

Input AC power.

Warning: Before powering on, pay attention to whether your fuse position is consistent with the supply voltage range.

4) TransScanner interface

To control the transformer scanning box through the Trans Scanner interface. It is compatible with TH1901 and TH1831 scanning boxes, but different scanning boxes require different connection cables.

5) Ground terminal

This terminal is connected to the chassis of the instrument. It can be used to protect or shield ground connections.

- 6) LAN interface
LAN interface is used to realize the control and the communication of network system.
- 7) USB Device interface
The tester can communicate with PC through the USB Device interface.
- 8) Trans Handler interface
The Handler interface of the transformer scan to realize the sorting output of the transformer scan results.
- 9) TRIGGER interface
External trigger devices such as foot control can be connected.
- 10) Trans Controller interface
The Handler extension interface of transformer scanning. When the number of sorting signals of the transformer scanning Handler interface is insufficient, this interface can be used to expand the sorting signal and realize the sorting output of the transformer scanning result.
- 11) LCR HANDLER interface
The Handler interface can realize the sorting output of the test results. This interface is used for the sorting of the single-group test of the bridge and the transformer.
- 12) Scanning cable interface
Scanning cable interface uses FRC-50P horn socket.
- 13) RS232C serial interface
The serial communication interface can realize the online communication with the computer.

2.3 Introduction to display zone

TH2840 uses a 10.1-inch capacitive touch screen, and the content displayed on the screen is divided into the following display areas, as shown in Figure 2-4.



The element composition of this page includes: title area, test condition area, 4 parameter result display area, sorting result display area, menu area, title area, status bar.

2.4 Main menu keys and corresponding displayed pages

2.4.1 [DISP]

- When the LCR function is used, press this key to enter into the LCR measurement display page. The function pages of this part are (use the "touch screen" to select the following page functions, the same below):

<Meas Display>

<List Display>

<Trace Display >

<Save>

- When the transformer test function is used, press this key to enter into the transformer test display page. The function pages of this part are:

<Save>

- When the transformer scan function is used, press this key to enter into the transformer scan display page. The function pages of this part are:

<Pri.>

<Load Std>

<Deviation>

<Speed>

<Test Fail>

<Focus>

<Split>

<Save>

2.4.2 [SETUP]

- When the bridge function is used, it is used to enter the setting screen of the component test. The function pages of this part are:

<Meas Setup>

<Limit Setup>

<List Setup>

<Trace Setup>

<User Corr>

<Handler>

- When the transformer test function is used, it is used to enter each setting screen of the transformer test. The function pages of this part are:

<Single Setup>

<User Corr>

<Handler>

- When the transformer scan function is used, it is used to enter each setting screen of the transformer scan. The function pages of this part are:

<Trans ID>

<Pin To Fixture>
<Pin Setup>
<Condition>
<Copy>
<Handler Mode>
<Stat>
<Tools>

2.4.3 [SYSTEM]

- It is used to enter the system settings homepage. It is mainly about communication settings, user management settings, Handlers settings. The function pages of this part are:

<System Info>
<Message>
<System check>
<License>

2.5 Basic Operation

The basic operation is as follows:

- Use menu keys ([DISP], [SETUP], [SYSTEM]) and soft keys to select the desired page.
- Use the cursor keys ([←][→][↑][↓]), knob or directly touch the screen to move the cursor to the area you want to set. When the cursor moves to a certain area, the area will be highlighted. This area is the area where the cursor can be set.
- The corresponding soft key function of the domain where the current cursor is located will be displayed in the "soft key area". Select and press the desired soft key. Numeric keys, [←], magnitude keys and [Enter] keys are used for data input. When a number key is pressed, you can press the order key or the [Enter] key to end the data input.

2.6 Power on and off

Plug in 3-line power plug.

Caution: Keep the power-supply voltage and frequency conform to above specifications. Power input phase line L, zero line N, ground line E should be the same as that of the instrument.

TH2840 series instruments use soft switches. After plugging in the three-wire power supply, some indicators on the front panel will flash for a few seconds. After a few seconds, the power button will light up in red, and other buttons with LED indications will go out.

Power on: Press the power switch at the lower left corner of the front panel to turn on the instrument and display the startup screen. After the instrument is started, the power button lights up green. The power button of TH2840 series instrument has memory function.

Shutdown: After using the instrument, if you need to turn off the instrument, press and hold the power button at the lower left corner of the front panel to turn off the instrument. After turning off the instrument, the power button lights up in red, and the instrument is in the standby state. If you do

not use the instrument for a long time, please disconnect the power cord and store the instrument in the environment required by 1.4.

Note: The factory password is set for this series of products. The factory password is 2840. The user can reset the password according to his needs during the use. For details, please refer to the password item on the <System Setup> page.

Chapter 3 Description of LCR Function Module

3.1 <Meas Display>

When the LCR function is applied, press [DISP], the <Meas Display> page will be displayed on screen as shown in the following figure.



The element composition of this page includes: title area, test condition area, 4 parameter result display area, sorting result display area, menu area, title area, status bar.

3.1.1 Common test conditions

There are 9 cursor fields in the measurement condition area of this display page, they are:

- Frequency, Speed, DC Bias,
- AC level, AC range, Vm,
- DC level, DC range, Im.

Each control function domain will be described in detail on the <Meas Setup> page.

3.1.2 Test function

Touch the position of the parameter name in the test result area, and you can see the selection menu of the corresponding test function in the right menu area. Touch the corresponding selection area of the menu to complete the function setting of the specified parameter. The menu display is shown in Figure 3-1-2:

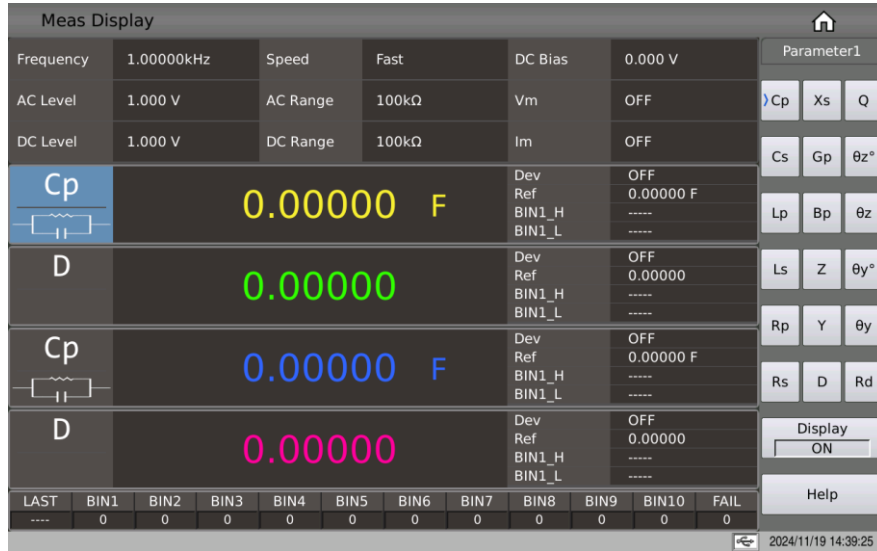

Figure 3-1-2 Parameter function setting

3.1.3 Scaling position

Parameter setting attributes: enumerated type.

The position of the decimal point has a direct relationship with the resolution of the result display, and the relative stability of the result can also be seen intuitively.

The principle of position movement is to ensure that the number of digits remains unchanged, with a certain decimal point on the left and right. As shown in Figure 3-1-3:



Figure 3-1-3 Movement of the decimal point

Setting options:

Menu options	Function description
Auto	The default setting item, which automatically displays the position of the decimal point
Fix	Used to fix the current decimal point position in the automatic state

Increase+	Move the decimal point to the left
Decrease-	Move the decimal point to the right

Note:

In the following cases, the decimal point position lock function will be automatically cancelled and restored to the floating decimal point display state.

Test function changes;

The deviation mode is changed.

3.1.4 Result display of bin sort

After touching or moving the cursor to the sorting result display area, the corresponding menu will involve some sorting controls, such as comparison switch, count switch, and count reset; as shown in Figure 3-1-4:



Figure 3-1-4 Quick settings for bin sorting

3.1.4.1 Comparison switch

The built-in comparison function of this series can divide the component under test into up to 11 bins (BIN1 to BIN10 and BIN OUT). 10 groups of upper and lower limits can be set, and the upper and lower limits of each file containing 4 parameters can be set independently. If one or more parameters are not involved in the comparison, then the corresponding upper and lower limits can be cleared. When the parameters of the DUT participating in the comparison are all within the range of the bin limit, the corresponding bin is found. The result of the sorting can be output to the automatic test system through the HANDLER interface to realize the automatic sorting test.

These limit settings can only be set on the <Limit Setup> page.

Optional setting of comparison function: on or off (ON or OFF), the default state is: OFF.

3.1.4.2 Bin count function

It is used to record and display the count value of each bin.

Optional setting of counting function: on or off (ON or OFF), the default state is: OFF.

3.1.4.3 Count reset

Perform a clearing operation on the count result of the current bin, so that the bin count is reset to 0, which is used to restart counting.

3.1.5 Save the bridge test results on the USB flash drive

Use the USB flash drive to save the test results.

The test results and formats that can be saved are as follows:

Time,P1,P2,P3,P4,BIN

----Respectively correspond to the test time, parameter 1~4 result, bin result

The states involved in data preservation are:

- Save the switch;
- Save path prompt, default path location: "usb/CSV/" path;
- The naming rule of the file name is rx+machine number+date, such as: rx-SN12345678-20210811.csv,

3.2 <List Display>

On the <List Setup> page, you can enter a test frequency of up to 201 points, test level, DC Bias, trigger delay, independent functions corresponding to 4 parameters, 4 independent parameters, and upper and lower limits corresponding to each list sweep test point. These test points will be automatically scanned and tested, and the test results will be compared with their corresponding limit values.

The test points on this display page will be automatically scanned and tested, and the test results are compared with the limit values. During the list sweep test, the leftmost symbol "*" indicates the current sweep test point. Display as shown in Figure 3-2-1:

Pt	Freq	Level	Bias	Para1	Para2	Para3	Para4	P/F
1	1.0000kHz	1.000 V	0.000 V					
2	1.0000kHz	1.000 V	0.000 V					
3	1.0000kHz	1.000 V	0.000 V					
4	1.0000kHz	1.000 V	0.000 V					
5	1.0000kHz	1.000 V	0.000 V					
6	1.0000kHz	1.000 V	0.000 V					
7	1.0000kHz	1.000 V	0.000 V					
8	1.0000kHz	1.000 V	0.000 V					

Figure 3-2-1 List display

The P/F on the far right (representing PASS/FAIL) is used to indicate the comparison result of the current point:

No comparison display: "---"

PASS display: PASS (green)

FAIL display: FAIL (red)

When the difference mode is turned on, the measurement results of parameters 3 and 4 are not displayed, and the difference calculation result of parameter 1 is displayed, as shown in Figure 3-2-2:

Pt	Freq	Level	Bias	Para1	Para2	Delta	P/F
1	1.0000kHz	1.000 V	0.000 V				
2	1.0000kHz	1.000 V	0.000 V				
3	1.0000kHz	1.000 V	0.000 V				
4	1.0000kHz	1.000 V	0.000 V				
5	1.0000kHz	1.000 V	0.000 V				
6	1.0000kHz	1.000 V	0.000 V				
7	1.0000kHz	1.000 V	0.000 V				
8	1.0000kHz	1.000 V	0.000 V				

3.2.1 USB flash drive data save

Use the USB flash drive to save the test results. The test results and formats that can be saved are as follows:

Time, pt, para1-4, P1,P2, P3, P4, COMP

---Respectively correspond to test time, point index, 4 parameter function, parameter 1~4 result, comparison result.

The states involved in data preservation are:

- Save the switch;
- Save path prompt, default path location: "usb/CSV/" path;
- The naming rule of the file name is list+machine number+date, such as: list-SN12345678-20210811.csv,

3.3 <Trace Display>

Press the menu key [Display], and then press the soft key Trace Display to enter the <Trace Display> page. As shown in Figure 3-3-1:

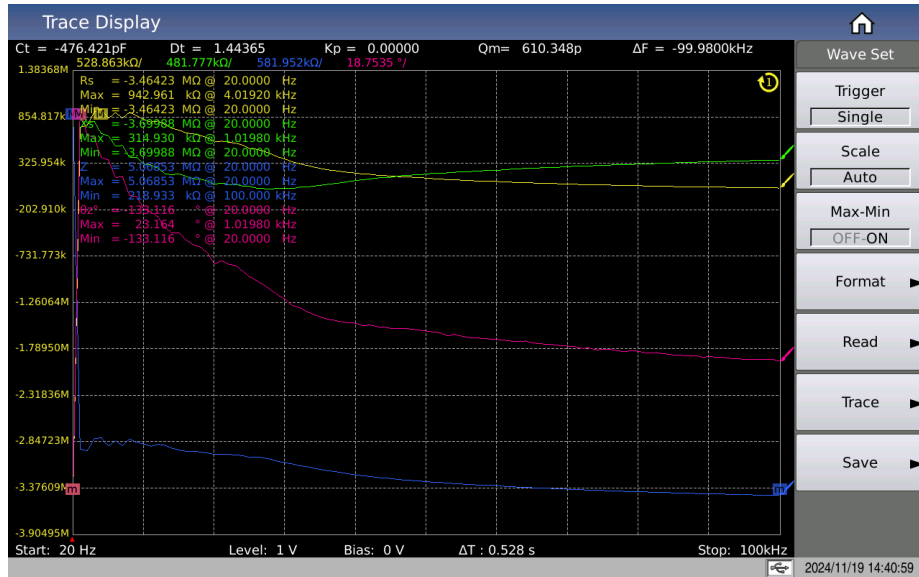

Figure 3-3-1 Trace display

In this display function page, each scan will perform automatic scan measurement of the tested component at 51, 101, 201, 401 or 801 point frequency in a linear or logarithmic manner with increasing conditions within the user preset mode range. Dynamic display of the response trace of the main and secondary parameters of the component under test with the change of the mode conditions on the LCD screen, the result of any point within the scanning range can be read on the screen. Simultaneously, the maximum and minimum measurement values and corresponding test conditions of the component under test within the scan range will be displayed.

Note: After the user has set the scanning conditions, the user must press the [Trigger] key on the front panel to start scanning. Press the [Reset] key once to pause the test, and press it again to reset and rescan.

3.3.1 Trigger

It is used to quickly set the trigger mode of the curve, refer to the trigger setup on the measurement setting page.

3.3.2 Scale

It is used to automatically set the Y-axis coordinate range corresponding to the curve. In the case of

Auto, the Y-axis scale range will be dynamically adjusted with the size range of the test result to ensure that the drawn curve is in the display range;

It is recommended that when the DUT is relatively stable, you can let the scale automatically select a relatively suitable scale range, and then set it to be fixed, and then manually press the up and down direction keys to fine-tune the display range according to the actual situation.

Parameter setting attributes: enumerated type.

Optional parameters:

Speed	Test times
Auto	The scale will adjust automatically
Fix	The scale is fixed, but can be adjusted manually

3.3.3 Extreme Values

Reference 3.7.8 Curve page Measurement parameter extreme value setting

3.3.4 Coordinate Format

You can set the format of the abscissa and ordinate of parameters 1 to 4 separately, linear or logarithmic. See 3.7.7 Graph page Display coordinate settings

3.3.5 Read

Condition setting for cursor reading

Cursor: It is a red line. You can observe the test results of different parameters under the same scanning condition by turning the knob or moving the left and right keys. As shown in Figure 3-3-2:

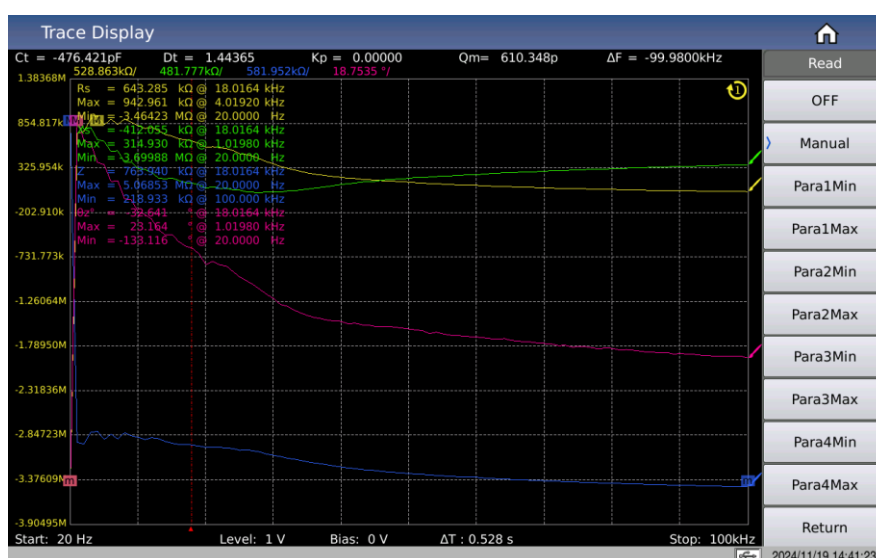

Figure 3-3-2 Read cursor display effect

Value description:

Read parameter options	Meaning
OFF	Cursor is not displayed
Manual	Manually adjust the cursor (knob and left and right keys)
Parameter 1/2/3/4	Automatically track the minimum or maximum value position of parameter 1/2/3/4
Minimum value	
Maximum value	

3.3.6 Trace

Through the submenu of the curve button, you can quickly set the sweep points of the curve, the curve display switch of 4 parameters, the split screen effect of the curve display and other related functions, as shown in Figure 3-3-3:

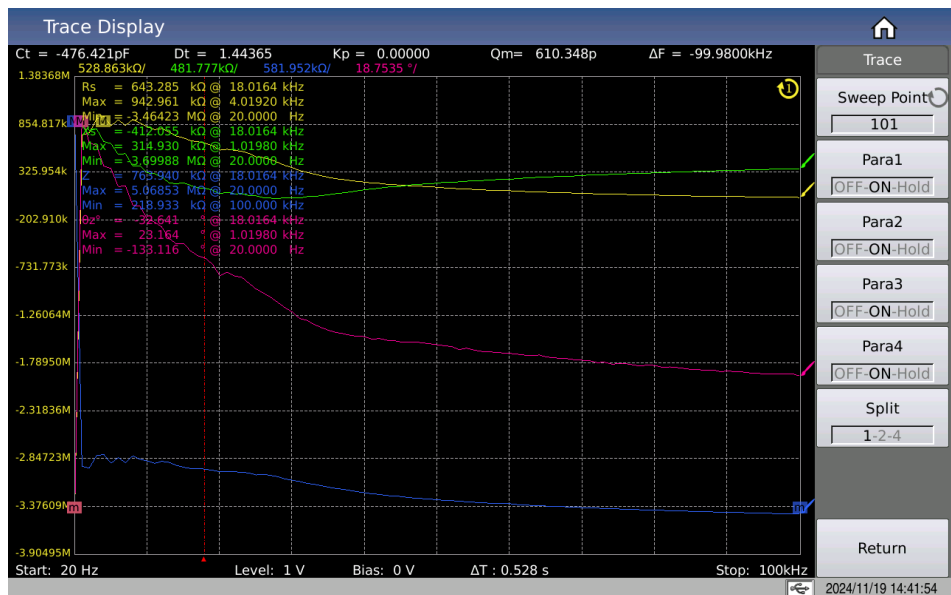

Figure 3-3-3 Curve button setting menu

3.3.6.1 Sweep point

This parameter controls the number of points the instrument scans. That is, the number of points to be stepped within the start and stop conditions. The system sets the number of measurement points in five groups: 51, 101, 201, 401, and 801. The more sweep points you select, the more precise the image will be drawn, but the scan time will be longer. The system default points is 201.

3.3.6.2 Parameter switch

It is used to open or close the drawing switch of the specified parameter;

3.3.6.3 Split

The split screen effect of the curve display, the split screen options provided are:

Split	Description
1-Split	All curves are displayed in the same drawing window
2-Split	4 parameters are grouped in pairs and displayed in the corresponding drawing window
4-Split	4 parameters are displayed independently in their respective drawing windows

The 2-split screen display effect is shown in Figure 3-3-4:

The 4-split screen display effect is shown in Figure 3-3-5:

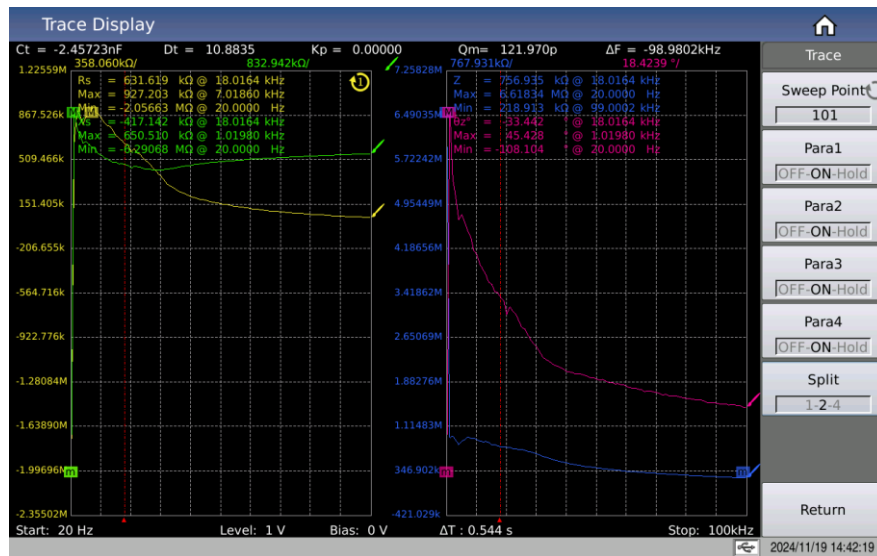

Figure 3-3-4 Display effect of 2-split screen

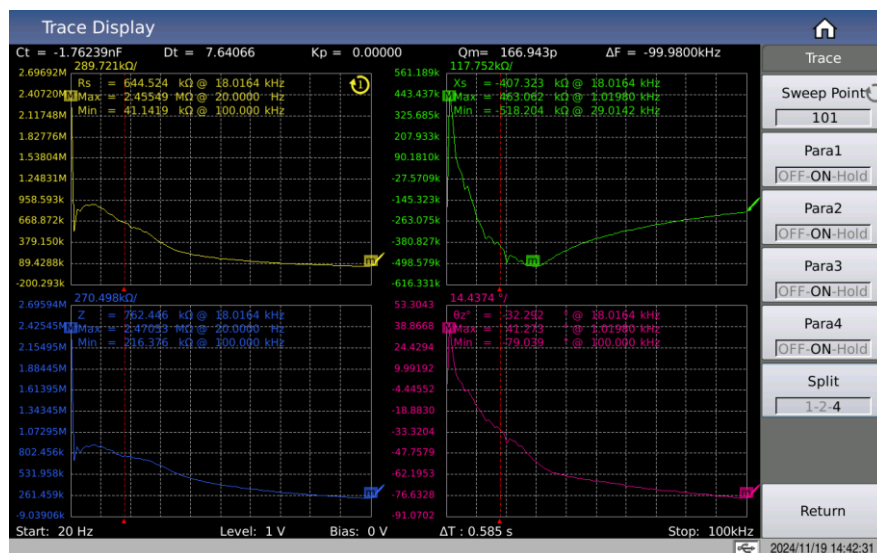

Figure 3-3-5 Display effect of 4-split screen

3.3.7 USB flash drive data save

Use the USB flash drive to save the test results. The test results and formats that can be saved are as follows:

Time,pt ,x,P1,P2,P3,P4,COMP

---Respectively correspond to test time, point index, x-axis size, parameter 1~4 result

The states involved in data preservation are:

- Save the switch;
- Save path prompt, default path location: "usb/CSV/" path;
- The naming rule of the file name is rx+machine number+date, such as:
trace-SN12345678-20210811.csv,

it is used to save the curve data to the USB flash drive, the function menu is shown in Figure 3-3-6:



Figure 3-3-6 Save setting menu

It is used to set whether to continuously save the test result data;

- In the open state of continuous saving, the naming rule of the file name is trace + machine number + date, such as: trace-SN12345678-20210811.csv,
- Single save, the naming rule of the file name is trace-trg + machine number + date, such as: trace-trg-SN12345678-20210811.csv,

3.3.8 Other test results

When the user selects the sweep parameters as frequency and impedance, the instrument will automatically display some parameters of the ultrasonic device. The specific parameters are described as follows:

Static capacitance Ct: Static capacitance value at 1kHz.

Static capacitance Dt: the capacitance loss value at 1kHz.

The minimum impedance Zmin and its corresponding frequency fs, (point m on the screen).

The maximum impedance Zmax and its corresponding frequency fp, (point M on the screen).

$$\Delta F = f_p - f_s$$

$$k_p \approx \sqrt{\frac{f_p - f_s}{f_s}} \times 2.51$$

Planar electromechanical coupling coefficient

$$Q_m \approx \frac{f_p^2}{2\pi f_s Z_{mi} C^T (f_p^2 - f_s^2)}$$

Mechanical quality factor

3.4 <Meas Setup>

Press [SETUP] to enter into the <Meas Setup> page shown as below:

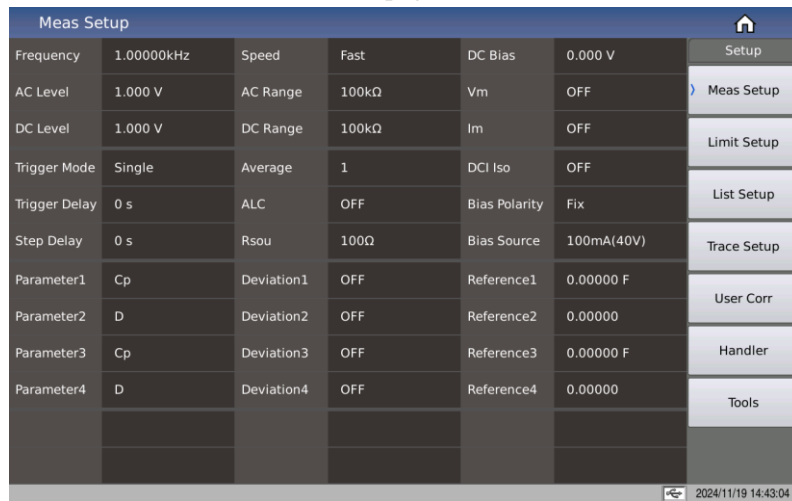

Figure 3-4-1 Measurement setting

3.4.1 Test function

Parameter setting attributes: enumerated type.

The four parameters of the impedance element can be measured at the same time in one measurement cycle. The measurable parameters are as follows:

Parameter name	Parameter meaning	Parameter name	Parameter meaning
Cp	Equivalent parallel capacitance	Cs	Equivalent series capacitance
Lp	Equivalent parallel inductance	Ls	Equivalent series inductance
Rp	Equivalent parallel resistance	Rs	Equivalent series resistance
Gp	Conductance	Bp	Susceptance
Z	Absolute value of impedance	Y	Absolute value of admittance
D	Loss factor	Q	Quality factor
θz°	Impedance degree	θz	Impedance radian

θy°	Admittance degree	θy	Admittance radian
X	Reactance	Rd	DC Resistance

Measurement function parameter setting operation steps: touch (or use the cursor keys to move the cursor to) the parameter name area corresponding to the test result, and select the setting in the soft key area on the right according to the displayed optional parameters.

There is no restriction on the combination of the four parameters, and the combination can be selected arbitrarily.

The four parameters can be set with independent display switches: that is, when the display switch corresponding to the parameter is turned off, the corresponding result area will display OFF to replace the test result display. The display switch function can be set in the parameter setting area of the measurement display page.

3.4.2 Frequency

Parameter setting attribute: numeric input.

The maximum range of the test frequency of this series is from 20 Hz to 2 MHz, and the minimum resolution is: 0.0001 Hz.

Note: The specific models have different support range for the frequency. For details, please refer to the instrument selection guide. Here is a simple comparison description:

Instrument series model	Support range of Frequency
TH2840A, TH2840AX, TH2840NX	20Hz~500kHz
TH2840B, TH2840BX	20Hz~2MHz

Frequency range and test frequency point

Frequency range (F)	Test frequency point	Resolution
20Hz ≤ F ≤ 99.999Hz	20.0000Hz, 20.0001Hz99.9999Hz	0.0001Hz
100Hz ≤ F ≤ 999.9Hz	100.000Hz, 100.001Hz999.999Hz	0.001Hz
1kHz ≤ F ≤ 9.999kHz	1.0000kHz, 1.00001kHz9.99999kHz	0.01Hz
10kHz ≤ F ≤ 99.99kHz	10.0000kHz, 10.0001kHz99.9999kHz	0.1Hz
100kHz ≤ F ≤ 999.9kHz	100.000kHz, 100.001 kHz1MHz	1Hz
1MHz ≤ F ≤ 2MHz	1.00000MHz, 1.00001 MHz2MHz	10Hz

Operation steps for setting test frequency:

Directly touch or use the arrow keys to move the cursor to the frequency domain;

There are two test frequency setting methods for single machine:

- 1) One is to use the number keys to input directly.
- 2) The other one is to use the soft key area (according to the prompts to perform frequency increase and decrease enumeration operations);

3.4.3 Level

The test level is divided into AC level and DC level;

AC level is mainly used for AC LCR test;

DC level is mainly used for DC resistance test;

3.4.3.1 AC Level

Parameter setting attribute: numeric input.

The test level is set by the effective value of the test sine wave signal. The frequency of the sine wave signal is the test frequency, which is generated by the internal oscillator of the instrument.

Either the test voltage value or the test current value can be set.

Voltage level range: 5mV ~ 20V.

Level voltage and resolution:

Voltage level (Vrms)	Resolution
[5m,1)	1mV
[1,20]	10mVrms

Current level range: 50uA ~ 100mA

Note: There is a linear constraint relationship of internal resistance between the voltage level and the current level. (For example, the current level corresponding to 30Ω internal resistance is 166.7μA ~ 66.67mA, and the current level corresponding to 100Ω internal resistance is 50μA ~ 100mA).

Note: The set test current is the output current value when the tested terminal is short-circuited. The set test voltage is the output voltage value when the test terminal is open.

Operation steps for setting test level:

Touch and click the AC level corresponding area, the menu area displays the switching function of the level type and adding smaller functions, you can modify and adjust according to the menu prompts, or you can directly enter the number keys to modify the value.

Note: When you need to switch the test level between current and voltage, you must use the menu area.

3.4.3.2 DC Level

Parameter setting attribute: numeric input.

As a test condition for DC resistance (RD).

DC level range:

Internal resistance	DC Level range
30Ω	0.1V ~ 2V

100Ω	4 parameters are all RD	0.1V ~ 20V
	Other	0.1V ~ 2V

Level voltage and resolution:

Voltage Level (Vrms)	Resolution
[0.1,1]	1mV
(1,20]	10mV

3.4.4 Speed

Parameter setting attributes: enumerated type.

The test speed is mainly determined by the following factors:

Integration time (A/D conversion);

Average times (the number of times used to obtain the average value of the continuous measurement results);

Measurement delay (the time from start to start of measurement);

Display time of measurement results;

Generally speaking, when measuring slowly, the test result is more stable and accurate.

You can choose FAST+, FAST, MED and SLOW 4 test speeds. See the description in section 8.1.9 for details.

3.4.5 Range

The range is divided into AC range and DC range. The AC range is used to test AC LCR parameters, and the DC range is used to test DC resistance.

Parameter setting attributes: enumerated type.

The test range is selected according to the impedance value of the LCR component under test.

AC test range: 0.1Ω, 1Ω, 10Ω, 20Ω, 50Ω, 100Ω, 200Ω, 500Ω, 1kΩ, 2kΩ, 5kΩ, 10kΩ, 20kΩ, 50kΩ, 100kΩ.

DC test range: 0.1Ω, 1Ω, 10Ω, 20Ω, 50Ω, 100Ω, 200Ω, 500Ω, 1kΩ, 2kΩ, 5kΩ, 10kΩ, 20kΩ, 50kΩ, 100kΩ.

Operation steps for setting test range:

Use the cursor keys to move the cursor to the Range field. The screen will display the following soft keys.

Auto

This softkey is used to set the range to AUTO (automatic) mode.

Hold

This softkey is used to switch the range from AUTO mode to HOLD mode. When the range is set to HOLD (hold) mode, the range will be locked in the current test range. The current test range will be displayed in the range field of the screen.

Increase +

This softkey is used to increase the range in the HOLD mode.

Decrease-

This softkey is used to decrease the range in HOLD mode.

Use the soft keys to set the test range.

3.4.6 DC Bias

Parameter setting attribute: numeric input.

It involves the selection of bias source and bias type, digital size range setting and other related settings.

3.4.6.1 Bias Source

This series comes standard with two types of internal bias sources or external biases for selection. The corresponding options and input ranges are as follows:

Bias Source	Bias Type	Input Range
Internal 100mA (Voltage, current, internal resistance are related to Ohm's law)	Voltage	-40V~40V
	Current	-100mA~100mA
Internal 2A	Current	0~2A
External TH1778	Current	0~120A Determined by external bias current source

3.4.6.2 Bias Type

In the case of using the internal bias source of 100mA, the bias current mode or the bias voltage mode can be selected, and the maximum setting size is restricted by the relationship of the internal resistance.

Parameter setting attribute: numeric input.

Provides a built-in DC bias voltage ranging from -40V to +40V.

Press the [DC Bias] key on the front panel to allow the set DC bias output. When the DC bias output is allowed, the [DC Bias] button will be lit.

3.4.6.3 DCI isolation

Parameter setting attributes: enumerated type.

The bias current isolation function can prevent the influence of DC current on the test input circuit. The ISO domain can set the bias current isolation function ON or OFF.

In the single measurement page (measurement display), the switch control of ISO is determined by the user's settings. In the list sweep and trace sweep test functions, when the current is above a certain level, it is automatically controlled by the set current.

Note: After the bias current isolation function is turned on, it will affect the test accuracy. Therefore,

when testing high-impedance components under low frequency and small bias current conditions, the bias current isolation function should be set to OFF.

3.4.6.4 Bias polarity

Fixed or automatic mode

3.4.7 Level monitor function

Parameter setting attributes: enumerated type.

The level monitoring function allows you to monitor the actual voltage across the DUT or the actual voltage and current values flowing through the DUT.

The voltage monitoring value is displayed in the **Vm** monitoring field on the <Meas Disp> page;

The current monitoring value is displayed in the **Im** monitoring field on the <Meas Disp> page.

Settable state: ON/OFF, respectively means to turn on/off the level monitoring function.

Note: The calibration function of the instrument has an influence on the level monitoring function. Therefore, when the correction data changes, the level monitoring value also changes. The ON/OFF status change of open circuit/short circuit/load correction function will also affect the level monitoring value.

3.4.8 Trigger

It mainly involves the trigger mode, trigger delay, and step delay settings.

Schematic diagram of trigger delay time and step delay time:

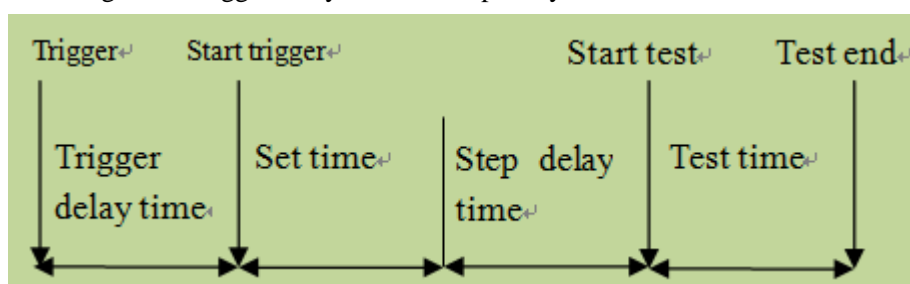

(Note: The set time in the figure is the preparation time for the signal source control of the instrument measurement, range switching, etc.)

3.4.8.1 Trigger mode

Parameter setting attributes: enumerated type.

The choice of trigger mode determines the trigger condition of the instrument test. This series provides 2 trigger modes to be set:

- 1) Continuous trigger: continuous repeat test
- 2) Single trigger: Each time you press the [Trigger] key on the front panel, and each time the HANDLER interface receives a positive pulse trigger signal or remote command, a trigger

command is given, and a test is performed.

Note: When testing, a trigger signal is received, the trigger signal will be ignored. Therefore, the trigger signal needs to be sent after the test is completed.

When you need to trigger from the optional HANDLER interface, set the trigger mode to single trigger mode.

3.4.8.2 Trigger delay

Parameter setting attribute: numeric input.

Trigger delay refers to the delay time from when the instrument is triggered to the start of measurement.

The trigger delay time setting range is: 0 s to 60 s, and the minimum resolution is 1 ms.

When the instrument is used in an automatic test system, the trigger delay function is very useful.

When the instrument is triggered by the HANDLER interface, the trigger delay time can ensure reliable contact between the DUT and the test terminal.

3.4.8.3 Step delay

Parameter setting attribute: numeric input.

The step delay is the delay time from the output of the test signal to each measurement.

The step delay time setting range is: 0 s to 60 s, and the minimum resolution is 1 ms.

Note: There are two step delays in the RD measurement, because the voltage in the positive and negative directions needs to be added, so there are two measurement cycles. So it is actually twice the step delay time.

3.4.9 Average

Parameter setting attribute: numeric input.

The average function calculates the average of the results of 2 or more tests.

The number of averages can be set from 1 to 255, and the minimum resolution is 1.

3.4.10 Automatic level control

Parameter setting attributes: enumerated type.

The automatic level control function can adjust the actual test level (the voltage at both ends of the DUT or the current flowing through the DUT) to the set test level value as much as possible. Using this function can ensure that the test voltage or current at both ends of the DUT remains constant.

Note: When the constant level function is valid, if the level setting exceeds the above range, the constant level function will be automatically set to OFF. The currently set level value is generally regarded as a non-constant level value.

The constant level function is set to ON or OFF, indicating that the automatic level control function is turned on or off respectively. The automatic level control function can realize constant voltage or current measurement. When the automatic level control function is turned on, a "*" sign will be

displayed after the current level value.

3.4.11 Source resistance

When using the internal 100mA bias current, the output of the signal source has an output resistance, and the output signals of other bias current modes are not output through this internal resistance. Parameter setting attributes: enumerated type.

The internal resistance can be selected: 100 Ω , 30 Ω , and the default is 100 Ω .

When testing inductance, in order to compare data with other types of testers, it is necessary to ensure the same output resistance value.

Note: When using the **internal 100mA** bias current output, 100 Ω internal resistance is recommended by default.

3.4.12 Deviation and reference

3.4.12.1 Deviation mode

Parameter setting attributes: enumerated type.

The deviation test function can make the deviation value (instead of real test value) be directly displayed on the screen. The deviation value is equivalent to the real test value subtracting the pre-set reference value. This function brings great convenience to observe variations of component parameters with temperature, frequency, bias.

The instrument provides two deviation test modes as below:

■ Δ (Absolute Deviation mode)

The deviation currently displayed is the difference between the test value of the DUT and the preset reference value. The formula of calculating Δ ABS is as below:

$$\Delta = X - Y$$

Where, X is the test value of DUT

Y is the preset reference value.

■ $\Delta\%$ (Percentage deviation mode)

The deviation currently displayed is the percentage of the difference between the test value of DUT and the preset reference value divided by the reference value. Its calculating formula is as below:

$$\Delta\% = (X - Y) / Y \times 100 [\%]$$

Where, X is the test value of DUT.

Y is the preset reference value.

If the reference value is 0, the test result shows Inf;

3.4.12.2 Deviation reference value

Parameter setting attribute: numeric input type.

It is the reference value used to calculate the deviation of the test result;

Reference value setting method:

- 1) Regular numerical input;
- 2) Automatic recording after measurement: Select the measurement function in the corresponding menu area of the reference, a test will be executed, and the test result will be recorded here as the parameter value.

3.5 <Limit Setup>

Press the menu key [Setup], and then press the Limit Setup soft key to enter the <Limit Setup> page. As shown in Figure 3-5-1:

Limit Setup							Setup
Comp	OFF	Para	Cp	D	Cp	D	Meas Setup
Count	OFF	Dev	OFF	OFF	OFF	OFF	Limit Setup
Mode	Tol	Ref	0.00000 F	0.00000	0.00000 F	0.00000	List Setup
BIN1	OFF	Low	-----	-----	-----	-----	Trace Setup
		High	-----	-----	-----	-----	User Corr
BIN2	OFF	Low	-----	-----	-----	-----	Handler
		High	-----	-----	-----	-----	Tools
BIN3	OFF	Low	-----	-----	-----	-----	
		High	-----	-----	-----	-----	
BIN4	OFF	Low	-----	-----	-----	-----	
		High	-----	-----	-----	-----	
BIN5	OFF	Low	-----	-----	-----	-----	
		High	-----	-----	-----	-----	
BIN6	OFF	Low	-----	-----	-----	-----	
		High	-----	-----	-----	-----	
BIN7	OFF	Low	-----	-----	-----	-----	
		High	-----	-----	-----	-----	
BIN8	OFF	Low	-----	-----	-----	-----	
		High	-----	-----	-----	-----	
BIN9	OFF	Low	-----	-----	-----	-----	
		High	-----	-----	-----	-----	
BIN10	OFF	Low	-----	-----	-----	-----	
		High	-----	-----	-----	-----	

Figure 3-5-1 Limit setup

The comparator function of the instrument can be set on this page.

10 bin limits can be set, and the measured results can be sorted into up to 11 bins (BIN1 to BIN10 and BIN OUT).

Comparison ON/OFF (comparison function switch)

Count ON/OFF (comparison count switch)

Mode (comparison function limit mode)

Parameters (test parameters)

Deviation (deviation mode)

Reference (reference value in deviation mode, namely nominal value)

Switches for each sorting bin

Lower limit value of each BIN (Low)

Upper limit value of each BIN (High)

3.5.1 Compare switch

Parameter setting attributes: enumerated type.

Setting item	Meaning description
--------------	---------------------

OFF	Turn off the compare function
ON	Turn on the compare function

3.5.2 Compare count switch

Parameter setting attributes: enumerated type.

Setting item	Meaning description
OFF	Turn off the compare count function
ON	Turn on the compare count function

3.5.3 Comparison function limit mode

The comparison function provides the following two parameter limit setting modes. As shown in Figure 3-3.

1) Tolerance mode

In tolerance mode, set the deviation value from the nominal value (the nominal value is set in the nominal field) as the comparison limit value. There are two ways of deviation: one is the percentage deviation, and the other is the absolute deviation.

2) Sequential mode

In sequential mode, the test value range is used as the comparison limit value. The comparison limit value must be set in ascending order.

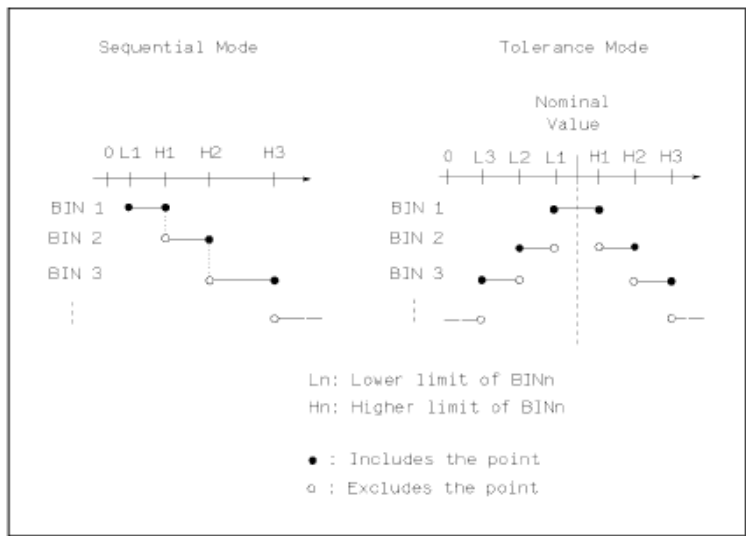

Figure 3-5-2 Tolerance mode and continuous mode

Note: When setting the limit value of the tolerance mode, the error range must be set from small to large. If the error range set by BIN1 is the largest, then all the tested parts will be sorted into BIN1 file.

In tolerance mode, the lower limit does not have to be less than the nominal value, and the upper limit does not have to be greater than the nominal value. The limits of each BIN can be discontinuous or overlapped.

3.5.4 Compare parameters

The comparison parameters adopt the 4 measurement parameters, which are consistent with the 4 measurement parameters; the sorting parameters can be modified on the measurement display page or the measurement setting page.

3.5.5 Deviations and references

Refer to the setting of the deviation and reference on the measurement setting page, the meaning of the parameter here is exactly the same as the meaning of the measurement setting.

3.5.6 BIN Switch

Parameter setting attributes: enumerated type.

Set the independent comparison switch of the specific sorting BIN:

Setting Item	Meaning description
OFF	Turn off the comparison function of the specified BIN
ON	Turn on the comparison function of the specified BIN

When the corresponding sorting BIN is OFF, the sorting process will skip this sorting limit comparison.

3.5.7 High-low limit

As the main basis for parameter comparison.

If the upper and lower limits of the corresponding BIN are not set, it indicates that the parameter in the corresponding BIN does not participate in the comparison, that is, the test result does not affect the comparison result; if only a lower limit or upper limit is set, the effect of unilateral comparison will be produced.

Parameter setting attribute: numeric input type.

Note: When the upper and lower limits only set the upper or lower limit, it is regarded as a unilateral comparison.

3.6 <List Setup>

Press [SETUP] and then **List Setup** to enter into the <List Setup> page as shown below.

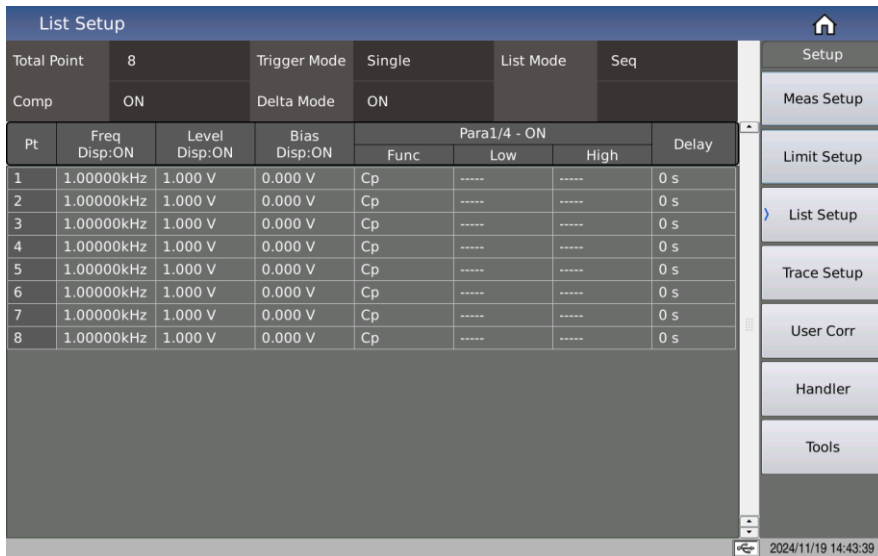

(Figure 3-6-1 List setup)

The list sweep function can perform auto sweep test for the test frequency, test level or bias voltage of 201 points. On <LIST SETUP> page, the following list sweep parameters can be set.

- Total Point
- Trigger mode
- List mode (sweep mode)
- Comparison (Comparator)
- Difference Mode
- Sweep condition (frequency [**H**z], level [**V**], level [**I**], bias [**V**], bias [**I**])
- Parameter function
- High/low limit (**HIGH**, **LOW**)
- Single point delay (**DELAY**[s])

3.6.1 Total Point

Set the number of points to be scanned for list sweep, the value range is 1~201;
Parameter setting attributes: enumerated type.

3.6.2 Trigger mode

It is the same as the trigger mode on the measurement setting page.

After the list sweep is triggered normally, the user can interrupt the list sweep process by pressing the Reset button:

Press Reset once to enter the pause state, and continue scanning at the current point after triggering again;

Press Reset twice to enter the reset state, and sweep from the first point after triggering again;

3.6.3 List mode

Set list sweep mode, sequence mode or single-step mode.

Parameter setting attributes: enumerated type.

Sequence mode	When the trigger is valid, sweep sequentially from the first point to the last point
Single-step mode	When the trigger is valid, only one point can be tested at a time

Note: The effect of the list mode is mainly reflected in the single trigger mode. If it is the continuous trigger mode, the test process of the two modes will be visually different.

3.6.4 Difference Mode

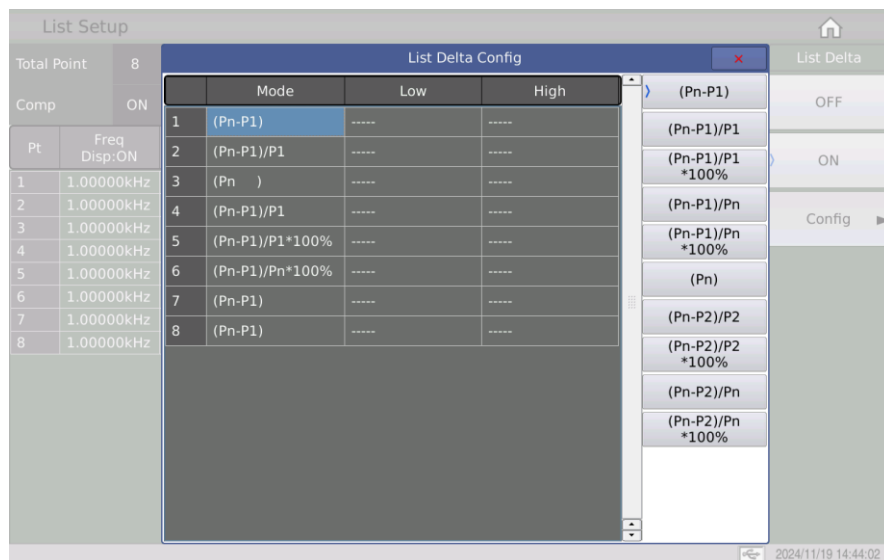

(Image 3-6-2 Difference Mode Configuration)

In the list sweep of parameter 1, the sweep point n (n range 1~201) is compared with the parameter 1 reading of sweep point 1 or sweep point 2 by difference.

When the difference mode is not enabled and the comparison switch in section 3.6.8 is enabled, the list display page is as shown in Figure 3-2-1 in section 3.2, and the pass/fail result output is based on the upper and lower limit comparison results of the measured data of parameters 1 to 4.

When the comparison switch in Section 3.6.8 is turned on and the difference mode is turned on, the list display page is as shown in Figure 3-2-2 in Section 3.2 and the difference calculation result is displayed at the same time. The pass/fail result is output based on the comparison result of the difference calculation result.

3.6.5 Sweep condition

Frequency, level, and bias can be set independently, and can also be quickly set to make one of the conditions remaining relatively regular.

If you are only concerned about the impact of one condition change on the DUT, you can quickly set

other test conditions to the same result, such as a linear change in frequency, and a fixed level and bias.

Regarding the frequency, level and bias in the sweep condition, you can choose whether to display it on the test page, touch the title area corresponding to the parameter, and then select ON or OFF on the corresponding menu.

3.6.6 Parameter function

4 parameter functions, all of which can be set independently, and can also be quickly set to make one of the conditions relatively consistent;

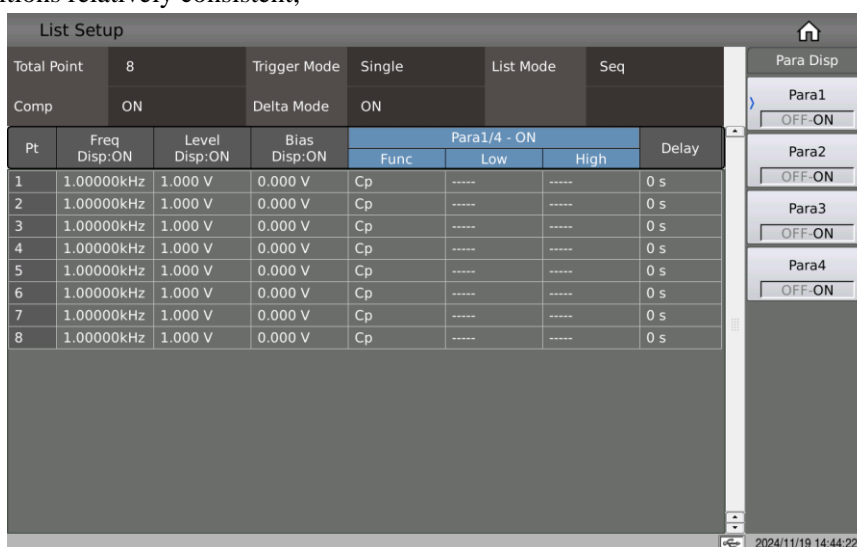

Figure 3-6-3 List parameter display menu

3.6.7 High/low limit

The upper and lower limits of the parameters can be set independently, and can also be set quickly to make the settings have a certain relationship.

3.6.8 Comparison

The upper and lower limits of the parameters are used as the main basis for comparing the parameters. When differential mode is enabled, the P/F result is displayed by comparing the upper and lower limits of the difference of Parameter 1. Parameter 2 is used only to display the measurement result and does not participate in the comparison.

Parameter setting attributes: Enumeration type.

Setting item	Meaning Description
OFF	Comparison function is off
ON	Comparison function is turned on

3.6.9 Delay

The delay parameter indicates the delay time from the completion of each sweep step measurement to the next sweep measurement. It is mainly used to connect an external bias source (such as TH1778) to adapt to the delay time setting required by the external bias current source. (Note: The delay here can be accumulated with the delay in the measurement setting interface.)

3.7 Trace Setup

Press [Setup] and then **Trace Setup** to enter into the <Trace Setup> page as the following figure shown.

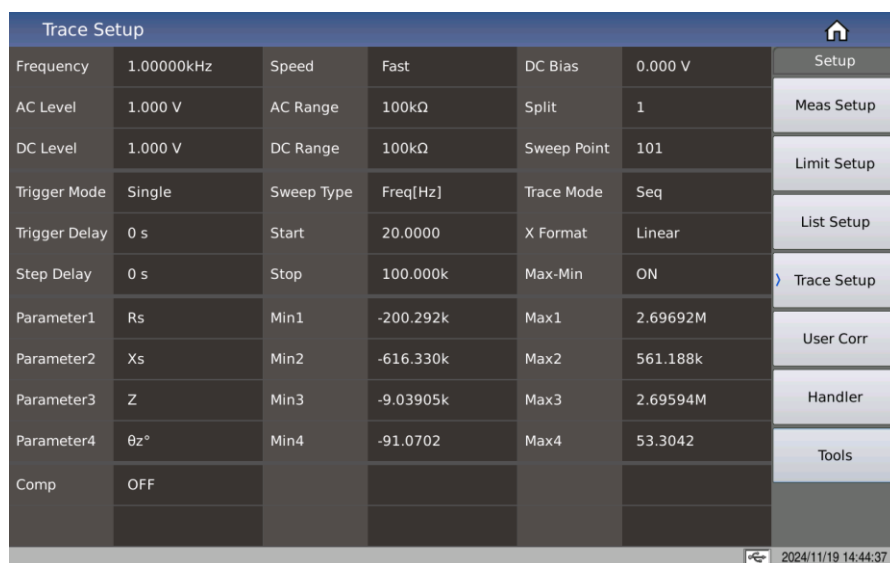

Trace Setup						Setup
Frequency	1.0000kHz	Speed	Fast	DC Bias	0.000 V	Meas Setup
AC Level	1.000 V	AC Range	100kΩ	Split	1	Limit Setup
DC Level	1.000 V	DC Range	100kΩ	Sweep Point	101	List Setup
Trigger Mode	Single	Sweep Type	Freq[Hz]	Trace Mode	Seq	Trace Setup
Trigger Delay	0 s	Start	20.0000	X Format	Linear	User Corr
Step Delay	0 s	Stop	100.000k	Max-Min	ON	Handler
Parameter1	Rs	Min1	-200.292k	Max1	2.69692M	Tools
Parameter2	Xs	Min2	-616.330k	Max2	561.188k	
Parameter3	Z	Min3	-9.03905k	Max3	2.69594M	
Parameter4	θz°	Min4	-91.0702	Max4	53.3042	
Comp	OFF					

Figure 3-7-1 Trace Setup

This display function page is used to complete the setting of trace sweep measurement parameters, including split, sweep point, sweep type, start condition, stop condition, trace mode, X Format, Max-Min switch, 4 parameters, and Y display range, etc.

3.7.1 Common test conditions

Frequency, level, speed, range, offset, trigger, delay, etc. are all common test conditions, and their meaning and setting method are exactly the same as the description on the measurement setting page.

3.7.2 4 sweep parameters

The 4 sweep parameters are used to specify the result parameters of the trace sweep, that is, to draw the test results under certain conditions into a curve;

The 4 sweep parameters and the conventional component 4 test parameters are independent of each

other and not directly related. Optional parameters can be selected except RD;
 The 4 sweep parameters correspond to 4 curves, each curve has independent display switch, display scale and independent ordinate scale, but share the same abscissa scale.

3.7.3 Spilt

For the curve display effect, 3 kinds of split screen display are available:

Split	Description
1 Split	All curves are displayed in the same drawing window
2 Split	4 parameters are grouped in pairs and displayed in the corresponding drawing window
4 Split	4 parameters are displayed independently in their respective drawing windows

3.7.4 Sweep point

Here is the number of points to be scanned. There are five groups of 51, 101, 201, 401, 801 to choose from.

3.7.5 Sweep Type

The sweep type is mainly used to set the conditions of the trace sweep, that is, to plot the test results according to the selected condition parameters, so it involves the type of condition parameters, the start size and the stop size of the condition change.

Sweep Type

Set the main conditions corresponding to the sweep curve, namely frequency [Hz], level [V], level [A], bias [V], bias [A];

Sweep type	Description	Linear	Logarithm
Freq[Hz]	The condition changes within the specified interval (between start and stop), and record the corresponding parameter results after changing in a linear or logarithmic relationship	√	√
Level [V]		√	×
Level[A]		√	×
Bias[V]		√	×
Bias[A]		√	×

Starting conditions

After selecting the sweep type, to set the start size and stop size of the corresponding conditions; that is, the start and stop points of the trace sweep.

3.7.6 Trace mode

Set the trace sweep mode, sequence mode or single step mode.

Parameter setting attributes: enumerated type.

Sequence mode	When the trigger is valid, sweep sequentially from the first point to the last point
Single step mode	When the trigger is valid, only one point can be tested at a time

Note: The effect of the trace mode is mainly reflected in the single trigger mode. If it is the continuous trigger mode, the test process of the two modes will be visually different.

3.7.7 X Format

This area is used to change the coordinate mode of sweep, mainly for the abscissa. (Note: Only the log mode is valid for the sweep frequency.)

Linear	The sweep condition parameters are linearly distributed in the start and stop ranges
Logarithm	The sweep condition parameters are distributed in a logarithmic manner with the base 10 in the start and stop ranges

3.7.8 Max-Min

Set ON or OFF:

ON	Display the maximum and minimum values of the parameter curve results
OFF	Do not display the maximum and minimum values of the parameter curve results

3.7.9 Curve Comparison Configuration

Provides a comparison function for curve data that includes a range comparison of the entire parameter, a comparison of the minimum and maximum values of the specified curve, a comparison of the abscissa corresponding to the minimum and maximum values, and a comparison of the relevant piezoelectric test parameters;

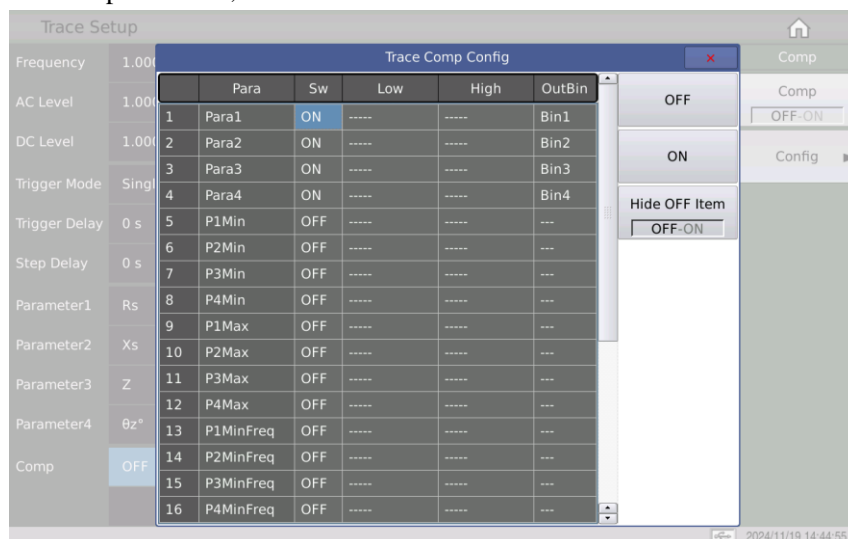

Figure 3-7-2 Trace comparison Configuration

3.8 User Correction

10 user **Pt** are provided on the <User Corr> page. In the **Freq** domain, you can set whether the calibration data of the corresponding point is turned on. After turning on, manually enter the frequency corresponding to the calibration, and then use the soft key **Open** to execute open correction, short correction, and load correction for the set frequency.

Press the menu key [Setup], and press the soft key User Corr to enter the <User Corr> page.

As shown in Figure 3-8-1:

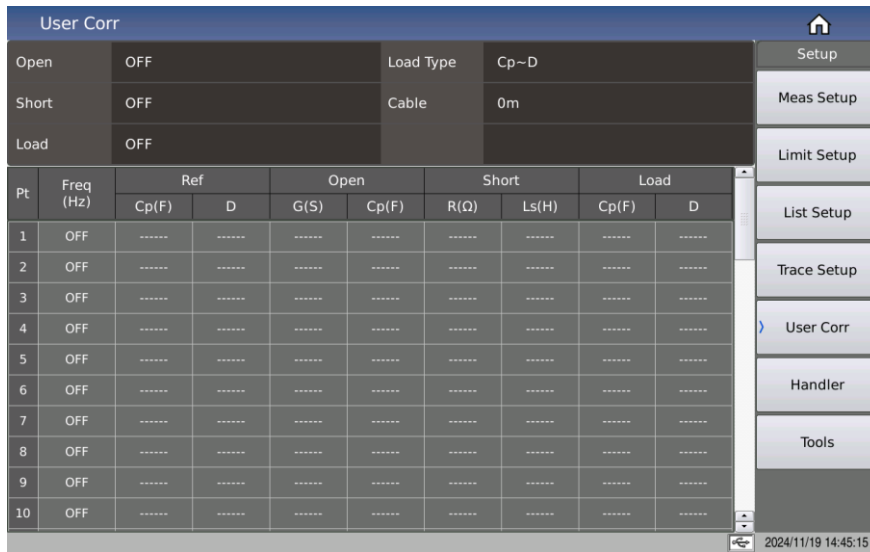

Figure 3-8-1 User correction

The open, short and load correction functions on the <User Corr> page can be used to eliminate distributed capacitance, parasitic impedance and other measurement errors.

Two correction methods are provided:

Correction mode	Description
Full frequency correction	Use insertion method to execute open and short correction of all frequency points
Point frequency correction	Execute open, short and load correction of the current set frequency point

The following measurement control parameter setting domains can be set on the <User Corr> page. Open circuit correction (Open), short circuit correction (Short), load correction (Load), cable length selection (Cable), Load type, point frequency correction switch, reference value, etc.

3.8.1 Open

The open correction function can eliminate the error caused by the stray admittance (G, B) connected in parallel with the component under test. As shown in Figure 3-8-2.

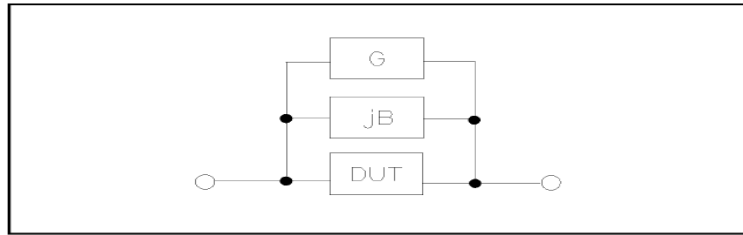

Figure 3-8-2 Stray admittance

The following two open-circuit correction data are used:

Regardless of the frequency you currently set, perform an open-circuit correction test on all the following fixed frequency points. In addition to the following frequency points, based on the open-circuit correction data at the following frequency points, the instrument can calculate all open correction data of different test ranges which corresponds to all test frequencies by using the interpolation calculation method. Move the cursor to the **Open** field, and use the softkey **Meas Open** to execute the full frequency open correction. The fixed frequency points are as follows (some models will be limited due to different frequency ranges).

20 Hz	25 Hz	30 Hz	40 Hz	50 Hz
60 Hz	80 Hz	100 Hz	120 Hz	150 Hz
200 Hz	250 Hz	300 Hz	400 Hz	500 Hz
600 Hz	800 Hz	1 kHz	1.2 kHz	1.5 kHz
2 kHz	2.5 kHz	3 kHz	4 kHz	5 kHz
6 kHz	8 kHz	10 kHz	12 kHz	15 kHz
20 kHz	25 kHz	30 kHz	40 kHz	50 kHz
60 kHz	80 kHz	100 kHz	120 kHz	150 kHz
200 kHz	250 kHz	300 kHz	400 kHz	500 kHz
600 kHz	800 kHz	1MHz	1.1MHz	1.2MHz
1.3MHz	1.4MHz	1.5MHz	1.6MHz	1.7MHz
1.8MHz	1.9MHz	2MHz		

Operation steps of open correction function:

Open correction includes full frequency open correction using interpolation calculation method and single frequency open correction for the set frequency point. Carry out the following steps to perform open correction for full frequency using the insertion calculation method. For details about single-frequency open correction, please refer to the "Load Correction" operating instructions.

Move the cursor to the **Open** setting field, and the following soft keys are displayed in the soft key area of the screen.

Function	Description
OFF	Turn off the open correction function. The calculation of open correction will no longer be carried out in the subsequent measurement process.
ON	Make the open correction valid and the open correction calculation will be performed in the subsequent test process. If the frequency settings are all OFF, the open correction calculation uses the open correction data of the current frequency calculated by the interpolation method. If the

	frequency is set to ON, and the current test frequency is equal to the corresponding frequency, the open correction data of the corresponding frequency will be used for the calculation of open correction.
Meas Open	The open admittance (capacitance and inductance) at the above fixed frequency point will be measured. It takes about 75 seconds for open-circuit full-frequency correction. During open-circuit full-frequency correction, the following soft keys are displayed.
DCR Open	The open circuit resistance measurement under the DC resistance function will be performed.
Note: Connect the test fixture to the test terminal of the instrument. The fixture is open and not connected to any component under test.	

3.8.2 Short

The short correction function of TH2840 can eliminate the error caused by spurious inductance (R, X) in serial with DUT as shown in figure 3-8-3.

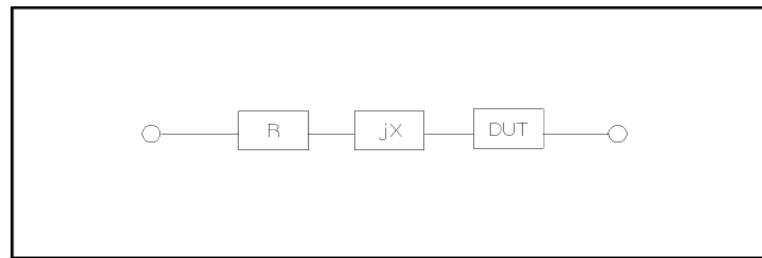

Figure 3-8-3 Spurious Inductance

The following two short-circuit correction data are used:

Regardless of the frequency you currently set, perform an short-circuit correction test on all the following fixed frequency points. In addition to the following frequency points, based on the short-circuit correction data at the following frequency points, the instrument can calculate all short correction data of different test ranges which corresponds to all test frequencies by using the interpolation calculation method. Move the cursor to the Short field, and use the softkey MEAS Short to execute the full frequency short correction. The fixed frequency point is the same as the open correction.

Operation steps of short-circuit correction function:

The short-circuit correction includes the full-frequency short-circuit correction using the insertion calculation method and the single-frequency short-circuit correction for the set frequency point. Perform the following steps to perform short-circuit correction at full frequency using the insertion calculation method. For details on single-frequency short-circuit correction, please refer to the "Load Correction" operating instructions.

Move the cursor to the short-circuit setting field, and the following soft keys are displayed in the soft key area of the screen.

Function	Description
OFF	Turn off the short correction function. The

	calculation of short correction will no longer be performed in the subsequent measurement process.
ON	Make the short correction valid and the short correction calculation will be performed in the subsequent test process. If the frequency settings are all OFF, the open correction calculation uses the short correction data of the current frequency calculated by the interpolation method. If the frequency is set to ON, and the current test frequency is equal to the corresponding frequency, the short correction data of the corresponding frequency will be used for the calculation of short correction.
Meas Short	Connect the test fixture to the test terminal of the instrument. Short the test fixture with a short-circuit strip. Press the soft key Meas short , and the short-circuit parasitic impedance (resistance and reactance) at the above fixed frequency point will be measured. It takes about 75 seconds for the short-circuit full-frequency correction. During the short-circuit full-frequency correction process, the following soft keys are displayed on the screen.
DCR Short	The short-circuit resistance measurement of the DC resistance function will be performed.

3.8.3 Load

The load correction function uses the transfer coefficient between the actual test value at the set frequency point and the standard reference value to eliminate other test errors. It can be seen that open circuit, short circuit and load correction can be performed at the set frequency point. Before setting the standard reference value, the reference value must be set in the reference value corresponding field. When the cursor moves to Freq or Ref, the screen displays the soft key **Load**. Press the **Load** key to perform a load correction test on the standard.

Load correction function switch option:

Function	Description
OFF	Invalidate the load calibration test data under the current set frequency.
ON	Make the load calibration test data valid at the current set frequency.

3.8.4 Load type

When performing load correction, the reference value of the standard device must be input in

advance.

The test parameters of the reference value should be consistent with the set load correction test function. The load correction function uses the transfer coefficient between the actual test value at the set frequency point and the standard reference value to eliminate other test errors. The load correction test function is only used to calculate the transfer coefficient.

This series categorizes the load types into 3 categories:

Load Type	Description
Ls~Rs	
Ls~Q	
Cp~D	

3.8.5 Cable

The cable length currently available is 0 m and 1 m.

The factory default is 0m calibration.

3.8.6 Point frequency operation

Follow the steps below to perform an open/short/load correction test on the set frequency point.

























Move the cursor to the frequency setting area. The screen will display the following soft keys.

Function	Description
OFF	Invalidate the open/short/load calibration test data at the current set frequency.
ON	Make the open/short/load correction test data valid under the current set frequency, and the frequency setting field displays the originally set open/short/load correction frequency.
Open	Perform a open correction test on the current frequency
Short	Perform a short correction test on the current frequency.
Load	Perform a load correction test on the current frequency.

3.8.6.1 Steps of load correction

1. Move the cursor to the **Freq** setting area, and set the frequency to be calibrated.
2. Open the test fixture, and press the soft key **Open** to perform open correction for the current set frequency.
3. Short-circuit the test fixture and press the soft key **Short** to perform short-circuit correction for the current set frequency.
4. Prepare a measurement standard device, move the cursor to the **Load Type** setting field, and set the type of function parameters that the standard device needs to measure.
5. Move the cursor to the corresponding frequency setting domain, connect the standard device to the test fixture, press the softkey **Load**, and the instrument will perform a load calibration. The actual test result of the standard device is displayed on the load.

3.9 Handler Settings

LCR Handler								Function
User define								
Pin	Signal	Direction	Function	Pin	Signal	Direction	Function	
1	BIN1	Output		14,15	ExtDCV2	Input	3.3V ~ 24V	OFF
2	BIN2	Output		16,17,18	+5V	Output	I _{max} < 0.3A	OFF
3	BIN3	Output		19	Pass	Output		
4	BIN4	Output		20	Fail	Output		
5	BIN5	Output		25	Lock	Input		
6	BIN6	Output		27,28	ExtDCV1	Input	3.3V ~ 24V	
7	BIN7	Output		29	Alarm	Output		
8	BIN8	Output		30	Index	Output		
9	BIN9	Output		31	Eom	Output		
10	BIN10	Output		34,35,36	Com1	Input	GND1	
12,13	ExtTrig	Input		32,33	Com2	Input	GND2	
11,21,22 23,24,26	Reserve							

(Figure 3-9-1 Handler Settings)

The input and output I/O interfaces are active low by default, and the trigger mode can be changed as needed.

For details on the handler interface, refer to Chapter 10 Handler Interface Description.

Chapter 4 System and File

4.1 <System Setup>

Press the menu key [System] to enter the <System Setup> page. As shown in Figure 4-1-1:

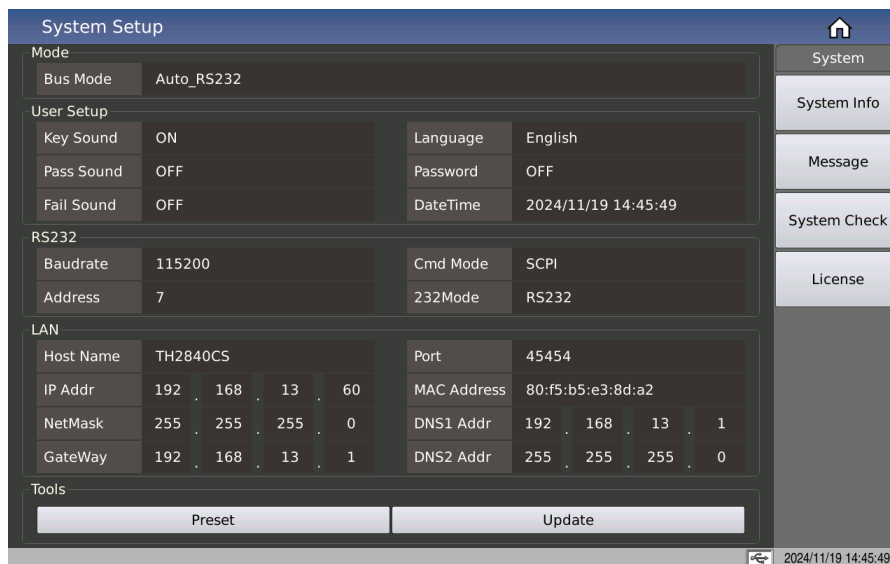

Figure 4-1-1 System Setup

4.1.1 Mode Setup

4.1.1.1 Bus Mode

The bus mode is used to select the communication mode of the instrument.

The options are as follows:

AUTO	Automatically select the RS232/LAN/USB communication mode according to the external signal input
RS232	RS232
	External 485
	External GPIB
LAN	
USB Device	USBCDC
	USBTMC

Note: The GPIB option of our company must be installed to support the GPIB mode.

When using the RS485 or GPIB interface, the bus address under the RS232 setting will be used as the local address.

4.1.2 User Setup

4.1.2.1 Key Sound

Parameter type: enumerated

Parameter option	Description
OFF	Turn off the key sound.
ON	Turn on the key sound.

4.1.2.2 Pass Sound

Parameter type: enumerated

Parameter function: This area is used to control and display the sound mode when the measurement comparison result of the instrument is qualified.

Parameter option	Description
OFF	Choose not to sound the alarm
Two short	Choose to emit two low and short alarm sounds
Low long	Choose to emit a low and long alarm sound
High short	Choose to emit a high and short alarm sound
High long	Choose to emit a high and long alarm sound

4.1.2.3 Fail Sound

Parameter type: enumerated

Parameter function: This area is used to control and display the alarm sound mode when the measurement comparison result of the instrument is defective.

Parameter option	Description
OFF	Choose not to sound the alarm
Two short	Choose to emit two low and short alarm sounds
Low long	Choose to emit a low and long alarm sound
High short	Choose to emit a high and short alarm sound
High long	Choose to emit a high and long alarm sound

4.1.2.4 Language

Parameter type: enumerated

Parameter function: This area is used to control and display the operating language mode of the current instrument.

Parameter option	Description
------------------	-------------

English	Choose English operating language
Chinese	Choose Chinese operating language

4.1.2.5 Password

Parameter type: enumerated type + input type

Parameter function: This area shows the current password protection mode.

Parameter operation options	Description
OFF	Turn off the password protection
Lock system	Open the password protection, including file protection and power-on password
Lock file	File protection for users
Lock setup	Used to restrict the tester's modification operations on the setting file
Modify	This soft key is used to modify the password. Modify operation: after pressing this button, enter the new password according to the prompt on the screen. After inputting from the keyboard, the screen prompts to confirm the new password, repeat the new password, and the password modification is completed.

Note: The factory default password is 2840.

4.1.2.6 Datetime

When moving to the datetime zone, you can modify the system time.

4.1.3 RS232

The general setting parameters of the serial port are: 8 data bits, 1 stop bit, no parity bit.

4.1.3.1 Baudrate

Parameter type: enumerated

Parameter function: used to select the baud rate of the built-in RS232 interface of the instrument.

Options	
4800	9600
19200	38400
57600	115200

4.1.3.2 Address

Parameter type: input type

Parameter function: used to control and display the RS485, GPIB interface and Modbus bus address of the current instrument.

Value range: 1~32

4.1.3.3 Cmd mode

Parameter type: enumerated

Parameter function: command mode can be set with SCPI command and ModeBus command protocol.

Parameter option	Description
SCPI	Adopt general ascii string command protocol
ModBus	Adopt ModBus command protocol

For related introduction, please refer to Chapter 11 Communication Command Reference Chapter.

4.1.4 LAN

Configure the corresponding address parameters according to the specific attributes of the connected LAN, and plug in the network cable on the rear panel to use the network port for communication.

If you need to modify the relevant address parameters, you can directly double-click the corresponding address display window to pop up the numeric keyboard, enter the correct network configuration on the numeric keyboard, and click OK to exit the keyboard to complete the modification;

If the connected networking equipment (router or switch) supports the automatic IP allocation function, you can directly click the automatic configuration button in the display window to try the automatic configuration. The configuration takes a few seconds. Do not operate the machine during the configuration process; if it does not support it You need to manually assign the setting address; if the automatic configuration fails, you may get the loopback IP address of the machine, that is, 127.0.0.1; at this time, you can click the default setting button in the display window to restore the default configuration, and then start again on the basis of the default configuration. Just make fine adjustments, and you can consult the company's network technical engineer to obtain the address parameters of the network configuration.

Default port number: 45454

The host name generally corresponds to the instrument model.

4.1.5 Tools

4.1.5.1 Preset

For the convenience of customers, the instrument can be initialized to a known unified initial state. Standardize initial software operation design .

In order to solve the problem of inconsistent setting status when the instrument leaves the factory.

	English menu	Description	Command
1	CLEAR SETTING	Restore the following parameters to the factory default settings: a. Parameters set through front panel operation b. Parameters set by SCPI commands	*RST
2	CLEAR SET&CORR	Restore the following parameters to the factory default settings: a. Parameters set through front panel operation b. Parameters set by SCPI commands c. Power-off protection parameters d. Clear user correction data	:SYST:PRES
3	FACTORY DEFAULT	Restore the following parameters to the factory default settings: a. Parameters set through front panel operation b. Parameters set by SCPI commands c. Power-down protection data d. Clear user reset data e. Clear files saved by users	:SYS:DEFT

Note: Parameters that cannot be initialized

The initialization operation is not allowed to clear the system calibration data.

The real-time clock date and time are not allowed to be cleared or initialized.

Please refer to the appendix for the detailed recovery list of parameters later.

4.1.5.2 Update

This function is mainly used for software version upgrade and maintenance. This series of machines is designed with multiple CPUs, and a one-key upgrade operation is provided for user convenience. After performing the one-key upgrade, the user only needs to follow the prompts and wait for about 15 seconds. After the upgrade is completed, the instrument will reboot automatically, and after the reboot, you can return to this menu to check whether the software version is the latest version after the upgrade.

The instrument provides several ways to upgrade for the convenience of the users, including performing the upgrade directly on the specified file in the file system management list;

or using the default upgrade path, that is, performing the upgrade by running the "usb/update2840.sec" file. That is, place the update2840.sec upgrade file in the root directory of the USB flash drive, and the operation menu will send instructions to the device to perform the

one-click upgrade operation; it can also be used in conjunction with our own PC tool to upgrade the specified file on the PC;

The menu display is shown in Figure 4-1-2:

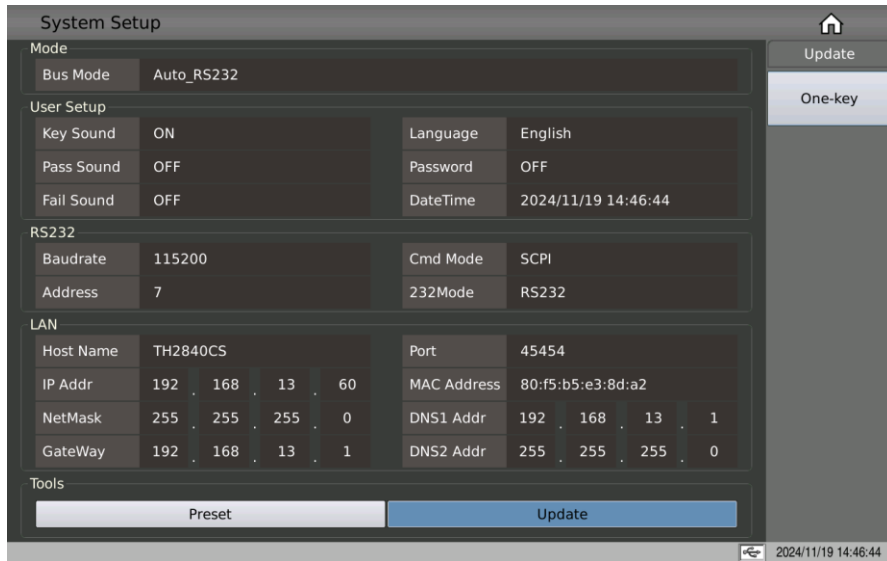

Figure 4-1-2 Upgrade menu

The dynamic prompt window of one-click upgrade is shown in Figure 4-1-3:

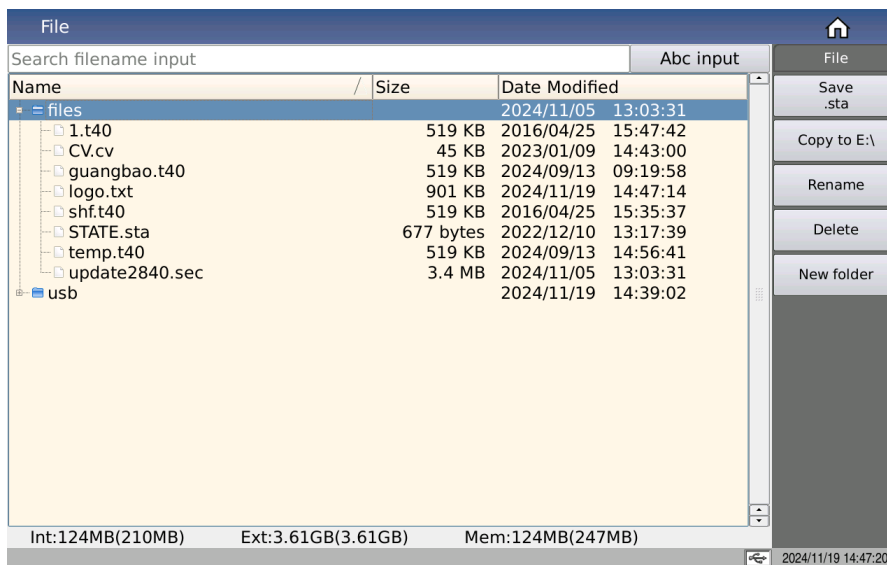
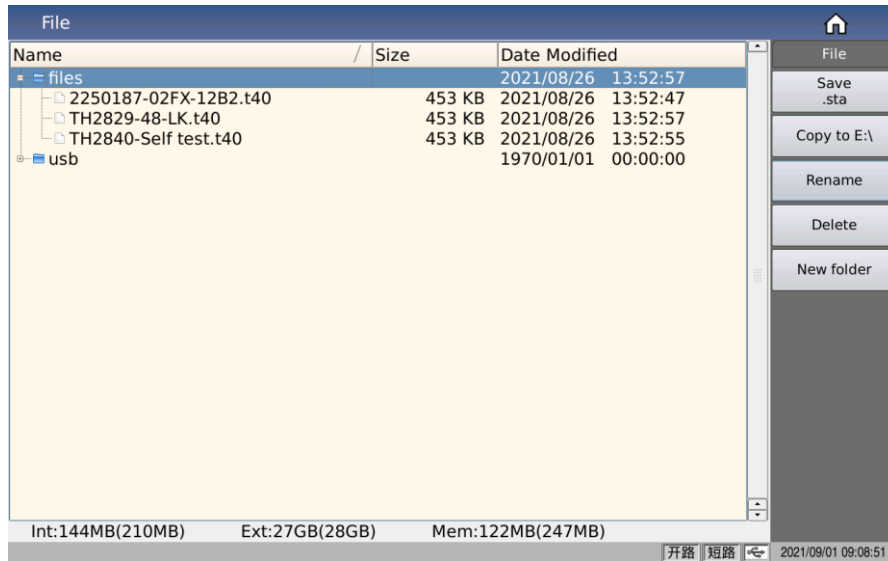

Figure 4-1-3 Upgrade waiting prompt

4.2 <File>

Because this series is equipped with an embedded system, it is very convenient to store the parameters set by the user in the form of a file in the system internal or external U disk. When the same settings are to be used next time, the user does not need to reset these parameters, Just load the corresponding file, you can get the last set parameters. This greatly saves the user's time to repeatedly set parameters and improves production efficiency.

Press the soft key [File] to enter the <File> function page. As shown in Figure 4-2-1:



4.2.1 U-disk manage performance

As mentioned above, this series is equipped with a USB HOST interface as standard, and an external USB flash drive can be used as a storage medium, thus breaking the limitation of the internal storage size of the instrument. You can also copy these files to an IBM PC with a USB interface or a desktop computer or Notebook computers compatible with it, so as to achieve unlimited expansion.

Supports USB storage devices (USB flash drives) with the following performance:

Compliant with USB 2.0 standard

File format: FAT16 or FAT32 (formatted with Microsoft Windows operating system)

4.2.2 Introduction to Store/Recall Function

This section will introduce information about the store/recall function. Through the storage/recall function, the user can save the instrument configuration information to the internal Flash of the instrument or an external USB flash drive, and recall it from the internal Flash or external USB flash drive of the instrument. The test results and screenshots can only be saved in the external USB flash drive.

Symbol Description:

- files: internal files;
- usb: external file

The storage methods and uses are introduced. The following table 4-1 explains the available storage methods and their uses:

Store method		Can be recalled or not	Usage
Type	file format		
LCR Setting files	*.sta	Yes	Save the LCR test configuration status of

			the instrument
Transformer single group setting file	*.trt	Yes	Save the instrument's transformer single-group test configuration status
Transformer sweep setting file	*.t40	Yes	Save the instrument's transformer sweep test configuration status
Screenshot save	*.png	No	Save a screenshot of the instrument
Test data	*.csv	No	Save test data
Table 4-1 Storage methods and uses			

4.2.3 Basic menu operation of file management

The various operations on the file are as follows:

The up and down keys and the knob of the arrow keys are used to move the file cursor up and down, and the left and right keys of the arrow keys are used to operate the expanded state of the current path;

Click to select the file name to be operated, and the operation can be performed as follows according to the toolbar on the right side of the screen:

- **Save .sta/.trt/.t40**

According to the main mode of the current test, it mainly corresponds to the LCR mode, the transformer single group mode, and the transformer sweep mode. The default menu is the corresponding file save menu. When the focus of the file list is under the files path, the measurement will be performed after inputting the file name. The setting file is saved in the root directory with the files file;

- **Copy to E:**

When the cursor is under the path corresponding to files, copy the file or folder corresponding to the cursor to the USB root directory;

Note: If the file to be copied is a file, it will overwrite the file in the usb path when there is a file with the same name in the usb; if the file to be copied is a folder, please make sure that there is no folder with the same name in the USB root directory, otherwise it will cause Copy failed.

- **Copy to I:**

When the cursor is under the path corresponding to usb, copy the file or folder corresponding to the cursor to the file root directory;

- **Delete**

The instrument will delete the file where the cursor is.

- **Load**

Load the setting file specified by the file index to reconfigure the parameter settings of the instrument;

- **Rename**

Rename the name of the file or folder at the cursor position;

Note: The root directory provided is not allowed to be modified.

- **New folder**

Create a new folder directory at the current cursor location; you can save a new test file in the newly created folder directory.

4.2.4 Operation steps for file management

Move the cursor: the arrow keys up and down and the knob can move the cursor;

Expand and contract: the left and right keys of the arrow keys can realize the expansion and zooming function of the folder.

4.2.4.1 File save

Move the cursor to the folder or any file in the folder where you want to save the setting file, and the corresponding menu area will display the file menu.

Load (If it is a loadable file type, this menu will be displayed)

Save

Copy to E:\

Rename

Delete

New folder

Press the **Save** soft key, the screen will display a numeric keyboard to input the file name, the file

name suffix is automatically generated, and there is no need to input the suffix;

After the input is confirmed, a named setting file will be generated in the current directory.

4.2.4.2 File load

When the cursor moves to the file type that can be loaded, the menu is displayed as above.

Move the cursor to the location of the file to be loaded in the file list. Or directly enter the file serial number.

Press the **Load** soft key, and the following confirmation dialog box will be displayed on the screen.

Load

Cancel

Pressing the soft key **No** will cancel the current loading operation and return to step 1.

After confirming by pressing **Load**, the currently selected file is loaded. After loading, it will intelligently return to the corresponding measurement display page.

4.2.4.3 File Copy

Move the cursor to the folder or file to be copied, the menu area will display

Copy to E:

Copy to I:

Press the key to **copy to E:**, copy the file to the root directory of the external storage USB disk of the instrument.

Press the key to **copy to I:**, and copy the file to the internal root directory of the instrument.

Note: Please make sure that your USB flash drive meets the standards described in this section and is not write-protected.

Chapter 5 Execute LCR measurement operation and some examples

5.1 Correction operation

To execute correction operation (in order to prevent the stray impedance from affecting the test accuracy, it is necessary to make open/short correction), users can select one of the two correction modes.

5.1.1 Sweep correction

Press the menu key [Cal] and the instrument will display the < Correction> page.

- Move the cursor to the **OPEN** zone. **ON**, **OFF**, **MEAS OPEN** and **DCR OPEN** will be displayed in the soft key zone.
Keep the test fixture be in the open status, then press **MEAS OPEN** to execute open correction till the prompt information zone displays that open correction is finished.
Press **ON** to turn on the open correction function.
Insert the short plate (TH26010) to the test fixture.
- Move the cursor to the **SHORT** zone. **ON**, **OFF**, **MEAS SHORT** and **DCR SHORT** will be displayed in the soft key zone.
Press **MEAS SHORT** to execute the short correction till the prompt information zone displays that the short correction is finished.
Press **ON** to turn the short correction function.
- Move the cursor to the **LOAD** zone. **ON**, **OFF** will be displayed in the soft key zone.
Press **OFF** to turn off the load correction function.
- Move the cursor to the **FREQ** zone, **ON**, **OFF**, **MEAS OPEN**, **MEAS SHORT** and **MEAS LOAD** will be displayed in the soft key zone.
Press **OFF** to turn off the point-frequency correction function of **FREQ**.

5.1.2 Point-frequency correction

This function will gain better results in single-frequency test.

If the test frequency is 5.5kHz,

Press the menu key [Cal] and the instrument will display the < Correction> page.

Move the cursor to the **FREQ** zone, **ON**, **OFF**, **MEAS OPEN**, **MEAS SHORT** and **MEAS LOAD** will be displayed in the soft key zone.

Press **ON** to turn on the point-frequency correction function of **FREQ**.

Press the key to input the specified frequency size of 5.5k. The frequency area will be changed to 5.5000kHz (the same as the test frequency).

Keep the test fixture be in open status and press **MEAS OPEN** to execute open correction.

Insert the short plate (TH26010) to the test fixture.
Press **MEAS SHORT** to execute short correction.

5.2 Correct connection of DUT

The instrument has H_{CUR} (current sampling high end Hc), L_{CUR} (current sampling low end Lc), H_{POT} (voltage sampling high end Hp), L_{POT} (voltage sampling low end Lp) and a total of four pairs of test terminals corresponding to the shielding end of each test terminal.

Each terminal contains shielding layer whose function is to reduce the influence of the ground stray capacitance and the interference of the electromagnetic field. In the process of testing, Hcur, Hpot and Lpot, Lcur should be connected with DUT lead to form a complete 4-terminal measurement, thus reducing the effect of the lead and the connection points on the test results (especially the dissipation measurement). When testing low-ohm components, Hpot, Lpot should be connected to the lead terminal so as to avoid the impedance being added to the lead impedance and the connection principle is that the Hpot and Lpot test should be the actual existed voltage on DUT.

In other words, before connecting to DUT, it is not recommended to connect Hcur, Hpot with Lpot, Lcur, for doing this will increase test error.

If the connection point and the lead resistance R_{lead} are far weaker than the tested impedance (for example: $R_{lead} < Z_x / 1000$, the accuracy error is required to be less than 0.1%), before connecting to DUT, it is recommended to connect Hcur, Hpot and Lpot, Lcur (Two terminal test).

In the test with high accuracy requirement, using Kelvin test fixture (standard accessory) will gain better results than using test leads. When Kelvin test lead is used under 10kHz, a better measurement result can be obtained. However, when the frequency is higher than 10kHz, it cannot meet the measurement demand. In high frequency, the change of the clearance between test leads will directly change stray capacitance and inductance on test terminals and this problem is unavoidable, because the test leads cannot be fixed in a position.

So, the use of the test fixture should be used as possible in high frequency. If the test fixture is unavailable or cannot be used, the status of test leads should be the same in the processes of correction and test.

No matter the standard Kelvin test fixture or Kelvin test leads or user-made fixture is used, the following requirements should be met.

1. Distribution impedance must be reduced to the Min. especially when testing high impedance components.
2. Contact resistance must be reduced to Min.
3. Short and open must be available between contact points. Open and short correction can easily reduce the influence of distribution impedance of the test fixture on measurement. For open correction, the clearance between test terminals should be the same with that when they connects with DUT. For short correction, the short plate of low impedance should be connected between test terminals. Another way is to directly connect Hc with Lc or Hp with Lp, then connect both.

Note: When the DUT is a polarity component, before testing, the high potential terminal should be connected to the terminal with mark “+”, “Hc” or “Hp” and the low terminal should be connected to the terminal with mark “-”, “Lc” or “Lp”.

Warning: Before testing, please discharge the tested polarity component so as to avoid the damage to the instrument.

5.3 Operation example for testing inductance

5.3.1 Test Condition

Function: Ls-Q

Frequency: 5.5kHz

Level: 1.5Vrms

Internal impedance: 100Ω

5.3.2 Operation steps

Turn on the instrument.

Set basic parameters.

Press [Display] to enter into the <Meas Display> page.

Move the cursor to the **Parameter** area, the optional parameters are in the soft key area on the right side of the screen.

Press Ls to select Ls test function.

Move the cursor to **FREQ**, the current frequency is 1.0000kHz. The frequency can be modified as needed.

Move the cursor to **LEVEL**, the current displayed level will be 1.000V.

Press [SETUP] to enter into the <MEAS SETUP> page.

Move the cursor to **R_{sou}** zone, 100Ω and 30Ω will be displayed in the soft key zone.

Press 100Ω to select 100Ω as the signal internal impedance.

Connect the test fixture (TH26005) to the test terminals.

Execute correction (To avoid the influence of stray impedance on measurement accuracy, Open/Short correction must be operated) (refer to 5.1.2 “Point-frequency correction”)

Mount the tested inductance to the test fixture.

Execute test operation.

Press [DISP] to enter into the < Meas Display > page. The instrument will continuously test and put the test result in the center of the page.

Meas Display						Display					
Frequency	1.00000kHz	Speed	Fast	DC Bias	0.000 V	Meas Display					
AC Level	1.000 V	AC Range	100kΩ	Vm	OFF	List Display					
DC Level	1.000 V	DC Range	100kΩ	Im	OFF	Trace Display					
Cp	0.00000 F	Dev	OFF	Ref	0.00000 F	Save					
D	0.00000	BIN1_H	----	BIN1_L	----	OFF					
Cp	0.00000 F	Dev	OFF	Ref	0.00000 F						
D	0.00000	BIN1_H	----	BIN1_L	----						
LAST	BIN1	BIN2	BIN3	BIN4	BIN5	BIN6	BIN7	BIN8	BIN9	BIN10	FAIL
----	0	0	0	0	0	0	0	0	0	0	0

2024/11/19 14:39:01

If the test result is obviously incorrect, please check the following items.

- a) Check the tested inductance is in good connection with the test fixture or not.
- b) Check the test fixture is in good connection with the test terminals of the instrument or not.
- c) Redo the open/short correction.

***NOTE:** When the sweep open/short correction is used, the point-frequency correction function should be set as OFF. Refer to Correction operation in this chapter.

5.4 Operation example of testing capacitance by multi-frequency list sweep

5.4.1 Test condition

Function: Cp, D

Level: 1Vrms

Other parameters

Frequency	Compare parameter	Low limit	High limit
1kHz	Cp (capacitance)	325.0nF	333.0nF
10kHz	D (Dissipation)	0.0001	0.0003
100kHz	D (Dissipation)	0.0060	0.0100

Sound: HIGH LONG

Alarm mode: OUT

5.4.2 Operation steps

Turn on the instrument.

5.4.2.1 Set basic parameters

Press [Display] to enter into the <Meas Display> page.

The **Parameter** zone is currently displayed as Cp, D and the Level zone is 1.000V.

Press [Setup] to enter into the <Meas Setup> page, meanwhile the following soft keys will be displayed in the soft key zone: Meas Setup, User Corr, Limit Setup, List Setup and File.

Press the **List Setup** button to enter into the <List Setup> page.

Press the knob to move the cursor to the parameter area of sweep point 1, modify the test conditions of the current point, including Frequency, Level, Bias, Limit, Delay, etc.

5.4.2.2 Sound setup

Press [System] to enter into the <System Setup> page.

Move the cursor to the **Fail Sound** zone to select **High Long**.

Mount the test fixture (TH26005) to the test terminals of the tester.

Execute correction function (To avoid the influence of the stray impedance on the measurement accuracy, it is necessary to execute open/short correction (refer to chapter 5.1.1 Sweep Correction)).

Insert the tested capacitor to the test fixture.

Execute test operations.

Press [Display] and then List Sweep to enter into the <List Sweep Display> page. The instrument will test continuously and then display the test and the compare results on page. If the compare result is Pass or Fail, there is a sound alarm. As shown below:

Pt	Freq	Level	Bias	Para1	Para2	Para3	Para4	P/F
1	1.00000kHz	1.000 V	0.000 V					
2	1.00000kHz	1.000 V	0.000 V					
3	1.00000kHz	1.000 V	0.000 V					
4	1.00000kHz	1.000 V	0.000 V					
5	1.00000kHz	1.000 V	0.000 V					
6	1.00000kHz	1.000 V	0.000 V					
7	1.00000kHz	1.000 V	0.000 V					
8	1.00000kHz	1.000 V	0.000 V					

If the test result is obviously incorrect, please check the following items.

Check the tested inductance is in good connection with the test fixture or not.

Check the test fixture is in good connection with the test terminals of the instrument or not.

Redo the open/short correction.

***NOTE:** When the sweep open/short correction is used, the point-frequency correction function should be set as OFF. Refer to Correction operation in this chapter.

5.5 Operation example of load correction

5.5.1 Operation steps

Assume that the test conditions used by the user are as follows:

Frequency: 100kHz. Cp standard value: 11nF D standard value: 0.0005

Press [Cal], the instrument will display the <User Corr> page.

Move the cursor to **Load**, the following soft keys will be displayed in the soft key zone: **ON** and **OFF**.

Press **ON** to turn on the load correction function.

Move the cursor to **Load Type**, Ls-Rs, Ls-Q, Cp-D, will be displayed in the soft key area on the right side of the screen.

Press **Cp-D** to select the Cp-D function.

Move the cursor to **Freq** zone, the following soft keys will be displayed in the soft key zone: **ON**, **OFF**, **OPEN**, **SHORT** and **LOAD**.

Press **ON** to turn on the point-frequency correction function of the corresponding **FREQ** in current correction point.

Input the correction frequency (100k), reference A (11nF), reference B (0.0005)

Move the cursor to **FREQ**. The following soft keys will be displayed: **ON**, **OFF**, **OPEN**, **SHORT** and **LOAD**.

Hold the test fixture be in open status and keep user's hands or other interference source be far away from the test fixture. Press the soft key **OPEN** to execute open correction.

Insert the short plate (TH26010) into the test fixture. Please ensure that the short plate and the reeds of the test fixture have good contact.

Press the soft key **SHORT** to execute short correction.

Insert a standard capacitance into the test fixture. Please ensure that the pins of the standard capacitance have good connection with the reeds of the test fixture.

Press the soft key **LOAD** to execute load correction.

5.5.2 Note

- a) Because of the different software editions, the soft keys and status information may be different from this book, but it may not affect users' understanding.
- b) The load correction is only valid for the components with the same specification. If the specification is changed, it is required to redo load correction.

Chapter 6 Transformer Single-machine Test

6.1 Circuit for transformer single-machine test

6.1.1 Some parameters of transformer

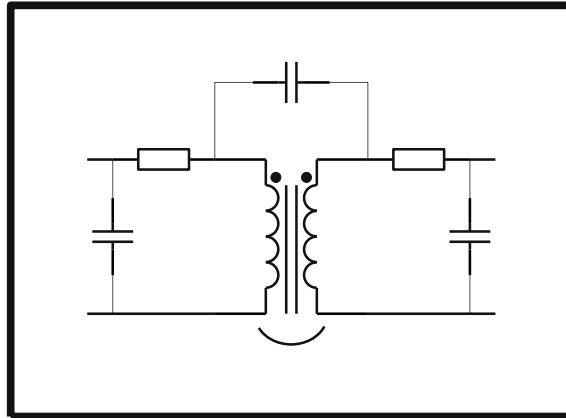

6.1.2 Transformer single test circuit and TURN test

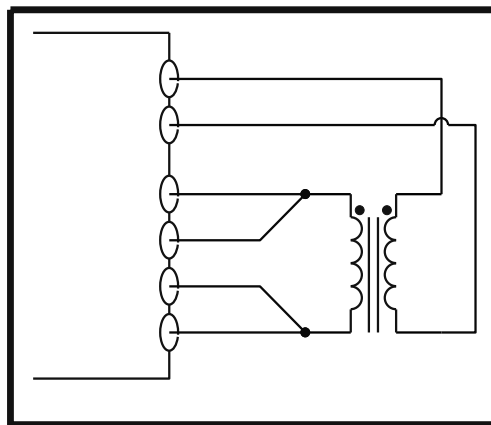

On TH2840X, TURN test has 4 display modes:

- $N_s: N_p$ $=U_2/U_1$
- $N_p: N_s$ $=U_1/U_2$
- N_s $=N_p*U_2/U_1$
- N_p $=N_s*U_1/U_2$

The above U_1 and U_2 are the values automatically measured by the instrument, and the values of N_p and N_s need to be set by the user in advance on the corresponding turns ratio parameters on the < Single Setup > page.

It is recommended that users put the winding group with more turns in primary winding rate, the reasons are as follows:

-
- 1) Due to the influence of output internal resistance (30, 100), when the primary inductance is too small, the distributed voltage signal is small and the transformer gets weak energy. As the test cable and relay will attenuate some energy, the stability and the accuracy of test will be affected.
 - 2) If the primary signal is enlarged, the secondary winding of the winding with more turns will generate higher voltage which may beyond the acceptable range thus affecting the test accuracy.
 - 3) If the winding group with more turns is put in primary class, then the transformer can get higher energy thus the two problems above can be avoided.

6.1.3 Transformer leakage inductance test

When use the circuit discussed in last section to make automatic sweep test on the leakage inductance of primary inductance L1, the instrument will automatically use the relay to short the secondary winding of the transformer so as to test the leakage inductance. From transformer secondary winding to inner relay, the magnetic leakage is existed inevitably, so there is error of leakage inductance in this zone. If user wants to obtain an accurate leakage value, please short the secondary winding of the transformer based on the figure below.

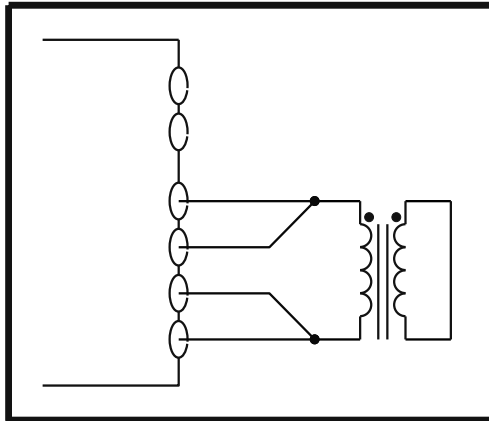

6.1.4 Capacitance test between windings of transformer

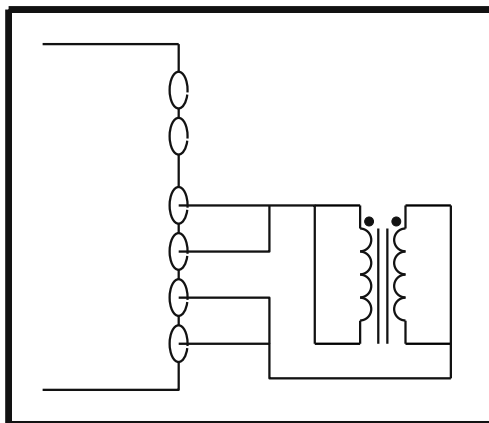

6.2 <Transformer Single Setup>

Press the shortcut key [Home] to enter the function selection interface, as shown in Figure 6-1-1.

Single Setup											Parameter		
Trigger	Continue		Speed		Fast		Test Mode		Seq				
Rsou	100Ω		Bias Source		100mA(40V)		Comp		OFF		Ls	Lp	Lk
Para	Freq(Hz)	Level(V)	Other	Dev	Nominal	Low	High	Delay	Avg	Meas	Cs	Cp	Zx
Ls	1.0000k	1.000	DCV : 1.000 V	OFF	0.0000 H	----	----	0 s	1	OFF	Rs	Rp	Rd
Lp	1.0000k	1.000	DCV : 1.000 V	OFF	0.0000 H	----	----	0 s	1	OFF	D	Q	dZ
Lk	1.0000k	1.000		OFF	0.0000 H	----	----	0 s	1	OFF	Ns	Ns:Np	
Cs	1.0000k	1.000		OFF	0.0000 F	----	----	0 s	1	OFF	Np	Np:Ns	
Cp	1.0000k	1.000		OFF	0.0000 F	----	----	0 s	1	OFF	Move Up		
Zx	1.0000k	1.000	DCV : 1.000 V	OFF	0.0000 Ω	----	----	0 s	1	OFF	Move Down		
Rs	1.0000k	1.000		OFF	0.0000 Ω	----	----	0 s	1	OFF	Help		
Rp	1.0000k	1.000		OFF	0.0000 Ω	----	----	0 s	1	OFF			
Rd		1.000		OFF	0.0000 Ω	----	----	0 s	1	ON			
D	1.0000k	1.000		OFF	0.0000	----	----	0 s	1	OFF			
Q	1.0000k	1.000	DCV : 1.000 V	OFF	0.0000	----	----	0 s	1	OFF			
dZ	1.0000k	1.000	DCV : 1.000 V	OFF	0.0000 °	----	----	0 s	1	OFF			

Figure 6-1-1 Single Setup

Move the cursor to the **Single Setup** area or directly touch the single group setting area to enter the <Single Setup> page.

This display function page is used to set transformer measurement parameters.

6.2.1 Trigger

See the trigger description in the LCR measurement setup chapter.

6.2.2 Speed

See the speed description in the LCR measurement setup chapter.

6.2.3 Test Mode

Move the cursor to **Test Mode**, the soft key zone will display **Seq** and **Step**.

- Press **Seq**, the **Test Mode** zone will display **Seq** which means the instrument is in single trigger mode, trigger once, the instrument will sweep the transformer parameter for a circle.
- Press **Step**, the **Test Mode** zone will displays **Step** which means the instrument is in single trigger mode, trigger once, the instrument will sweep the transformer parameter for one time.

6.2.4 Rsou

Move the cursor to the **Rsou** field, and the menu area on the right side of the screen will display: 100 Ω and 30 Ω .

Click the "100 Ω " area, the internal resistance area will display "100 Ω ", which means the output impedance of the instrument is 100 Ω , click the "30 Ω " area, the internal resistance area will display "30 Ω ", which means the output impedance of the instrument is 30 Ω . Please refer to the detailed introduction of output impedance.

6.2.5 Bias Source

Move the cursor to the bias source area, and the menu area on the right side of the screen will display: 100mA (40V), 2A.

Click on the "100mA(40V)" area, the bias source area will display "100mA(40V)", indicating that the 100mA(40V) bias source is selected. The bias source can output a maximum voltage of 40V when in voltage mode, and the maximum output current is 100mA when in current mode.

Click on the "2A" area, the bias source area will display "2A", indicating that the 2A bias constant current source is selected, and the bias source can output a maximum of 2A current in no voltage mode.

The setting here only selects the bias source and cannot set the actual output bias value. The actual output bias value needs to be set in the row where the actual test parameters are located.

For a detailed introduction of the bias source, please refer to the bias description in the LCR measurement setup chapter.

6.2.6 Comp

Move the cursor to the comparison area, the menu area on the right side of the screen will display: OFF and ON.

Click the "OFF" area, the comparison field will display "OFF", indicating that the comparison is turned off, and no sorting results will be output during the test. The PASS and FAIL lights on the front panel are off, the comparison column corresponding to the transformer measurement display interface will display "---", and the Handler interface sorting signal line has no sorting signal output.

Click the "ON" area, the comparison field will display "ON", indicating that the comparison is turned on, and the sorting result will be output during the test. The PASS or FAIL light on the front panel will be on, the comparison column corresponding to the transformer measurement display interface will display "pass" or "fail", and the Handler interface sorting signal line has a sorting signal output. Refer to 10.3 for details of sorting.

6.2.7 Parameter Setup

The parameter setting area is shown in Figure 6-1-1, with 12 rows and 11 columns. Each row corresponds to a parameter, and up to 12 parameters can be selected for measurement. Each column corresponds to a setting item of the corresponding parameter. The 11 columns are parameter,

6.3.1 Save the test results of a single set of transformers on the USB flash drive

Use the USB flash drive to save the test results. The test results and formats that can be saved are as follows:

Time, pt, para, val, COMP

---Respectively correspond to test time, point index, parameter name, parameter result, comparison result.

The states involved in data preservation are:

- Save the switch;
- Save path prompt, default path location: "usb/CSV/" path;
- The naming rule of the file name is trt+machine number+date, such as trt-SN12345678-20210811.csv,

Chapter 7 Transformer Auto Scanning Test

7.1 Introduction to scan test function

TH2840NX can rely on an internal scan board or use an external TH1901/TH1806/TH1831 transformer scan box to form a transformer automatic test system; TH2840AX/TH2840BX can only use an external scan box to form a test system (no internal scan board).

Note: If there is no functional difference, TH2840X will be used to replace the above three model descriptions.

At present, the test items that can be provided in the automatic scanning test of transformers include the number of turns (TURN), phase (PHASING), inductance (Lx), quality factor (Q), leakage inductance (Lk), stray capacitance (Cx), Impedance (Zx), AC Resistance (ACR), DC Resistance (DCR), balance (BALANCE), short circuit test (PIN-SHORT) and current bias (DCI-BIAS), etc.

TH2840X can realize the automatic conversion between transformer pins and fixture pins, automatic test time of rescan interval setup, multi-group primary winding test, multi-group leakage test, deviation compensation for test values, PASS and FAIL count for test result, save and load function for test parameter, repeat test for FAIL product, etc. Also, it can test several transformers at the same time.

7.2 Install and connect the scanning test system

Automatic transformer test system is the connection of TH1901/TH1806/TH2831 and TH2840X, and the connection steps are as follows:

Use 36PIN double-headed cable (TH26016 transformer test control cable) to connect the SCANNER socket on the rear panel of TH1901/TH1806/TH2831 and the SCANNER socket on the rear panel of TH2840X as shown in the following figure.

NOTE: It is forbidden to plug the cable with electricity. Keep the direction of cable be correctly routed.

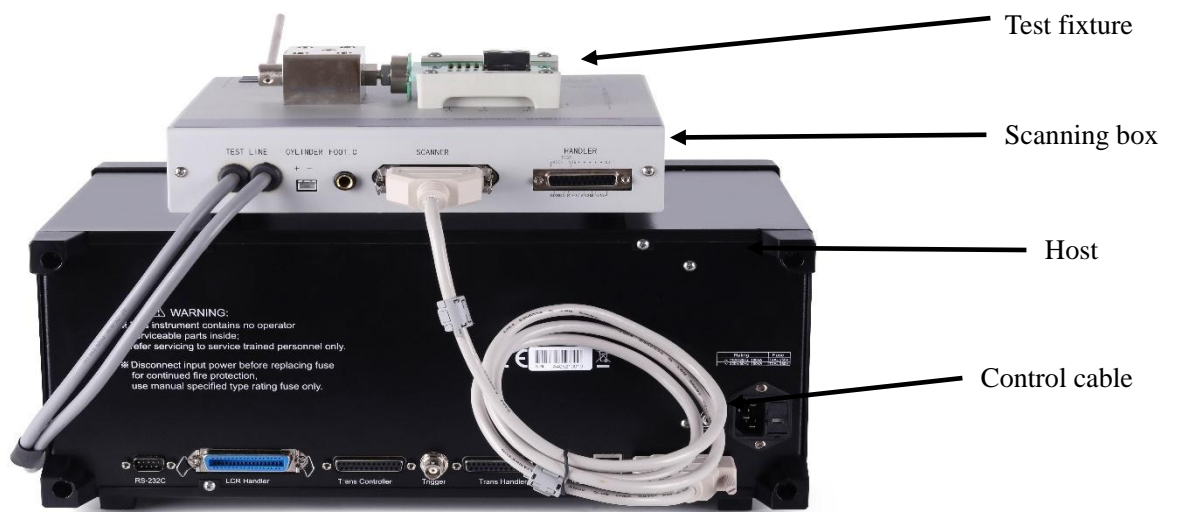

If it is necessary to use the foot switch, connect the foot switch to the FOOT.C interface on the rear panel of Test Fixture.

NOTE: Once the foot switch is used, the START button on the Test Fixture will not work.

If the scanning box is TH1901A, user should connect the trachea to the valve controller.

Connect TH1901L 6-terminal scanning box to the corresponding terminal on the front panel of TH2840X and lock it as shown in the following figure.

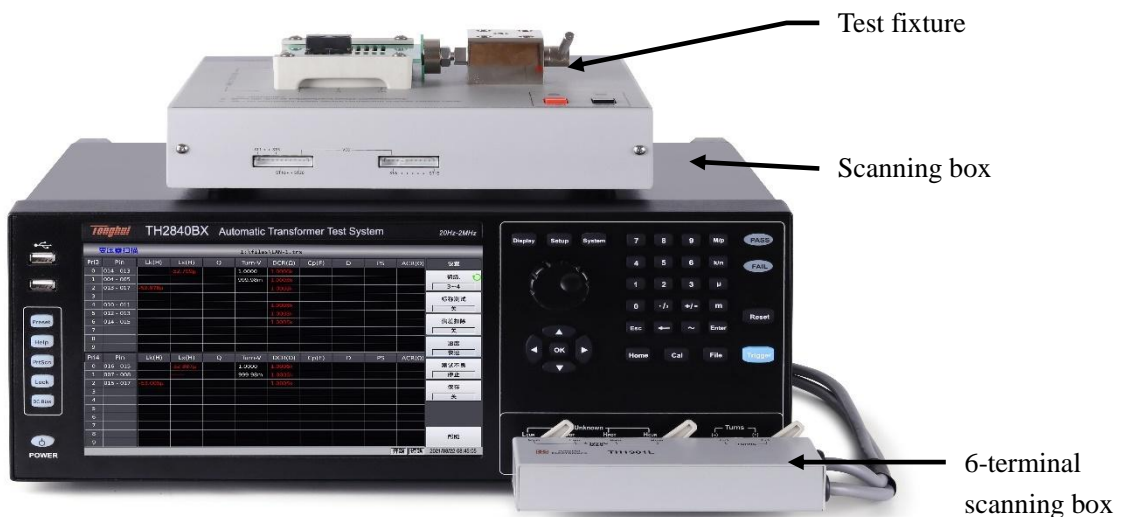

Connect the scanning test cable to TH2840X

7.3 Front panel of scanning box

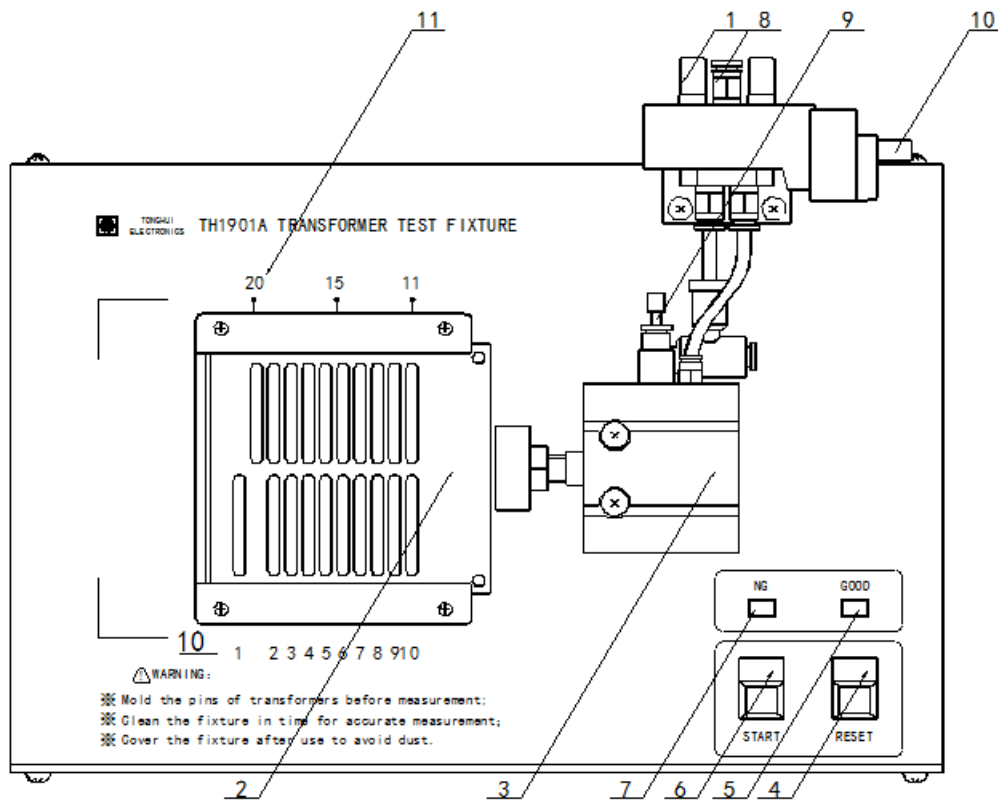

TH1901A Top Panel

Introduction to the marking numbers:

- 1) Silencer: This is a silencer used for noise reduction and dust proof (only for TH1901A).
- 2) Test fixture: This fixture is flexible and replaceable.
- 3) Cylinder: This is the main driving force for TH1901A; For TH1901B/TH1831, the motive force is from a manual push rod.
- 4) RESET button: When pressing this button, all tests will be terminated and the instrument will recover to the original preparing test state.
- 5) GOOD indicator: If the specified test results meet the preset requirements, this indicator will light up, which indicates that the tested device is GOOD.
- 6) START button: It is used to control test. Press this button, the instrument will start test.
- 7) NG indicator: If one or two test results cannot meet to the preset requirements, this indicator will light up, which indicates that the tested device is NOT GOOD.
- 8) Inlet of the air pipe: This is the connection interface connecting with external air pipe. Note: It is recommended to install a water filtering device between the inlet and the inlet valve so as to improve the service life of the cylinder and the inlet valve. (This inlet is unavailable for TH1901B/TH1831.)
- 9) Speed control knob: The knob is used to adjust the driving speed of the cylinder. (none for TH1901B/TH1831)
- 10) Control socket of air valve controller (electromagnetic valve): The switch for controlling TH1901A and the cylinder. The power is DC24V. There is no such a controller in TH1901B/TH1831.
- 11) Fixture pin number. In above figure, 1~20/24 is the corresponding pin number.

7.4 Rear panel of scanning box

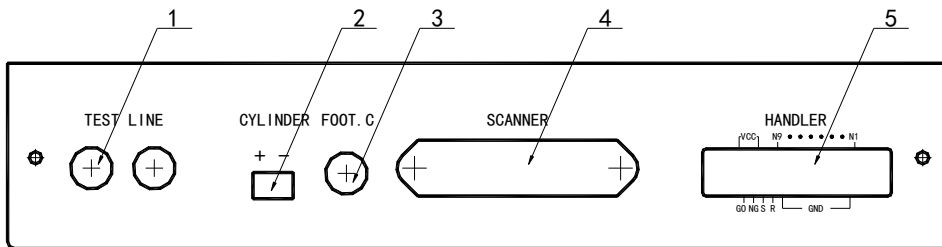

Introduction to each number on the lower panel

1. TEST LINE: inlet port of the test cable, TH1901L 6-terminal test box is connected to inner part of TH1901A/B through this line.
2. CYLINDER: 24V DC voltage output terminal, providing the working voltage for TH1901A solenoid valve.
3. FOOT. C: Used to connect footswitch.
4. SCANNER: Signal control port. Use TH26016 control line to connect the scanning box with TH2840X through SCANNER port.
5. HANDLER: HANDLER port. Refer to section 7.5 for instruction of HANDLER port.

NOTE: There is a hole in the left panel of TH1901A/B, the inner adjustable potentiometer can be sued to adjust the volume of beep.

7.5 HANDLER interface

7.5.1 Timing diagram of HANDLER signal

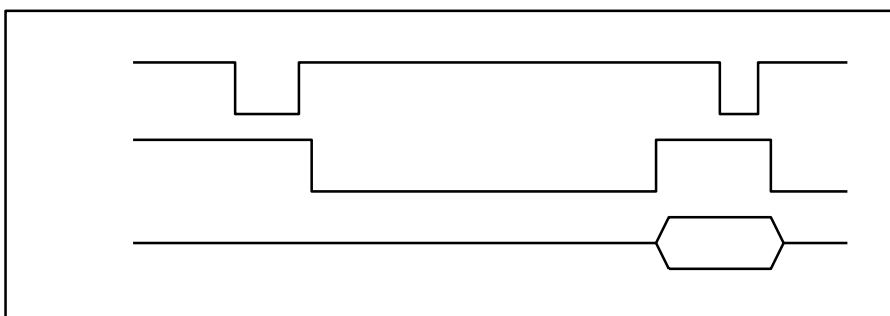

7.5.2 Distribution and connection diagram for HANDLER

The distribution and external circuit of HANDLER signal pin:

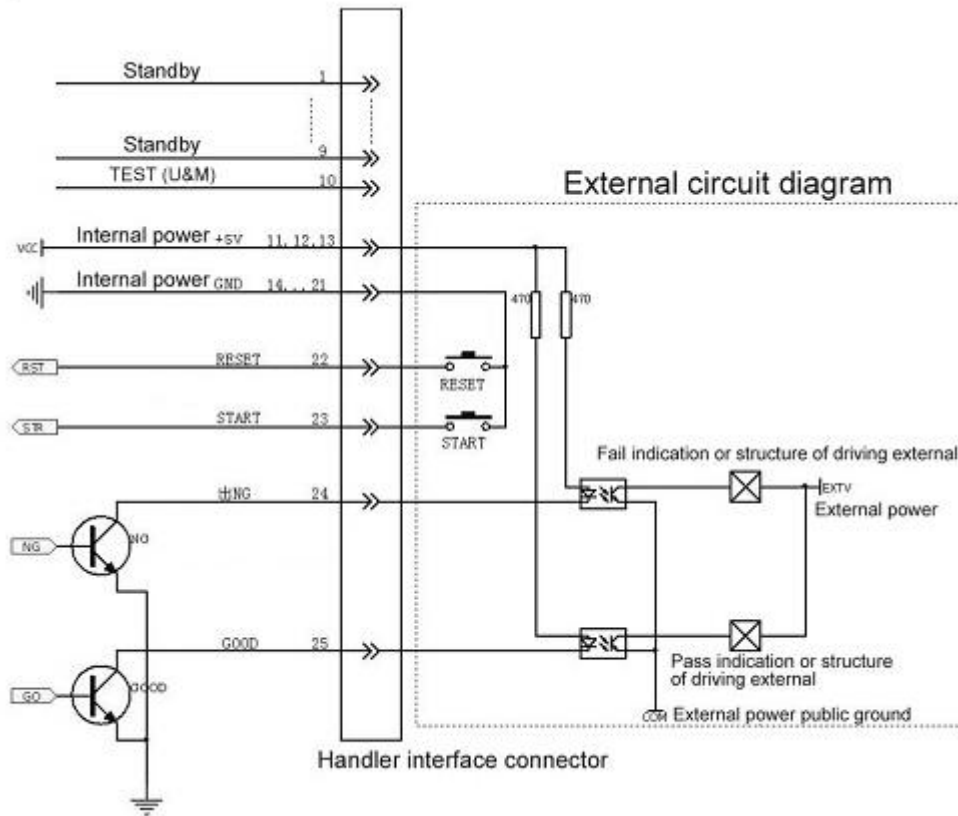

7.6 Example of transformer

In order to understand the operation of transformer scanning test, the setting figures listed in the following chapters are based on the sample below.

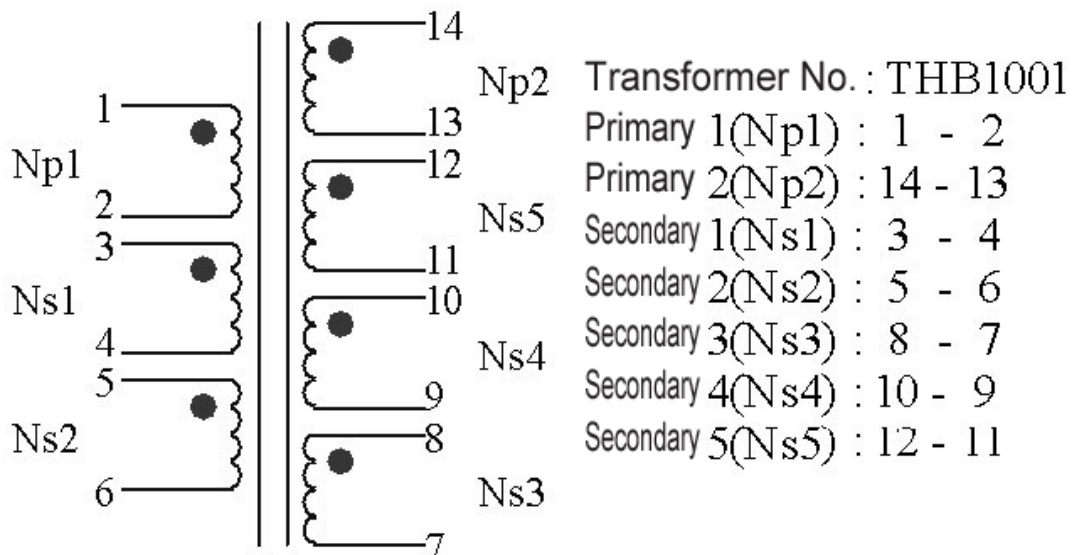

The detailed information will be described in latter sections.

7.7 Clear Settings

Before starting a new transformer ID test condition setting, the user must execute the **Clear Settings** to clear the unpredictable data that may exist in the memory of the instrument and prevent unpredictable errors during the test of the newly set test condition.

The execution method is as follows:

On any transformer sweep function page, press the button **Preset** on the left side of the front panel to select the function **Clear Settings**.

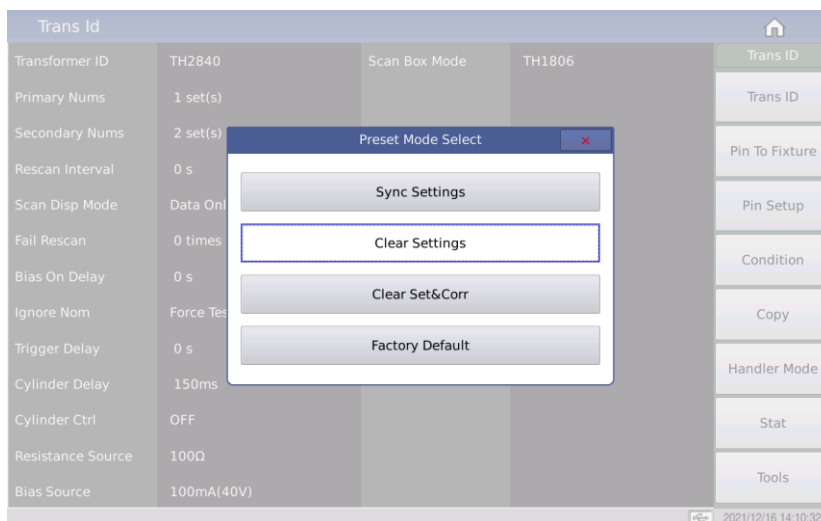

The user can also reset the transformer setting parameters by restarting the instrument.

7.8 <Transformer ID>

When the instrument function is **Trans Scan**, press the **Setup** button above the knob to enter the <Trans ID> page. As shown below:

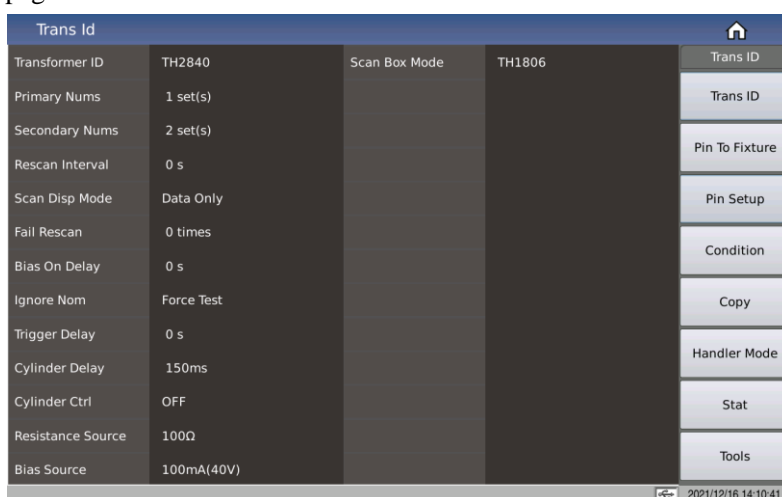

The <Transformer Number> page contains parameters such as: Transformer ID, Primary and Secondary Nums, Rescan Interval, Scan Disp Mode, Fail Rescan, Bias On Delay, ignore Nom, Trigger Delay, Cylinder Delay, Cylibder Ctrl, Scan Box Mode, Resistance Source, Bias Source, and other function setting areas.

7.8.1 Transformer ID

You can input the transformer ID to be tested in this area. The setting method is as follows: Press the menu function **Input**, select the desired character in the soft keyboard, press **Esc** to cancel, press **Enter** to apply the entered transformer ID.



7.8.2 Primary Nums

You can input the number of transformer primary groups in this area. For transformers with multiple cores, multiple PRIs may be set. The primary numbers range from 1 to 60.

7.8.3 Secondary Nums

You can input the number of transformer secondary groups in this area. The secondary numbers range from 1 to 9.

7.8.4 Rescan Interval

In this area, you can enter the interval time for automatic continuous testing. The range of automatic test interval is 0~60s; 0 means no automatic continuous test. The maximum scan interval is 60 seconds.

7.8.5 Scan Disp Mode

This area is used to set the overall judgement display options, and is used to control the display mode of the results during the scanning test of the transformer. There are 3 modes:

Data mode: It means that the test data of each parameter is displayed one by one during the scanning process, but there is no general PASS/FAIL large-character display, which is convenient

for users to view.

Judgement result mode: It means that the test data of each parameter is displayed one by one during the scanning process, and the total PASS/FAIL is displayed in large characters after it is finished.

Fail list: It means that the test data of each parameter is displayed one by one during the scanning process, and the unqualified parameters and their limit settings are displayed in the center of the screen after it is finished.

7.8.6 Fail Rescan

This area is used to set the number of retests for defective products. It is used to set the number of retests in order to prevent a certain parameter from being defective due to interference during the automatic scanning test process, thereby increasing the yield of good products.

Retest range of defective products: 0-9 times.

7.8.7 Bias On Delay

This area is used to set the delay when applying DC current bias test.

Current bias delay range: 0~60s; 0 means no delay.

The maximum test delay is 60 seconds.

7.8.8 Ignore Nom

This area overlaps 2 functions, one is to ignore the nominal value for testing, and the other is the deviation deduction limit. All are related to the nominal value. They are as follows:

FORCE DEV: When this option is selected, the user will not be restricted by the set nominal value (STD) when deducting deviation. That is, it can be deducted when the deviation between the test value and the set nominal value (STD) is large. For example, when the user inserts the wrong pin of the transformer.

FORCE TEST: When this option is selected, as long as the winding pin is set, the parameter to be tested for the winding can be measured without setting the nominal value. It is convenient for users to test and observe when they do not know the nominal value of the transformer sample. This is generally not used.

SKIP TEST LMTED DEV: When this option is selected, it means that the pin position of the winding is set but the nominal value of the parameter to be tested is not set, then the parameter to be tested will not be measured during the test; this The mode will be limited by the nominal value when the deviation is deducted. When the user's test value deviates greatly from the set nominal value (STD), the deduction will not succeed.

7.8.9 Trigger Delay

This area is used to set the delay time from when the instrument is triggered to the start of sweep measurement.

Delay range: 0~60s; 0 means no delay.
The maximum test delay is 60 seconds.

7.8.10 Cylinder Ctrl

This area is used to set the switch of cylinder 24V power.

ON: Output of 24V cylinder power is allowed during scanning.

OFF: Output of 24V cylinder power is forbidden during scanning.

FAIL HOLD: the test is stopped when a defective product is encountered during scanning.

FAIL LOCK: the test is stopped when a defective product is encountered during scanning, and the system is locked.

7.8.11 Scan Box Mode

This area is used to set the test fixture used when the instrument scans.

Internal: It means that the internal scanning board of the instrument is used during the test, which is only equipped with TH2840NX.

TH1831: It means that the TH1831 scan box is used in the test.

TH1806: It means that the TH1806 scan box is used during the test, which is compatible with the TH1901 scan box.

Note: This function needs to be selected according to the fixture used in the actual situation. Inconsistent selection will cause the instrument to fail to obtain correct test results.

7.8.12 Resistance Source

TH2840X provides two output resistances to choose from: 100 Ω , 30 Ω .

When testing inductance, in order to compare data with other types of testers, it is necessary to ensure the same output resistance value.

When measuring some magnetic cores with very high permeability, use 100 Ω internal resistance to reduce the degree of polarization of the magnetic core, which can improve the accuracy and stability of the test.

Note: When using bias current output, the default is 100 Ω .

7.8.13 Bias Source

The bias source function is used to select the DC bias source used by the instrument. The transformer scan only provides two bias sources as follows:

100mA (40V) mode: The transformer scan test uses a DC bias current source (0~100mA).

2A mode: The transformer scan test uses a DC bias current source (0~2A).

Note: When the DC bias source is enabled, only 100 Ω output resistance can be used.

7.9 Trans Pin To Fixture

On the <Trans ID> page, press the menu key **Trans Pin**, it will jump to the <Trans Pin To Fixture> page.

This page is used to connect the pin of the transformer to the pin of the test fixture, and to convert the pin number into a custom pin label.

Trans Pin To Fixture													Trans Pin
[A] + [B]	[C] + [D]		[E] + [F]		[G] + [H]		[I] + [J]		[K] + [L]				Allocate
FRC [A]	A01	A02	A03	A04	A05	A06	A07	A08	A09	A10	A11	A12	Auto
Trans Pin	001	002	003	004	005	006	007	008	009	010	011	012	Clear FRC Pins
Pin Label	001	002	003	004	005	006	007	008	009	010	011	012	Clear All FRC Pins
FRC [A]	A13	A14	A15	A16	A17	A18	A19	A20	A21	A22	A23	A24	
Trans Pin	013	014	015	016	017	018	019	020	021	022	023	024	
Pin Label	013	014	015	016	017	018	019	020	021	022	023	024	
FRC [B]	B01	B02	B03	B04	B05	B06	B07	B08	B09	B10	B11	B12	
Trans Pin	025	026	027	028	029	030	031	032	033	034	035	036	
Pin Label	025	026	027	028	029	030	031	032	033	034	035	036	
FRC [B]	B13	B14	B15	B16	B17	B18	B19	B20	B21	B22	B23	B24	
Trans Pin	037	038	039	040	041	042	043	044	045	046	047	048	
Pin Label	037	038	039	040	041	042	043	044	045	046	047	048	

7.9.1 Pin To Fixture Setup

The default state of the instrument when the instrument is turned on: the transformer pins correspond to the fixture pins one-to-one. Normally, when using the internal scanning board of the instrument, you only need to connect the transformer pins to the fixture pins on the rear panel of the instrument one-to-one and it can be tested; the external scanning test box (TH1831, TH1806, etc.) can be connected according to 1~20/24 marked on the front of the test box. If you use the above setting method, you can skip the pin to fixture setup here.

Here is the manual setting method:

The setting method is as follows: (The figure below is the corresponding relationship between the sample transformer pin 1 and the fixture pin 2)

1. Click any cell of the transformer pin in the table, the menu bar will display related menu functions;
2. Select the function to **Clear All FRC Pins** to clear the default settings;
3. Press the function key to **Allocate** and change the allocate function option from Auto to manual.
4. When manually associating, move the cursor to the corresponding fixture pin position and input the corresponding transformer pin.

Note: Input 0 to clear the corresponding pin input.

When the Allocate function is **Auto**, it will automatically +1 the number of pins at the transformer pin where the first number is entered, until the input box of the last transformer pin.

Trans Pin To Fixture													Trans Pin
[A] + [B]	[C] + [D]	[E] + [F]	[G] + [H]	[I] + [J]	[K] + [L]							Allocate	
FRC [A]	A01	A02	A03	A04	A05	A06	A07	A08	A09	A10	A11	A12	Manual
Trans Pin		001	002	003	004	005	006	007					Clear FRC Pins
Pin Label	001	002	003	004	005	006	007	008	009	010	011	012	Clear All FRC Pins
FRC [A]	A13	A14	A15	A16	A17	A18	A19	A20	A21	A22	A23	A24	
Trans Pin	008	009	010	011	012	013	014						
Pin Label	013	014	015	016	017	018	019	020	021	022	023	024	
FRC [B]	B01	B02	B03	B04	B05	B06	B07	B08	B09	B10	B11	B12	
Trans Pin													
Pin Label	025	026	027	028	029	030	031	032	033	034	035	036	
FRC [B]	B13	B14	B15	B16	B17	B18	B19	B20	B21	B22	B23	B24	
Trans Pin													
Pin Label	037	038	039	040	041	042	043	044	045	046	047	048	

7.9.2 Pin Label Setup

The transformer pin label function can convert the transformer pin that was originally only represented by numbers into the transformer pin represented by custom numbers or letters. As shown below:

Trans Pin To Fixture													Pin Label
[A] + [B]	[C] + [D]	[E] + [F]	[G] + [H]	[I] + [J]	[K] + [L]							Input	
FRC [A]	A01	A02	A03	A04	A05	A06	A07	A08	A09	A10	A11	A12	Default Item Label
Trans Pin		001	002	003	004	005	006	007					Default FRC Labels
Pin Label	P01	P02	P11	P12	P21	P22	P32	P31	P42	P41	P52	P51	Default All FRC Labels
FRC [A]	A13	A14	A15	A16	A17	A18	A19	A20	A21	A22	A23	A24	
Trans Pin	008	009	010	011	012	013	014						
Pin Label	P62	P61	015	016	017	018	019	020	021	022	023	024	
FRC [B]	B01	B02	B03	B04	B05	B06	B07	B08	B09	B10	B11	B12	
Trans Pin													
Pin Label	025	026	027	028	029	030	031	032	033	034	035	036	
FRC [B]	B13	B14	B15	B16	B17	B18	B19	B20	B21	B22	B23	B24	
Trans Pin													
Pin Label	037	038	039	040	041	042	043	044	045	046	047	048	

After setting the transformer pin label and related test conditions, it can be displayed in the PIN (pin) column in the transformer test interface as a custom transformer pin label (to be updated).

7.10 Pin Setup

Press the function key **Pin Setup** on the <Trans ID> page, and it will go to the <Trans Pin> page. This page is used to set the pins of each winding of the transformer, connect the pins in series, and connect in parallel. Please see the following example transformer and its pin setting screen:

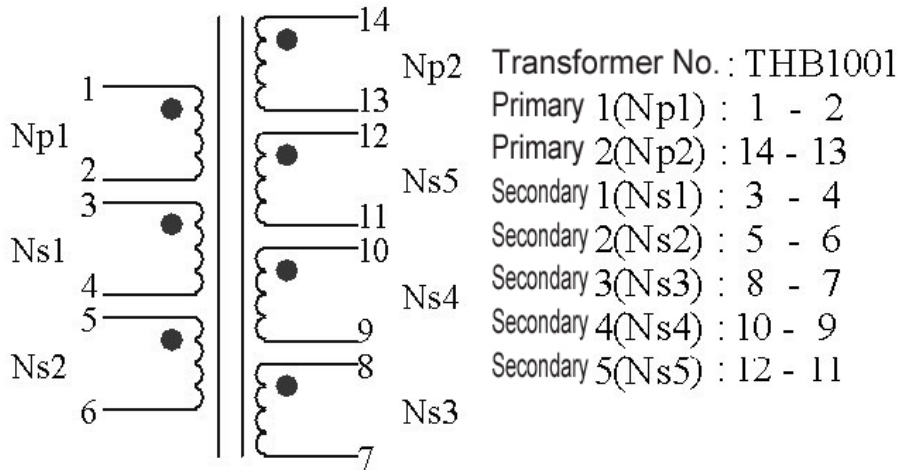

7.10.1 Trans Pin Setup

The following is the pin setting screen of PRI: A1 (PRI: A1 is used for Np1 as the primary winding):

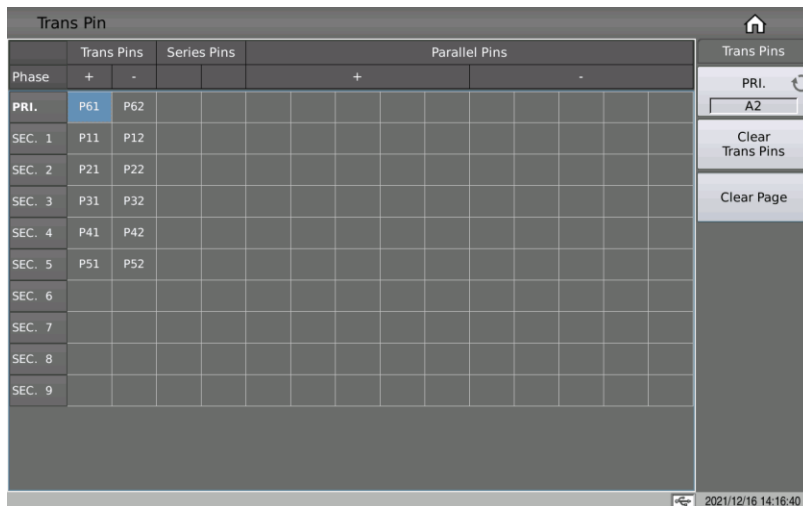

The following is the pin setting screen of PRI: A2 (PRI: A2 is used for Np2 as the primary winding):

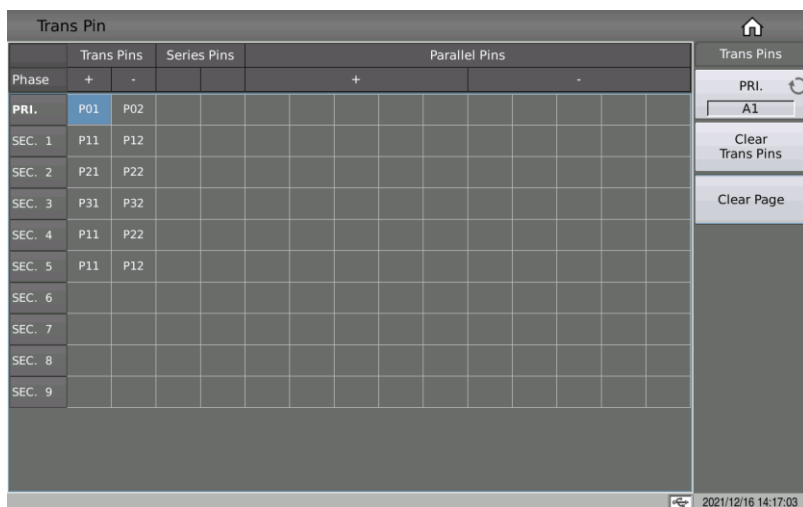

7.10.2 Series Pins Setup

Before setting the transformer series pin, you need to confirm the parameters of the series test. For example, the Lx inductance needs to set the series pin. You can select the function Lx in the parameter menu bar, and then input the series pin (there is no back and forth order of the pin).

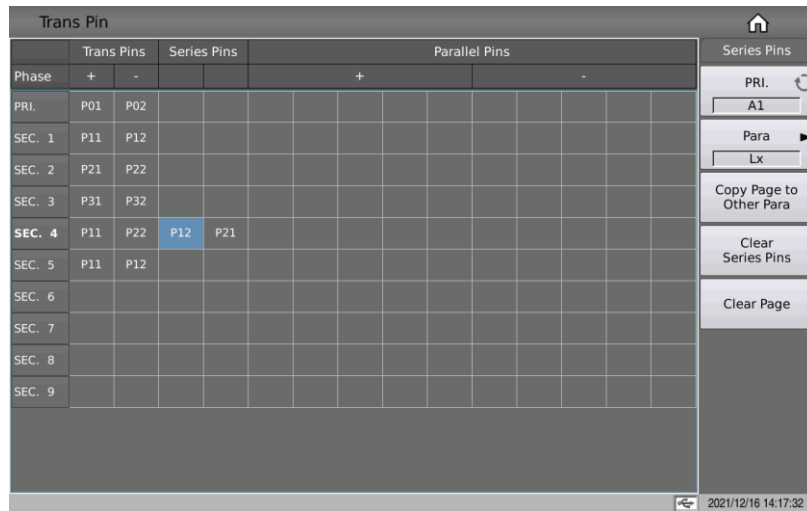

The above is: the short-circuit pin setting when series transformers Ns1 and Ns2 test Lx.

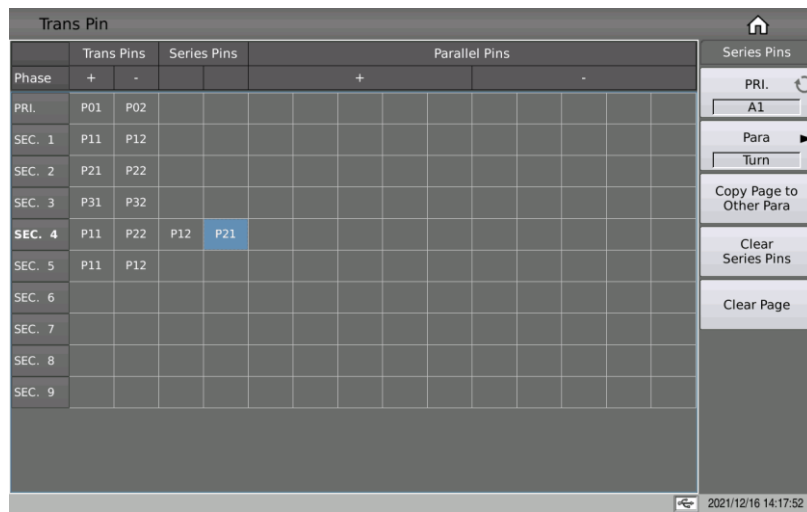

The above is: the short-circuit pin setting when series transformers Ns1 and Ns2 test TURN.

7.10.3 Parallel Pins Setup

Before setting the transformer parallel pins, you need to confirm the parameters for parallel testing. For example, the TURN turns ratio needs to set the parallel pins. You can select the function Turn in the parameter menu bar, and then input the parallel pins.

The above is: Above figure shows the short pin setup of the "+" and "-" terminal when example parallel transformers Ns1 and Ns2 tests.

7.11 <Trans Condition>

This page contains two tables:

The table above is the parameter test condition table, which is mainly used to set the parameters and test conditions of the transformer under test. The parameters that can be measured are: Turn (number of turns), Phase (phase), Lx (inductance), Q (quality factor), L.K. (leakage inductance), Cx (distributed capacitance between turns), D (loss), Zx (Impedance), ACR (AC resistance), DCR (DC resistance), PS (pin short-circuit detection), BAL (balance). You can also change the scan order of each parameter and set the test frequency, test voltage, test mode, etc. of each parameter.

The table below is the parameter limit setting table, which is mainly used to set the nominal value and upper and lower limits of each parameter for sorting.

Trans Condition									
	Turn	Lx	Lk	Cx	Zx	ACR	DCR	PS	BAL
Freq(Hz)	10.0000k	10.0000k	10.0000k	10.0000k	10.0000k	10.0000k			
Level	1 V	300mV	300mV	300mV	300mV	300mV	2 V	2 V	
Dev	OFF	OFF	OFF	OFF	OFF	OFF	OFF		
Average	1	1	1	1	1	1	1	1	
Delay	0 s	0 s	0 s	0 s	0 s	0 s	0 s	0 s	
Equ		Series	Series	Parallel		Series			
Sequence	1	2	3	4	5	6	7	8	9
Switch	ON	ON	ON	ON	ON	ON	ON	ON	ON

Turn	Pins	Phase	Std(T)	Low	High	Short Pins
0	P01-P02	+	1.0000			
1	P11-P12	+				
2	P21-P22	+				
3	P31-P32	+				
4	P11-P22	+				
5	P11-P12	+				
6		+				
7		+				
8		+				
9		+				

7.11.1 Frequency, voltage, switch and scanning sequence

There are multiple parameter variables corresponding to each parameter: frequency, level, deviation,

average, delay, equivalence, scan sequence and switch. Touch or move the cursor to the corresponding setting area and modify the corresponding parameters according to the menu prompts to meet user needs.

Note:

- Frequency range: 20Hz~2MHz.
- Test level: 5mV~20V.
- Deviation: Off, Δ%; this parameter is used to set the sorting method, the same as the limit mode of TH2829X series.

OFF: The test results are sorted directly according to the set upper and lower limits.

Δ%: The difference between the test value and the nominal value divided by the nominal value will be sorted according to the set upper and lower limits.

- Average times: 1~255. Perform multiple tests according to the set average times, and display the results after calculating the average value. This function can also be used to adjust the test speed of a single parameter.
- Delay: 0~60s, the delay between the trigger test and the test. This function can improve the stability and accuracy of the test.
- Equivalence: series, parallel.
- Sequence: the default number of the scanning sequence is 1-9 from left to right, you can enter the number 1-8 to change, and BAL is fixed as the last item 9.
- Switch: If you choose to ON, the corresponding parameter is valid, otherwise the corresponding parameter is invalid.

7.11.2 TURN Test Conditions Setup

On the <Trans Conditions> page, touch or move the cursor to the Turn column of the test condition table to set the Turn parameters.

Trans Condition									
	Turn	Lx	Lk	Cx	Zx	ACR	DCR	PS	BAL
Freq(Hz)	10.0000k	10.0000k	10.0000k	10.0000k	10.0000k	10.0000k			
Level	1 V	300mV	300mV	300mV	300mV	300mV	2 V	2 V	
Dev	OFF	OFF	OFF	OFF	OFF	OFF	OFF		
Average	1	1	1	1	1	1	1	1	
Delay	0 s	0 s	0 s	0 s	0 s	0 s	0 s	0 s	
Equ		Series	Series	Parallel		Series			
Sequence	1	2	3	4	5	6	7	8	9
Switch	ON	ON	ON	ON	ON	ON	ON	ON	ON

Turn	Pins	Phase	Std(T)	Low	High	Short Pins
0	P01-P02	+	1.0000			
1	P11-P12	+				
2	P21-P22	+				
3	P31-P32	+				
4	P11-P22	+				
5	P11-P12	+				
6		+				
7		+				
8		+				
9		+				

7.11.2.1 Turn Mode

When touching the TURN setting area or moving the cursor to the TURN setting area, the TURN mode can be set in the menu on the right.

TH2840X test TURN can choose the following 8 modes:

- **TURN_v** = primary standard value * secondary voltage/ primary voltage. This mode is used test transformer turn number.
- **TURN** = primary standard value * secondary turn/ primary turn. When the primary inductance is small, using this mode can test the turn number more accurately. But, when testing magnetic core with high magnetic conductivity, in such mode, the data will be unstable due to the polarized magnetic core.
- **VOLT** = Primary test voltage * secondary voltage / primary voltage
- **Vs:Vp** = Secondary voltage/ primary voltage
- **Ns:Np** = Secondary turn/ primary turn
- **TURN_L** = Inductance ratio mode
- **Np:Ns** = Primary turn/ secondary turn
- **Lp:Ls** = Primary inductance/ secondary inductance

It is recommended to put the windings with multi-turns in the primary turn ratio, the reasons are as follows:

1. By the influence of output internal resistance (30, 100), when the primary inductance is small, the distributed voltage signal will also be small and the energy the transformer gets is also weak. The test cable and the relay will attenuate a part of energy, so the stability and accuracy will be affected.
2. If the primary signal is forced to be enlarged, then the voltage generated by secondary multi-winding will be high and it may be over the range of the instrument and thus further affect the test accuracy.
3. If the winding with multi-turns is put in primary test, then the energy of the transformer will be strong and above 2 problems can be ignored.

Trans Condition										Home
	Turn	Lx	Lk	Cx	Zx	ACR	DCR	PS	BAL	Turn
Freq(Hz)	10.0000k	10.0000k	10.0000k	10.0000k	10.0000k	10.0000k				Turn
Level	1 V	300mV	300mV	300mV	300mV	300mV	2 V	2 V		Turn
Dev	OFF	OFF	OFF	OFF	OFF	OFF	OFF	OFF		Volt
Average	1	1	1	1	1	1	1	1		Ns:Np
Delay	0 s	0 s	0 s	0 s	0 s	0 s	0 s	0 s		Vs:Vp
Equ		Series	Series	Parallel		Series				Turn_V
Sequence	1	2	3	4	5	6	7	8	9	Np:Ns
Switch	ON	ON	ON	ON	ON	ON	ON	ON	ON	Turn_L
Turn	Pins	Phase	Std(T)	Low	High	Short Pins				Lp:Ls
0	P01-P02	+	1.0000							Return
1	P11-P12	+								
2	P21-P22	+								
3	P31-P32	+								
4	P11-P22	+								
5	P11-P12	+								
6		+								
7		+								
8		+								
9		+								

7.11.2.2 Turn Limits Setup

The turns ratio limit setting table is used to set the nominal value, upper and lower limits, phase and short-circuit pins of each winding of the transformer.

Touch the TURN limit setting table, or move the cursor to the TURN limit setting area, and use the number keys, the corresponding magnification or the [ENTER] key to set.

The magnification corresponding to TURN is M, k, μ , m, and the [ENTER] key is x1.

Trans Condition										
	Turn	Lx	Lk	Cx	Zx	ACR	DCR	PS	BAL	
Freq(Hz)	10.0000k	10.0000k	10.0000k	10.0000k	10.0000k	10.0000k	10.0000k			
Level	1 V	300mV	300mV	300mV	300mV	300mV	2 V	2 V		
Dev	OFF	OFF	OFF	OFF	OFF	OFF	OFF			
Average	1	1	1	1	1	1	1	1		
Delay	0 s	0 s	0 s	0 s	0 s	0 s	0 s	0 s		
Equ		Series	Series	Parallel		Series				
Sequence	1	2	3	4	5	6	7	8	9	
Switch	ON	ON	ON	ON	ON	ON	ON	ON	ON	

Turn	Pins	Phase	Std(T)	Low	High	Short Pins
0	P01-P02	+	1.0000			
1	P11-P12	+	200.00	198.00	202.00	
2	P21-P22	+				
3	P31-P32	+				
4	P11-P22	+				
5	P11-P12	+				
6		+				
7		+				
8		+				
9		+				

7.11.2.3 Turn Phase Setup

When setting the limit of the number of turns, you can set the secondary winding phase for sorting, "+" means the same direction, and "-" means the reverse direction.

The phase of the primary winding is used as the reference phase and cannot be modified. When the measured phase of the secondary winding is inconsistent with the phase set here, it will be judged as unqualified.

The default setting of the instrument is opposite to the primary phase, which means the phase is unqualified.

Trans Condition										
	Turn	Lx	Lk	Cx	Zx	ACR	DCR	PS	BAL	
Freq(Hz)	10.0000k	10.0000k	10.0000k	10.0000k	10.0000k	10.0000k	10.0000k			
Level	1 V	300mV	300mV	300mV	300mV	300mV	2 V	2 V		
Dev	OFF	OFF	OFF	OFF	OFF	OFF	OFF			
Average	1	1	1	1	1	1	1	1		
Delay	0 s	0 s	0 s	0 s	0 s	0 s	0 s	0 s		
Equ		Series	Series	Parallel		Series				
Sequence	1	2	3	4	5	6	7	8	9	
Switch	ON	ON	ON	ON	ON	ON	ON	ON	ON	

Turn	Pins	Phase	Std(T)	Low	High	Short Pins
0	P01-P02	+	1.0000			
1	P11-P12	-	200.00	198.00	202.00	
2	P21-P22	+				
3	P31-P32	+				
4	P11-P22	+				
5	P11-P12	+				
6		+				
7		+				
8		+				
9		+				

7.11.2.4 TURN Turn-Ratio Short Pins

When setting the turns ratio short pins, you can use the soft key. and ~ to input multiple pins, the maximum number of pins can be saved here is 48.

Example:

1: Input a discontinuous number "1, 3, 5, 7, 9" and use the soft key. to separate each number, press

ENTER to confirm, the final data displayed in the table is (1, 3, 5, 7, 9).

2: Input a continuous number of "1,2,3,4,5,6,7,8,9", first input the number "1", then press the soft key ~, finally input "9", press the **ENTER** key to confirm. After that, the data finally displayed in the table is (1~9).

Note: The maximum number of turns ratio short pins is 48 and some pins after the excess will be ignored.

3: Input part of continuous numbers and non-continuous numbers "1,2,3,4,5,7,9", the continuous part is the same as step 2, the discontinuous part is the same as step 1, press **ENTER** to confirm, and the data finally displayed in the table is (1~5,7,9).

Trans Condition									
	Turn	Lx	Lk	Cx	Zx	ACR	DCR	PS	BAL
Freq(Hz)	10.0000k	10.0000k	10.0000k	10.0000k	10.0000k	10.0000k			
Level	1 V	300mV	300mV	300mV	300mV	300mV	2 V	2 V	
Dev	OFF	OFF	OFF	OFF	OFF	OFF	OFF		
Average	1	1	1	1	1	1	1	1	
Delay	0 s	0 s	0 s	0 s	0 s	0 s	0 s	0 s	
Equ		Series	Series	Parallel		Series			
Sequence	1	2	3	4	5	6	7	8	9
Switch	ON	ON	ON	ON	ON	ON	ON	ON	ON

Turn	Pins	Phase	Std(T)	Low	High	Short Pins
0	P01-P02	+	1.0000			
1	P11-P12	-	50.000	48.000	52.000	P21~P31
2	P21-P22	+	50.000	48.000	52.000	
3	P31-P32	+	30.000	28.000	32.000	
4	P11-P22	+	100.00	96.000	104.00	
5	P11-P12	+				
6		+				
7		+				
8		+				
9		+				

7.11.3 Lx Test Conditions Setup

On the <Trans Condition> page, touch or move the cursor to the Lx column of the test condition table to set the Lx parameters.

Trans Condition									
	Turn	Lx	Lk	Cx	Zx	ACR	DCR	PS	BAL
Freq(Hz)	10.0000k	10.0000k	10.0000k	10.0000k	10.0000k	10.0000k			
Level	1 V	300mV	300mV	300mV	300mV	300mV	2 V	2 V	
Dev	OFF	OFF	OFF	OFF	OFF	OFF	OFF		
Average	1	1	1	1	1	1	1	1	
Delay	0 s	0 s	0 s	0 s	0 s	0 s	0 s	0 s	
Equ		Series	Series	Parallel		Series			
Sequence	1	2	3	4	5	6	7	8	9
Switch	ON	ON	ON	ON	ON	ON	ON	ON	ON

Lx	Pins	Std(H)	Low	High	Bias	Freq(Hz)	Level	Q-STD	Q-Low	Q-High
0	P01-P02									
1	P11-P12									
2	P21-P22									
3	P31-P32									
4	P11-P22									
5	P11-P12									
6										
7										
8										
9										

7.11.3.1 Lx Limit Setup

The Lx limit setting table is used to set the Lx standard value, upper and lower limits, bias,

multi-frequency, multi-level, Q standard value and Q upper and lower limits of each transformer winding.

Touch the Lx limit setting table, or move the cursor to the Lx limit setting area, and use the number keys, the corresponding magnification or the [ENTER] key to set.

The magnification corresponding to Lx is p, n, μ , m, and the [ENTER] key is x1.

Trans Condition										Home
	Turn	Lx	Lk	Cx	Zx	ACR	DCR	PS	BAL	
Freq(Hz)	10.0000k	10.0000k	10.0000k	10.0000k	10.0000k	10.0000k				
Level	1 V	300mV	300mV	300mV	300mV	300mV	2 V	2 V		
Dev	OFF	$\Delta\%$	OFF	OFF	OFF	OFF	OFF			
Average	1	1	1	1	1	1	1	1		
Delay	0 s	0 s	0 s	0 s	0 s	0 s	0 s	0 s		
Equ		Series	Series	Parallel		Series				
Sequence	1	2	3	4	5	6	7	8	9	
Switch	ON	ON	ON	ON	ON	ON	ON	ON	ON	ON

Lx	Pins	Std(H)	Low	High	Bias	Freq(Hz)	Level	Q-STD	Q-Low	Q-High
0	P01-P02	1.0000m	-5.0000	5.0000						
1	P11-P12	300.00 μ	-5.0000	5.0000						
2	P21-P22	300.00 μ	-5.0000	5.0000						
3	P31-P32	220.00 μ	-5.0000	5.0000						
4	P11-P22	1.0000m	-5.0000	5.0000						
5	P11-P12	300.00 μ	-5.0000	5.0000						
6										
7										
8										
9										

2021/12/16 14:24:56

7.11.3.2 Add DC Bias to Lx

The instrument can use a built-in DC bias source of 100mA or 2A. When setting the current value, the user can set a maximum value of 2A for the sake of compatibility of storage files.

Trans Condition										Home
	Turn	Lx	Lk	Cx	Zx	ACR	DCR	PS	BAL	
Freq(Hz)	10.0000k	10.0000k	10.0000k	10.0000k	10.0000k	10.0000k				
Level	1 V	300mV	300mV	300mV	300mV	300mV	2 V	2 V		
Dev	OFF	$\Delta\%$	OFF	OFF	OFF	OFF	OFF			
Average	1	1	1	1	1	1	1	1		
Delay	0 s	0 s	0 s	0 s	0 s	0 s	0 s	0 s		
Equ		Series	Series	Parallel		Series				
Sequence	1	2	3	4	5	6	7	8	9	
Switch	ON	ON	ON	ON	ON	ON	ON	ON	ON	ON

Lx	Pins	Std(H)	Low	High	Bias	Freq(Hz)	Level	Q-STD	Q-Low	Q-High
0	P01-P02	1.0000m	-5.0000	5.0000	8mA					
1	P11-P12	300.00 μ	-5.0000	5.0000						
2	P21-P22	300.00 μ	-5.0000	5.0000						
3	P31-P32	220.00 μ	-5.0000	5.0000	8mA					
4	P11-P22	1.0000m	-5.0000	5.0000						
5	P11-P12	300.00 μ	-5.0000	5.0000						
6										
7										
8										
9										

2021/12/16 14:25:23

7.11.3.3 Lx Multi-frequency Setup

If the user needs to use different frequencies to test different Lx pins of the transformer, in the transformer Lx limit setting table, touch or move the cursor to the Lx frequency area. After inputting the frequency in this area, the frequency here will be automatically used during the test. If the parameter is not set, the frequency of Lx in the test condition table will be used.

Trans Condition										Home
	Turn	Lx	Lk	Cx	Zx	ACR	DCR	PS	BAL	
Freq(Hz)	10.0000k	10.0000k	10.0000k	10.0000k	10.0000k	10.0000k				
Level	1 V	300mV	300mV	300mV	300mV	300mV	2 V	2 V		
Dev	OFF	Δ%	OFF	OFF	OFF	OFF	OFF			
Average	1	1	1	1	1	1	1	1		
Delay	0 s	0 s	0 s	0 s	0 s	0 s	0 s	0 s		
Equ		Series	Series	Parallel		Series				
Sequence	1	2	3	4	5	6	7	8	9	
Switch	ON	ON	ON	ON	ON	ON	ON	ON	ON	

Lx	Pins	Std(H)	Low	High	Bias	Freq(Hz)	Level	Q-STD	Q-Low	Q-High
0	P01-P02	1.0000m	-5.0000	5.0000	8mA					
1	P11-P12	300.00μ	-5.0000	5.0000						
2	P21-P22	300.00μ	-5.0000	5.0000						
3	P31-P32	220.00μ	-5.0000	5.0000	8mA					
4	P11-P22	1.0000m	-5.0000	5.0000						
5	P11-P12	300.00μ	-5.0000	5.0000		20.0000k				
6										
7										
8										
9										

2021/12/16 14:25:45

7.11.3.4 Lx Multi-level Setup

If the user needs to use different levels to test different Lx pins of the transformer, in the transformer Lx limit setting table, touch or move the cursor to the Lx level area. After inputting the level in this area, the test will automatically use here. If the parameter is not set, the Lx level in the test condition table will be used.

Trans Condition										Home
	Turn	Lx	Lk	Cx	Zx	ACR	DCR	PS	BAL	
Freq(Hz)	10.0000k	10.0000k	10.0000k	10.0000k	10.0000k	10.0000k				
Level	1 V	300mV	300mV	300mV	300mV	300mV	2 V	2 V		
Dev	OFF	Δ%	OFF	OFF	OFF	OFF	OFF			
Average	1	1	1	1	1	1	1	1		
Delay	0 s	0 s	0 s	0 s	0 s	0 s	0 s	0 s		
Equ		Series	Series	Parallel		Series				
Sequence	1	2	3	4	5	6	7	8	9	
Switch	ON	ON	ON	ON	ON	ON	ON	ON	ON	

Lx	Pins	Std(H)	Low	High	Bias	Freq(Hz)	Level	Q-STD	Q-Low	Q-High
0	P01-P02	1.0000m	-5.0000	5.0000	8mA					
1	P11-P12	300.00μ	-5.0000	5.0000			500mV			
2	P21-P22	300.00μ	-5.0000	5.0000						
3	P31-P32	220.00μ	-5.0000	5.0000	8mA					
4	P11-P22	1.0000m	-5.0000	5.0000						
5	P11-P12	300.00μ	-5.0000	5.0000		20.0000k				
6										
7										
8										
9										

2021/12/16 14:26:28

7.11.3.5 Q Limit Setup

On the <Trans Condition> page, touch or move the cursor to the Q-STD, Q-Low and Q-High to set. Note: The Q value test switch is set at the Lx switch.

Trans Condition										Home
	Turn	Lx	Lk	Cx	Zx	ACR	DCR	PS	BAL	
Freq(Hz)	10.0000k	10.0000k	10.0000k	10.0000k	10.0000k	10.0000k				Lx
Level	1 V	300mV	300mV	300mV	300mV	300mV	2 V	2 V		PRI. ↻
Dev	OFF	Δ%	OFF	OFF	OFF	OFF	OFF	OFF		A1
Average	1	1	1	1	1	1	1	1		Clear Lx Table
Delay	0 s	0 s	0 s	0 s	0 s	0 s	0 s	0 s		Copy ↓ ↓
Equ		Series	Series	Parallel		Series				
Sequence	1	2	3	4	5	6	7	8	9	
Switch	ON	ON	ON	ON	ON	ON	ON	ON	ON	

Lx	Pins	Std(H)	Low	High	Bias	Freq(Hz)	Level	Q-STD	Q-Low	Q-High
0	P01-P02	1.0000m	-5.0000	5.0000	8mA			10.000	9.0000	
1	P11-P12	300.00μ	-5.0000	5.0000			500mV	10.000	9.0000	
2	P21-P22	300.00μ	-5.0000	5.0000				10.000	9.0000	
3	P31-P32	220.00μ	-5.0000	5.0000	8mA			10.000	9.0000	
4	P11-P22	1.0000m	-5.0000	5.0000						
5	P11-P12	300.00μ	-5.0000	5.0000		20.0000k				
6										
7										
8										
9										

7.11.4 Lk Test Conditions Setup

On the <Trans Condition> page, touch or move the cursor to the Lk column of the test condition table to set the Lk parameters.

Trans Condition										Home
	Turn	Lx	Lk	Cx	Zx	ACR	DCR	PS	BAL	
Freq(Hz)	10.0000k	10.0000k	10.0000k	10.0000k	10.0000k	10.0000k				Lk
Level	1 V	300mV	300mV	300mV	300mV	300mV	2 V	2 V		PRI. ↻
Dev	OFF	Δ%	OFF	OFF	OFF	OFF	OFF	OFF		A1
Average	1	1	1	1	1	1	1	1		Clear Lk Table
Delay	0 s	0 s	0 s	0 s	0 s	0 s	0 s	0 s		Copy ↓ ↓
Equ		Series	Series	Parallel		Series				
Sequence	1	2	3	4	5	6	7	8	9	
Switch	ON	ON	ON	ON	ON	ON	ON	ON	ON	

Lk	Pins	Std(H)	Low	High	Freq(Hz)	Level	Short Pins
0	P01-P02	10.000μ	0.0010μ	12.000μ			
1	P11-P12						
2	P21-P22						
3	P31-P32						
4	P11-P22						
5	P11-P12						
6							
7							
8							
9							

7.11.4.1 Lk Limit Setup

The Lk limit setting table is used to set the Lk standard value, upper and lower limits, multi-frequency, multi-level, and short-circuit pins of each winding of the transformer.

Touch the Lk limit setting table, or move the cursor to the Lk limit setting area, and use the number keys, the corresponding magnification or the [ENTER] key to set.

The magnification corresponding to Lk is p, n, μ, m, and the [ENTER] key is x1.

Trans Condition										Home	
	Turn	Lx	Lk	Cx	Zx	ACR	DCR	PS	BAL		Lk
Freq(Hz)	10.0000k	10.0000k	10.0000k	10.0000k	10.0000k	10.0000k					
Level	1 V	300mV	300mV	300mV	300mV	300mV	2 V	2 V			
Dev	OFF	Δ%	OFF	OFF	OFF	OFF	OFF	OFF			
Average	1	1	1	1	1	1	1	1			
Delay	0 s	0 s	0 s	0 s	0 s	0 s	0 s	0 s			
Equ		Series	Series	Parallel		Series					
Sequence	1	2	3	4	5	6	7	8	9		
Switch	ON	ON	ON	ON	ON	ON	ON	ON	ON		

Lk	Pins	Std(H)	Low	High	Freq(Hz)	Level	Short Pins
0	P01-P02	10.000μ	0.0010μ	12.000μ			
1	P11-P12						
2	P21-P22						
3	P31-P32						
4	P11-P22						
5	P11-P12						
6							
7							
8							
9							

2021/12/16 14:27:47

7.11.4.2 Lk Multi-frequency Setup

If the user needs to use different frequencies to test different Lk pins of the transformer, in the transformer Lk limit setting table, touch or move the cursor to the frequency area of Lk. After inputting the frequency in this area, the frequency here will be automatically used during the test. If the parameter is not set, the frequency of Lk in the test condition table will be used.

Trans Condition										Home	
	Turn	Lx	Lk	Cx	Zx	ACR	DCR	PS	BAL		Lk
Freq(Hz)	10.0000k	10.0000k	10.0000k	10.0000k	10.0000k	10.0000k					
Level	1 V	300mV	300mV	300mV	300mV	300mV	2 V	2 V			
Dev	OFF	Δ%	OFF	OFF	OFF	OFF	OFF	OFF			
Average	1	1	1	1	1	1	1	1			
Delay	0 s	0 s	0 s	0 s	0 s	0 s	0 s	0 s			
Equ		Series	Series	Parallel		Series					
Sequence	1	2	3	4	5	6	7	8	9		
Switch	ON	ON	ON	ON	ON	ON	ON	ON	ON		

Lk	Pins	Std(H)	Low	High	Freq(Hz)	Level	Short Pins
0	P01-P02	10.000μ	0.0010μ	12.000μ	20.000k		
1	P11-P12						
2	P21-P22	10.000μ	0.0010μ	12.000μ			
3	P31-P32						
4	P11-P22						
5	P11-P12						
6							
7							
8							
9							

2021/12/16 14:29:03

7.11.4.3 Lx multi-level Setup

If the user needs to use different levels to test different Lk pins of the transformer, in the transformer Lk limit setting table, touch or move the cursor to the Lk level area. After inputting the level in this area, the test will automatically use here. If the parameter is not set, the level of Lk in the test condition table will be used.

Trans Condition										Lk
Turn	Lx	Lk	Cx	Zx	ACR	DCR	PS	BAL		
Freq(Hz)	10.0000k	10.0000k	10.0000k	10.0000k	10.0000k	10.0000k				
Level	1 V	300mV	300mV	300mV	300mV	300mV	2 V	2 V		
Dev	OFF	Δ%	OFF	OFF	OFF	OFF	OFF	OFF		
Average	1	1	1	1	1	1	1	1		
Delay	0 s	0 s	0 s	0 s	0 s	0 s	0 s	0 s		
Equ		Series	Series	Parallel		Series				
Sequence	1	2	3	4	5	6	7	8	9	
Switch	ON	ON	ON	ON	ON	ON	ON	ON	ON	

Lk	Pins	Std(H)	Low	High	Freq(Hz)	Level	Short Pins
0	P01-P02	10.000μ	0.0010μ	12.000μ	20.0000k		
1	P11-P12						
2	P21-P22	10.000μ	0.0010μ	12.000μ		500mV	
3	P31-P32						
4	P11-P22						
5	P11-P12						
6							
7							
8							
9							

7.11.4.4 Lk Turn-Ratio Short Pins

When setting the leakage inductance short pins, you can use the soft key. and ~ to input multiple pins, the maximum number of pins can be saved here is 48.

Example:

1: Input a discontinuous number "1, 3, 5, 7, 9" and use the soft key. to separate each number, press ENTER to confirm, the final data displayed in the table is (1, 3, 5, 7, 9).

2: Input a continuous number of "1,2,3,4,5,6,7,8,9", first input the number "1", then press the soft key ~, finally input "9", press the ENTER key to confirm After that, the data finally displayed in the table is (1~9).

Note: The maximum supported number of leakage inductance short pins is 48, and the latter part of the pins will be ignored.

3: Input part of continuous numbers and non-continuous numbers "1,2,3,4,5,7,9", the continuous part is the same as step 2, the discontinuous part is the same as step 1, press ENTER to confirm, and finally displayed in the table The data is (1~5,7,9).

Trans Condition										Lk
Turn	Lx	Lk	Cx	Zx	ACR	DCR	PS	BAL		
Freq(Hz)	10.0000k	10.0000k	10.0000k	10.0000k	10.0000k	10.0000k				
Level	1 V	300mV	300mV	300mV	300mV	300mV	2 V	2 V		
Dev	OFF	Δ%	OFF	OFF	OFF	OFF	OFF	OFF		
Average	1	1	1	1	1	1	1	1		
Delay	0 s	0 s	0 s	0 s	0 s	0 s	0 s	0 s		
Equ		Series	Series	Parallel		Series				
Sequence	1	2	3	4	5	6	7	8	9	
Switch	ON	ON	ON	ON	ON	ON	ON	ON	ON	

Lk	Pins	Std(H)	Low	High	Freq(Hz)	Level	Short Pins
0	P01-P02	10.000μ	0.0010μ	12.000μ	20.0000k		P11-P12
1	P11-P12						
2	P21-P22	10.000μ	0.0010μ	12.000μ		500mV	P01-P12,P32-P31
3	P31-P32						
4	P11-P22						
5	P11-P12						
6							
7							
8							
9							

7.11.5 Cx Test Conditions Setup

On the <Trans Condition> page, touch or move the cursor to the Cx column of the test condition

table to set the Cx parameters.

Trans Condition									
	Turn	Lx	Lk	Cx	Zx	ACR	DCR	PS	BAL
Freq(Hz)	10.0000k	10.0000k	10.0000k	10.0000k	10.0000k	10.0000k			
Level	1 V	300mV	300mV	300mV	300mV	300mV	2 V	2 V	
Dev	OFF	Δ%	OFF	OFF	OFF	OFF	OFF	OFF	
Average	1	1	1	1	1	1	1	1	
Delay	0 s	0 s	0 s	0 s	0 s	0 s	0 s	0 s	
Equ		Series	Series	Parallel		Series			
Sequence	1	2	3	4	5	6	7	8	9
Switch	ON	ON	ON	ON	ON	ON	ON	ON	ON

Cx	Pins(+)	Pins(-)	Short Pins	Std(F)	Low	High	Freq(Hz)
0							
1							
2							
3							
4							
5							
6							
7							
8							
9							

7.11.5.1 Cx Limit Setup

The following figure shows the example transformer. Test the capacitance between two turns: Np1 and Np2.

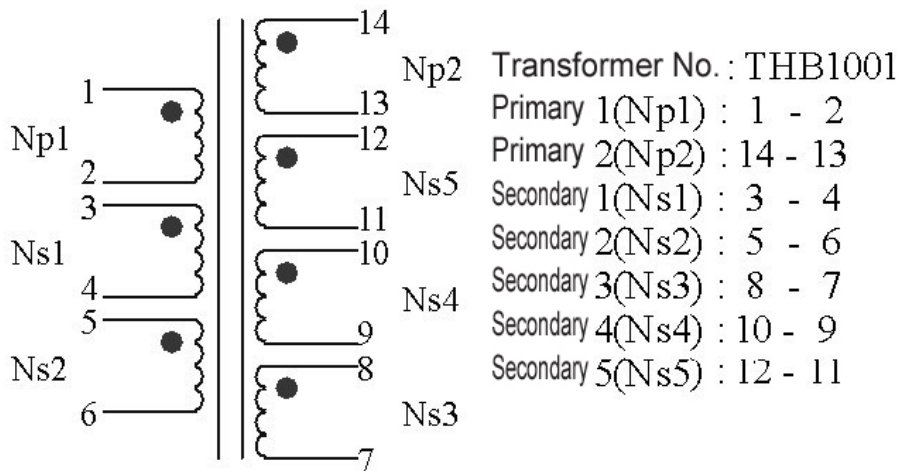

The Cx limit setting table is used to set the positive and negative pins of Cx, short pins, nominal value, upper and lower limit, multi-frequency, multi-level, and D value limit.

Due to the large number of table parameters, one page cannot display all the setting parameters. Here, you can move the cursor left and right, or directly swipe the limit setting table on the screen to display the incomplete parameter settings.

Touch the Cx limit setting table, or move the cursor to the Cx limit setting area, and use the numeric keys, corresponding magnification or [ENTER] key to set.

The magnification corresponding to Cx is p,n,μ,m, and the [ENTER] key is x1.

Trans Condition									
	Turn	Lx	Lk	Cx	Zx	ACR	DCR	PS	BAL
Freq(Hz)	10.0000k	10.0000k	10.0000k	10.0000k	10.0000k	10.0000k			
Level	1 V	300mV	300mV	300mV	300mV	300mV	2 V	2 V	
Dev	OFF	Δ%	OFF	OFF	OFF	OFF	OFF		
Average	1	1	1	1	1	1	1	1	
Delay	0 s	0 s	0 s	0 s	0 s	0 s	0 s	0 s	
Equ		Series	Series	Parallel		Series			
Sequence	1	2	3	4	5	6	7	8	9
Switch	ON	ON	ON	ON	ON	ON	ON	ON	ON

Cx	Short Pins	Std(F)	Low	High	Freq(Hz)	Level	D-Std	D-Low	D-High
0		10.000p	8.0000p	12.000p					
1									
2									
3									
4									
5									
6									
7									
8									
9									

7.11.5.2 Cx Pin(+), Pin(-) and Short Pins

When setting the Cx short pins, you can use the soft key . and ~ to input multiple pins, where a maximum of 24 pins can be saved.

Example:

1: Input a segment of discontinuous numbers "1, 3, 5, 7, 9", use the soft key . to separate each number, press the ENTER key to confirm, the final data displayed in the table is (1, 3, 5, 7, 9).

2: Input a continuous number of "1, 2, 3, 4, 5, 6, 7, 8, 9", first input the number "1", then press the soft key ~, and finally input "9", press the ENTER key to confirm. After that, the data finally displayed in the table is (1~9).

Note: The maximum number of Cx pins and short pins supported is 24, and the excess pins will be ignored.

3: Input part of consecutive numbers and non-consecutive numbers "1, 2, 3, 4, 5, 7, 9", the continuous part is the same as step 2, the non-consecutive part is the same as step 1, press the ENTER key to confirm, and finally display in the table The data is (1~5, 7, 9).

Trans Condition									
	Turn	Lx	Lk	Cx	Zx	ACR	DCR	PS	BAL
Freq(Hz)	10.0000k	10.0000k	10.0000k	10.0000k	10.0000k	10.0000k			
Level	1 V	300mV	300mV	300mV	300mV	300mV	2 V	2 V	
Dev	OFF	Δ%	OFF	OFF	OFF	OFF	OFF		
Average	1	1	1	1	1	1	1	1	
Delay	0 s	0 s	0 s	0 s	0 s	0 s	0 s	0 s	
Equ		Series	Series	Parallel		Series			
Sequence	1	2	3	4	5	6	7	8	9
Switch	ON	ON	ON	ON	ON	ON	ON	ON	ON

Cx	Pins(+)	Pins(-)	Short Pins	Std(F)	Low	High	Freq(Hz)
0	P01~P02	P62~P61		10.000p	8.0000p	12.000p	
1							
2							
3							
4							
5							
6							
7							
8							
9							

7.11.5.3 Cx Multi-frequency Setup

If the user needs to use different frequencies to test different Cx pins of the transformer, in the transformer Cx limit setting table, touch or move the cursor to the frequency area of Cx, after

inputting the frequency in this area, the frequency here will be used automatically during the test. If the parameter is not set, the frequency of Cx in the test condition table will be used.

Trans Condition											Cx									
Freq(Hz)	10.0000k	10.0000k	10.0000k	10.0000k	10.0000k	10.0000k	10.0000k	10.0000k												
Level	1 V	300mV	300mV	300mV	300mV	300mV	300mV	2 V	2 V											
Dev	OFF	Δ%	OFF	OFF	OFF	OFF	OFF	OFF	OFF											
Average	1	1	1	1	1	1	1	1	1											
Delay	0 s	0 s	0 s	0 s	0 s	0 s	0 s	0 s	0 s											
Equ		Series	Series	Parallel		Series														
Sequence	1	2	3	4	5	6	7	8	9											
Switch	ON	ON	ON	ON	ON	ON	ON	ON	ON											

Cx	Pins(+)	Pins(-)	Short Pins	Std(F)	Low	High	Freq(Hz)
0	P01-P02	P62-P61		10.000p	8.0000p	12.000p	
1	P11-P12	P52-P51		10.000p	8.0000p	12.000p	12.0000k
2							
3							
4							
5							
6							
7							
8							
9							

7.11.5.4 Cx Multi-level Setup

If the user needs to use different levels to test different Cx pins of the transformer, in the transformer Cx limit setting table, touch or move the cursor to the level area of Cx, after inputting the level in this area, it will be used automatically during the test. If the parameter is not set, the level of Cx in the test condition table will be used.

Trans Condition											Cx									
Freq(Hz)	10.0000k	10.0000k	10.0000k	10.0000k	10.0000k	10.0000k	10.0000k	10.0000k												
Level	1 V	300mV	300mV	300mV	300mV	300mV	300mV	2 V	2 V											
Dev	OFF	Δ%	OFF	OFF	OFF	OFF	OFF	OFF	OFF											
Average	1	1	1	1	1	1	1	1	1											
Delay	0 s	0 s	0 s	0 s	0 s	0 s	0 s	0 s	0 s											
Equ		Series	Series	Parallel		Series														
Sequence	1	2	3	4	5	6	7	8	9											
Switch	ON	ON	ON	ON	ON	ON	ON	ON	ON											

Cx	Short Pins	Std(F)	Low	High	Freq(Hz)	Level	D-Std	D-Low	D-High
0		10.000p	8.0000p	12.000p					
1		10.000p	8.0000p	12.000p	12.0000k	500mV			
2									
3									
4									
5									
6									
7									
8									
9									

7.11.5.5 D Limit Setup

In the transformer Cx limit setting table, touch or move the cursor to D-Std, D-Low and D-High of Cx to set.

NOTE: The D value test switch is set at the Cx switch.

Trans Condition										C _x	
Freq(Hz)	10.0000k	10.0000k	10.0000k	10.0000k	10.0000k	10.0000k	10.0000k	2 V	2 V		PRI. A1
Level	1 V	300mV	300mV	300mV	300mV	300mV	2 V	2 V			Clear C _x Table
Dev	OFF	Δ%	OFF	OFF	OFF	OFF	OFF	OFF			Copy ↓ ↓
Average	1	1	1	1	1	1	1	1			
Delay	0 s	0 s	0 s	0 s	0 s	0 s	0 s	0 s			
Equ		Series	Series	Parallel		Series					
Sequence	1	2	3	4	5	6	7	8	9		
Switch	ON	ON	ON	ON	ON	ON	ON	ON	ON		

C _x	Short Pins	Std(F)	Low	High	Freq(Hz)	Level	D-Std	D-Low	D-High
0		10.000p	8.0000p	12.000p					
1		10.000p	8.0000p	12.000p	12.0000k	500mV	2.0000m		5.0000m
2									
3									
4									
5									
6									
7									
8									
9									

7.11.6 Z_x Test Conditions Setup

On the <Trans Condition> page of the transformer scan, touch or move the cursor to a column of Z_x in the test condition to set the Z_x parameters.

Trans Condition										Z _x	
Freq(Hz)	10.0000k	10.0000k	10.0000k	10.0000k	10.0000k	10.0000k	10.0000k	2 V	2 V		PRI. A1
Level	1 V	300mV	300mV	300mV	300mV	300mV	300mV	2 V	2 V		Clear C _x Table
Dev	OFF	Δ%	OFF	OFF	OFF	OFF	OFF	OFF			Copy ↓ ↓
Average	1	1	1	1	1	1	1	1			
Delay	0 s	0 s	0 s	0 s	0 s	0 s	0 s	0 s			
Equ		Series	Series	Parallel		Series					
Sequence	1	2	3	4	5	6	7	8	9		
Switch	ON	ON	ON	ON	ON	ON	ON	ON	ON		

Z _x	Pins	Std(D)	Low	High	Bias	Freq(Hz)	Level	Short Pins
0	P01-P02							
1	P11-P12							
2	P21-P22							
3	P31-P32							
4	P11-P22							
5	P11-P12							
6								
7								
8								
9								

7.11.6.1 Z_x Limit Setup

The Z_x limit setting table is used to set the Z_x standard value, upper and lower limit, bias, multi-frequency and multi-level.

Touch the Z_x limit setting table, or move the cursor to the Z_x limit setting area, and use the numeric keys, corresponding magnification or [ENTER] key to set.

The magnification corresponding to L_k is M, k, μ, m, and the [ENTER] key is x1.

Trans Condition									
	Turn	Lx	Lk	Cx	Zx	ACR	DCR	PS	BAL
Freq(Hz)	10.0000k	10.0000k	10.0000k	10.0000k	10.0000k	10.0000k			
Level	1 V	300mV	300mV	300mV	300mV	300mV	2 V	2 V	
Dev	OFF	Δ%	OFF	OFF	OFF	OFF	OFF		
Average	1	1	1	1	1	1	1	1	
Delay	0 s	0 s	0 s	0 s	0 s	0 s	0 s	0 s	
Equ		Series	Series	Parallel		Series			
Sequence	1	2	3	4	5	6	7	8	9
Switch	ON	ON	ON	ON	ON	ON	ON	ON	ON

Zx	Pins	Std(Q)	Low	High	Bias	Freq(Hz)	Level	Short Pins
0	P01-P02	628.00	600.00	800.00				
1	P11-P12							
2	P21-P22							
3	P31-P32							
4	P11-P22							
5	P11-P12	300.00	280.00	320.00				
6								
7								
8								
9								

7.11.6.2 Add DC Bias to Zx

The instrument can use a built-in DC bias current source of 100mA or 2A. When setting the current value, the user can set a maximum value of 2A for the sake of compatibility with the storage file.

Trans Condition									
	Turn	Lx	Lk	Cx	Zx	ACR	DCR	PS	BAL
Freq(Hz)	10.0000k	10.0000k	10.0000k	10.0000k	10.0000k	10.0000k			
Level	1 V	300mV	300mV	300mV	300mV	300mV	2 V	2 V	
Dev	OFF	Δ%	OFF	OFF	OFF	OFF	OFF		
Average	1	1	1	1	1	1	1	1	
Delay	0 s	0 s	0 s	0 s	0 s	0 s	0 s	0 s	
Equ		Series	Series	Parallel		Series			
Sequence	1	2	3	4	5	6	7	8	9
Switch	ON	ON	ON	ON	ON	ON	ON	ON	ON

Zx	Pins	Std(Q)	Low	High	Bias	Freq(Hz)	Level	Short Pins
0	P01-P02	628.00	600.00	800.00	8mA			
1	P11-P12							
2	P21-P22							
3	P31-P32							
4	P11-P22							
5	P11-P12	300.00	280.00	320.00				
6								
7								
8								
9								

7.11.6.3 Zx Multi-frequency Setup

If the user needs to use different frequencies to test different Zx pins of the transformer, in the transformer Zx limit setting table, touch or move the cursor to the frequency area of Zx, after inputting the frequency in this area, the frequency here will be used automatically during the test. If the parameter is not set, the frequency of Zx in the test condition table will be used.

Trans Condition										Zx
	Turn	Lx	Lk	Cx	Zx	ACR	DCR	PS	BAL	
Freq(Hz)	10.0000k	10.0000k	10.0000k	10.0000k	10.0000k	10.0000k				
Level	1 V	300mV	300mV	300mV	300mV	300mV	2 V	2 V		
Dev	OFF	Δ%	OFF	OFF	OFF	OFF	OFF			
Average	1	1	1	1	1	1	1	1		
Delay	0 s	0 s	0 s	0 s	0 s	0 s	0 s	0 s		
Equ		Series	Series	Parallel		Series				
Sequence	1	2	3	4	5	6	7	8	9	
Switch	ON	ON	ON	ON	ON	ON	ON	ON	ON	

Zx	Pins	Std(Ω)	Low	High	Bias	Freq(Hz)	Level	Short Pins
0	P01-P02	628.00	600.00	800.00	8mA			
1	P11-P12							
2	P21-P22							
3	P31-P32							
4	P11-P22							
5	P11-P12	300.00	280.00	320.00		5.00000k		
6								
7								
8								
9								

7.11.6.4 Zx Multi-level Setup

If the user needs to use different levels to test different Zx pins of the transformer, in the transformer Zx limit setting table, touch or move the cursor to the level area of Zx, after inputting the level in this area, it will be used automatically during the test. If the parameter is not set, the level of Zx in the test condition table will be used.

Trans Condition										Zx
	Turn	Lx	Lk	Cx	Zx	ACR	DCR	PS	BAL	
Freq(Hz)	10.0000k	10.0000k	10.0000k	10.0000k	10.0000k	10.0000k				
Level	1 V	300mV	300mV	300mV	300mV	300mV	2 V	2 V		
Dev	OFF	Δ%	OFF	OFF	OFF	OFF	OFF			
Average	1	1	1	1	1	1	1	1		
Delay	0 s	0 s	0 s	0 s	0 s	0 s	0 s	0 s		
Equ		Series	Series	Parallel		Series				
Sequence	1	2	3	4	5	6	7	8	9	
Switch	ON	ON	ON	ON	ON	ON	ON	ON	ON	

Zx	Pins	Std(Ω)	Low	High	Bias	Freq(Hz)	Level	Short Pins
0	P01-P02	628.00	600.00	800.00	8mA			
1	P11-P12							
2	P21-P22							
3	P31-P32							
4	P11-P22							
5	P11-P12	300.00	280.00	320.00		5.00000k	500mV	
6								
7								
8								
9								

7.11.7 ACR Test Conditions Setup

On the <Trans Condition> page of the transformer scan, touch or move the cursor to a column of ACR in the test condition table to set the ACR parameters.

Trans Condition										
	Turn	Lx	Lk	Cx	Zx	ACR	DCR	PS	BAL	
Freq(Hz)	10.0000k	10.0000k	10.0000k	10.0000k	10.0000k	10.0000k				
Level	1 V	300mV	300mV	300mV	300mV	300mV	2 V	2 V		
Dev	OFF	Δ%	OFF	OFF	OFF	OFF	OFF			
Average	1	1	1	1	1	1	1	1		
Delay	0 s	0 s	0 s	0 s	0 s	0 s	0 s	0 s		
Equ		Series	Series	Parallel		Series				
Sequence	1	2	3	4	5	6	7	8	9	
Switch	ON	ON	ON	ON	ON	ON	ON	ON	ON	

ACr	Pins	Std(Ω)	Low	High	Freq(Hz)	Level
0	P01-P02					
1	P11-P12					
2	P21-P22					
3	P31-P32					
4	P11-P22					
5	P11-P12					
6						
7						
8						
9						

7.11.7.1 ACR Limit Setup

The ACR limit setting table is used to set the standard value, upper and lower limit, multi-frequency and multi-level of ACR.

Touch the ACR limit setting table, or move the cursor to the ACR limit setting area, and use the numeric keys, corresponding magnification or [ENTER] key to set.

The magnification corresponding to ACR is M, k, μ, m, and the [ENTER] key is x1.

Trans Condition										
	Turn	Lx	Lk	Cx	Zx	ACR	DCR	PS	BAL	
Freq(Hz)	10.0000k	10.0000k	10.0000k	10.0000k	10.0000k	10.0000k				
Level	1 V	300mV	300mV	300mV	300mV	300mV	2 V	2 V		
Dev	OFF	Δ%	OFF	OFF	OFF	OFF	OFF			
Average	1	1	1	1	1	1	1	1		
Delay	0 s	0 s	0 s	0 s	0 s	0 s	0 s	0 s		
Equ		Series	Series	Parallel		Series				
Sequence	1	2	3	4	5	6	7	8	9	
Switch	ON	ON	ON	ON	ON	ON	ON	ON	ON	

ACr	Pins	Std(Ω)	Low	High	Freq(Hz)	Level
0	P01-P02	11.000	10.000	12.000		
1	P11-P12					
2	P21-P22					
3	P31-P32					
4	P11-P22					
5	P11-P12	6.0000	5.0000	10.000		
6						
7						
8						
9						

7.11.7.2 ACR Multi-frequency Setup

If the user needs to use different frequencies to test different ACR pins of the transformer, in the transformer ACR limit setting table, touch or move the cursor to the frequency area of ACR, after inputting the frequency in this area, the frequency here will be used automatically during the test. If the parameter is not set, the frequency of the ACR in the test condition table will be used.

Trans Condition											ACR	
Freq(Hz)	10.0000k	10.0000k	10.0000k	10.0000k	10.0000k	10.0000k	10.0000k	DCR	PS	BAL		PRI. A1
Level	1 V	300mV	300mV	300mV	300mV	300mV	300mV	2 V	2 V			Clear ACR Table
Dev	OFF	Δ%	OFF	OFF	OFF	OFF	OFF	OFF				Copy ↓ ↓
Average	1	1	1	1	1	1	1	1	1			
Delay	0 s	0 s	0 s	0 s	0 s	0 s	0 s	0 s	0 s			
Equ		Series	Series	Parallel	Series							
Sequence	1	2	3	4	5	6	7	8	9			
Switch	ON	ON	ON	ON	ON	ON	ON	ON	ON	ON		
ACr	Pins	Std(Q)	Low	High	Freq(Hz)	Level						
0	P01-P02	11.000	10.000	12.000								
1	P11-P12											
2	P21-P22											
3	P31-P32											
4	P11-P22											
5	P11-P12	6.0000	5.0000	10.000	5.0000k							
6												
7												
8												
9												

7.11.7.3 ACR Multi-level Setup

If the user needs to use different levels to test different ACR pins of the transformer, in the transformer ACR limit setting table, touch or move the cursor to the ACR level area, after inputting the level in this area, it will be used automatically during the test. If the parameter is not set, the ACR level in the test condition table will be used.

Trans Condition											ACR	
Freq(Hz)	10.0000k	10.0000k	10.0000k	10.0000k	10.0000k	10.0000k	10.0000k	DCR	PS	BAL		PRI. A1
Level	1 V	300mV	300mV	300mV	300mV	300mV	300mV	2 V	2 V			Clear ACR Table
Dev	OFF	Δ%	OFF	OFF	OFF	OFF	OFF	OFF				Copy ↓ ↓
Average	1	1	1	1	1	1	1	1	1			
Delay	0 s	0 s	0 s	0 s	0 s	0 s	0 s	0 s	0 s			
Equ		Series	Series	Parallel	Series							
Sequence	1	2	3	4	5	6	7	8	9			
Switch	ON	ON	ON	ON	ON	ON	ON	ON	ON	ON		
ACr	Pins	Std(Q)	Low	High	Freq(Hz)	Level						
0	P01-P02	11.000	10.000	12.000								
1	P11-P12											
2	P21-P22											
3	P31-P32											
4	P11-P22											
5	P11-P12	6.0000	5.0000	10.000	5.0000k	500mV						
6												
7												
8												
9												

7.11.8 DCR Test Conditions Setup

On the <Trans Condition> page of the transformer scan, touch or move the cursor to a column of DCR in the test condition table to set DCR parameters.

Trans Condition										
	Turn	Lx	Lk	Cx	Zx	ACR	DCR	PS	BAL	
Freq(Hz)	10.0000k	10.0000k	10.0000k	10.0000k	10.0000k	10.0000k	10.0000k			
Level	1 V	300mV	300mV	300mV	300mV	300mV	2 V	2 V		
Dev	OFF	Δ%	OFF	OFF	OFF	OFF	OFF			
Average	1	1	1	1	1	1	1	1		
Delay	0 s	0 s	0 s	0 s	0 s	0 s	0 s	0 s		
Equ		Series	Series	Parallel		Series				
Sequence	1	2	3	4	5	6	7	8	9	
Switch	ON	ON	ON	ON	ON	ON	ON	ON	ON	

Dcr	Pins	Std(Ω)	Low	High
0	P01-P02			
1	P11-P12			
2	P21-P22			
3	P31-P32			
4	P11-P22			
5	P11-P12			
6				
7				
8				
9				

7.11.8.1 DCR Limit Setup

The DCR limit setting table is used to set the standard value, upper and lower limit of DCR.

Touch the DCR limit setting table, or move the cursor to the DCR limit setting area, and use the numeric keys, corresponding magnification or [ENTER] key to set.

The magnification corresponding to DCR is M, k, μ, m, and the [ENTER] key is x1.

Trans Condition										
	Turn	Lx	Lk	Cx	Zx	ACR	DCR	PS	BAL	
Freq(Hz)	10.0000k	10.0000k	10.0000k	10.0000k	10.0000k	10.0000k	10.0000k			
Level	1 V	300mV	300mV	300mV	300mV	300mV	2 V	2 V		
Dev	OFF	Δ%	OFF	OFF	OFF	OFF	OFF			
Average	1	1	1	1	1	1	1	1		
Delay	0 s	0 s	0 s	0 s	0 s	0 s	0 s	0 s		
Equ		Series	Series	Parallel		Series				
Sequence	1	2	3	4	5	6	7	8	9	
Switch	ON	ON	ON	ON	ON	ON	ON	ON	ON	

Dcr	Pins	Std(Ω)	Low	High
0	P01-P02	250.00m	240.00m	260.00m
1	P11-P12	110.00m	100.00m	130.00m
2	P21-P22	110.00m	100.00m	130.00m
3	P31-P32	81.00m	70.00m	90.00m
4	P11-P22			
5	P11-P12			
6				
7				
8				
9				

7.11.9 PS Test Conditions Setup

On the <Trans Condition> page of the transformer scan, touch or move the cursor to a column of PS in the test condition table to set PS parameters.

Trans Condition										PS
Freq(Hz)	Turn	Lx	Lk	Cx	Zx	ACR	DCR	PS	BAL	
10.0000k	10.0000k	10.0000k	10.0000k	10.0000k	10.0000k	10.0000k	10.0000k	10.0000k	10.0000k	PS
Level	1 V	300mV	300mV	300mV	300mV	300mV	2 V	2 V		PRI.
Dev	OFF	Δ%	OFF	OFF	OFF	OFF	OFF	OFF		A1
Average	1	1	1	1	1	1	1	1		
Delay	0 s	0 s	0 s	0 s	0 s	0 s	0 s	0 s		
Equ		Series	Series	Parallel		Series				
Sequence	1	2	3	4	5	6	7	8	9	
Switch	ON	ON	ON	ON	ON	ON	ON	ON	ON	

PS	PS +	PS -	Low	High
0			10.000k	
1			10.000k	
2			10.000k	
3			10.000k	
4			10.000k	
5			10.000k	
6			10.000k	
7			10.000k	
8			10.000k	
9			10.000k	

7.11.9.1 PS Limit Setup

The PS limit setting table is used to set the positive and negative pins and upper and lower limits of PS.

Touch the PS limit setting table, or move the cursor to the PS limit setting area, and use the numeric keys, corresponding magnification or [ENTER] key to set.

The magnification corresponding to PS is M, k, μ, m, and the [ENTER] key is x1.

The default lower limit of PS is 10kΩ.

Note: In general testing, the upper limit does not need to be set, that is, there is no upper limit.

Trans Condition										PS
Freq(Hz)	Turn	Lx	Lk	Cx	Zx	ACR	DCR	PS	BAL	
10.0000k	10.0000k	10.0000k	10.0000k	10.0000k	10.0000k	10.0000k	10.0000k	10.0000k	10.0000k	PS
Level	1 V	300mV	300mV	300mV	300mV	300mV	2 V	2 V		PRI.
Dev	OFF	Δ%	OFF	OFF	OFF	OFF	OFF	OFF		A1
Average	1	1	1	1	1	1	1	1		
Delay	0 s	0 s	0 s	0 s	0 s	0 s	0 s	0 s		
Equ		Series	Series	Parallel		Series				
Sequence	1	2	3	4	5	6	7	8	9	
Switch	ON	ON	ON	ON	ON	ON	ON	ON	ON	

PS	PS +	PS -	Low	High
0			10.000k	
1			10.000k	
2			10.000k	
3			10.000k	
4			10.000k	
5			10.000k	
6			10.000k	
7			10.000k	
8			10.000k	
9			10.000k	

7.11.9.2 PS Test Pin Setup

This page is used to set the shorted pins. In the process of auto scanning test, the instrument will test DCR of each set pin and make comparison with the PS low limit set on PS limit setup page.

The following figure shows the example transformer and its setup page of pin short test.

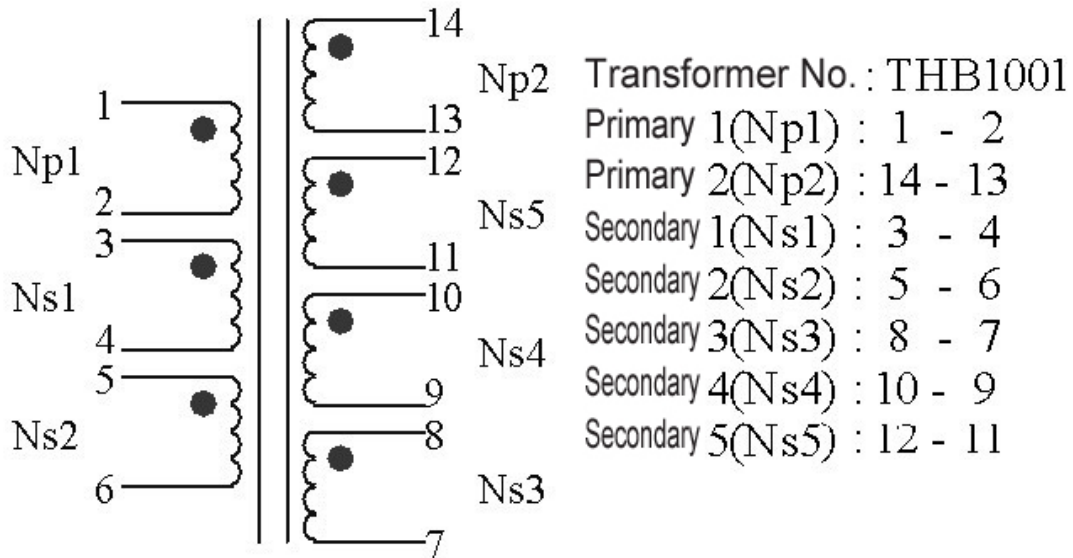

When setting the positive and negative pins of PS, you can use the soft key . and ~ to input multiple pins, where a maximum of 12 pins can be saved.

Example:

1: Input a segment of discontinuous numbers "1, 3, 5, 7, 9", use the soft key . to separate each number, press the ENTER key to confirm, the final data displayed in the table is (1, 3, 5, 7, 9).

2: Input a continuous number "1, 2, 3, 4, 5, 6, 7, 8, 9", first input the number "1", then press the soft key ~, and finally input "9", press the ENTER key to confirm. After that, the data finally displayed in the table is (1~9).

Note: The maximum number of PS positive and negative pins supported is 12, and the excess pins will be ignored.

3: Input part of continuous numbers and non-consecutive numbers "1, 2, 3, 4, 5, 7, 9", the continuous part is the same as step 2, the non-continuous part is the same as step 1, press ENTER key to confirm, and data finally displayed in the table is (1~5, 7, 9).

Trans Condition										PS	
Freq(Hz)	Turn	Lx	Lk	Cx	Zx	ACR	DCR	PS	BAL	PRI.	A1
10.0000k	10.0000k	10.0000k	10.0000k	10.0000k	10.0000k	10.0000k	10.0000k	2 V	2 V		
Level	1 V	300mV	300mV	300mV	300mV	300mV	300mV	2 V	2 V		
Dev	OFF	Δ%	OFF	OFF	OFF	OFF	OFF	OFF	OFF		
Average	1	1	1	1	1	1	1	1	1		
Delay	0 s	0 s	0 s	0 s	0 s	0 s	0 s	0 s	0 s		
Equ		Series	Series	Parallel	Series						
Sequence	1	2	3	4	5	6	7	8	9		
Switch	ON	ON	ON	ON	ON	ON	ON	ON	ON		
PS	PS +		PS -		Low	High					
0	P02		P11		10.000k						
1	P12		P21		10.000k						
2	P31		P42		10.000k						
3	P41		P52		10.000k						
4	P51		P62		10.000k						
5	P01~P02		P52~P51		10.000k						
6					10.000k						
7					10.000k						
8					10.000k						
9					10.000k						

7.11.10 BL Test Conditions Setup

On the <Trans Condition> page of the transformer scan, touch or move the cursor to a column of BAL in the test condition table to set BAL parameters.

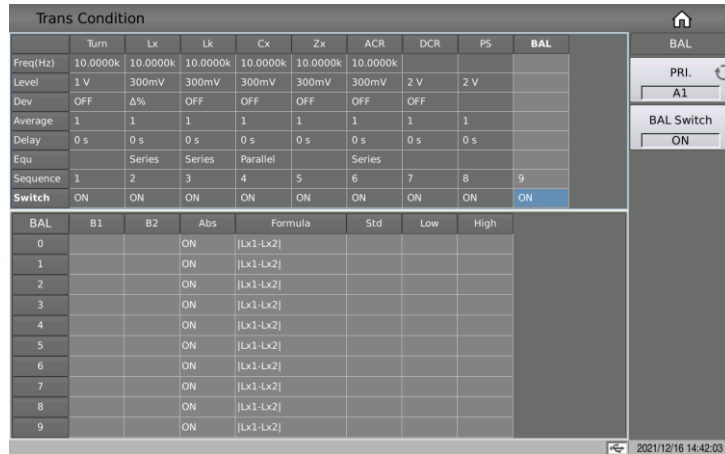

7.11.10.1 BL Test Setup

BAL (balance) is a parameter used to compare the consistency of the two windings of a transformer. BAL upper and lower limits, balance windings, absolute values, and balance formulas can be set. Touch the BAL table, or move the cursor to the BAL test setting area, and use the numeric keys, corresponding magnification or [ENTER] key to set. The magnification corresponding to BAL is p,n,μ,m, and the [ENTER] key is x1.

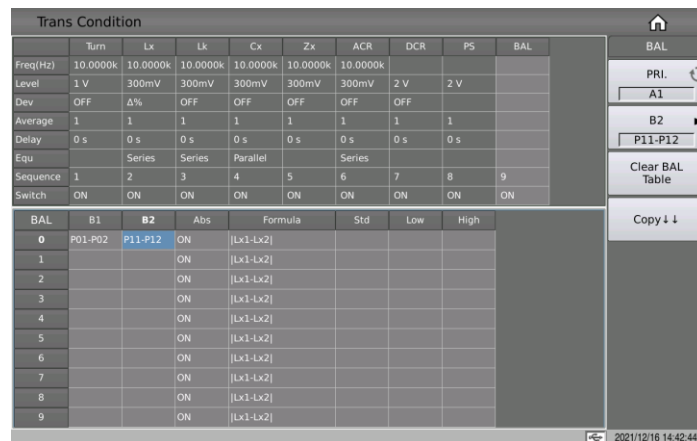

7.11.10.2 BAL Absolute Value Setup

In the formula used to judge the balance of the two windings, to set whether the final result is compared with the absolute value. For example, the formula Lx1-Lx2: When the absolute value switch is ON, the formula will be converted to |Lx1-Lx2|, and the result will be the absolute value of Lx1-Lx2 compared with the set upper and lower limits; When the absolute value switch is OFF, the formula will be converted to Lx1-Lx2, the result will be directly compared with the upper and lower limits set, and the result can be positive or negative.

Trans Condition											Home
	Turn	Lx	Lk	Cx	Zx	ACR	DCR	PS	BAL		BAL
Freq(Hz)	10.0000k	10.0000k	10.0000k	10.0000k	10.0000k	10.0000k					
Level	1 V	300mV	300mV	300mV	300mV	300mV	2 V	2 V			PRI.
Dev	OFF	Δ%	OFF	OFF	OFF	OFF	OFF				A1
Average	1	1	1	1	1	1	1	1			Abs
Delay	0 s	0 s	0 s	0 s	0 s	0 s	0 s	0 s			OFF
Equ		Series	Series	Parallel		Series					Clear BAL Table
Sequence	1	2	3	4	5	6	7	8	9		Copy ↓
Switch	ON	ON	ON	ON	ON	ON	ON	ON	ON		
BAL	B1	B2	Abs	Formula			Std	Low	High		
0	P01-P02	P11-P12	OFF	Lx1-Lx2							
1			ON	Lx1-Lx2							
2			ON	Lx1-Lx2							
3			ON	Lx1-Lx2							
4			ON	Lx1-Lx2							
5			ON	Lx1-Lx2							
6			ON	Lx1-Lx2							
7			ON	Lx1-Lx2							
8			ON	Lx1-Lx2							
9			ON	Lx1-Lx2							

7.11.10.3 BAL Formula Setup

Currently, there are 5 formulas to choose from, which are as follows:

Lx1-Lx2, DCR1-DCR2, DCR1-DCR2, DCR1-DCR2, DCR1-DCR2

When the absolute value switch is changed, it will affect the final result of this formula.

Trans Condition											Home
	Turn	Lx	Lk	Cx	Zx	ACR	DCR	PS	BAL		BAL
Freq(Hz)	10.0000k	10.0000k	10.0000k	10.0000k	10.0000k	10.0000k					
Level	1 V	300mV	300mV	300mV	300mV	300mV	2 V	2 V			Lx1-Lx2
Dev	OFF	Δ%	OFF	OFF	OFF	OFF	OFF				DCR1-DCR2
Average	1	1	1	1	1	1	1	1			Lk1-Lk2
Delay	0 s	0 s	0 s	0 s	0 s	0 s	0 s	0 s			Lk1/Lk2
Equ		Series	Series	Parallel		Series					Lx1/Lx2
Sequence	1	2	3	4	5	6	7	8	9		Return
Switch	ON	ON	ON	ON	ON	ON	ON	ON	ON		
BAL	B1	B2	Abs	Formula			Std	Low	High		
0	P01-P02	P11-P12	OFF	Lx1-Lx2							
1			ON	Lx1-Lx2							
2			ON	Lx1-Lx2							
3			ON	Lx1-Lx2							
4			ON	Lx1-Lx2							
5			ON	Lx1-Lx2							
6			ON	Lx1-Lx2							
7			ON	Lx1-Lx2							
8			ON	Lx1-Lx2							
9			ON	Lx1-Lx2							

7.11.11 Handler Mode Function

After a scan test, the Handler outputs the final sorting signal according to the settings here.

There are currently three sorting modes: default, X30, X12.

1. Default: output unqualified signals according to the parameters shown in the signal column in the table.
2. X30: According to the page in the table, a group of two pages will output the unqualified signal.
3. X12: According to the page in the table, a group of five pages will output the unqualified signal.

Handler Mode										Home	
Handler Mode					Interface					Handler - 1	Handler Mode
Pin	Signal	Page	Direction	Function	Pin	Signal	Page	Direction	Function	Default	
1	FAIL_01	A1-A2	Output		11,12,13	+5V	N/A	Output	Imax=0.3A	X30	
2	FAIL_02	A3-A4	Output		14,15,16,17	GND	N/A	Output	GND	X12	
3	FAIL_03	A5-B1	Output		18	24V-	N/A	Output	Cylinder -		
4	FAIL_04	B2-B3	Output		19	EXT_GND	N/A	Input	GND_EXT		
5	FAIL_05	B4-B5	Output		20	24V+	N/A	Output	Cylinder +		
6	FAIL_06	C1-C2	Output		21	EXT_VCC	N/A	Input	3.3V ~ 24V		
7	FAIL_07	C3-C4	Output		22	EXT_RESET	N/A	Input			
8	FAIL_08	C5-D1	Output		23	EXT_START	N/A	Input			
9	FAIL_09	D2-D3	Output		24	FAIL_ANY	ALL	Output			
10	TEST	N/A	Output		25	PASS_ALL	ALL	Output			

7.11.12 Parameter copy function

After setting the setting parameters of the transformer A board: such as Pin to Fixture, transformer pins and test conditions, using the parameter copy function to automatically copy the parameters of the A board to the B~L boards, which can save the time of repeatedly setting the parameters of the B~L board.

7.11.13 Statistics Page

On the transformer scan setting page, press the function key [Statistics], it will jump to the <Statistics> page.

Trans Stat				Home
	Pass	Fail	SUM	Trans Statistics
Turn				Trans ID
Lx				Pin To Fixture
Lk				Pin Setup
Cx				Condition
Zx				Copy
ACR				Handler Mode
DCR				Stat
PS				Tools
BAL				
Whole				

The page states the following:

[Pass] indicates the pass times of each parameter of L.K.~DCR.

[Pass]+[Whole]: In one measurement, all parameters that need to be measured in L.K.~DCR are qualified, then [Pass] corresponds to the value of [Whole] (total qualified column) plus 1.

[Fail] Indicates the fail times of each parameter of L.K.~DCR.

[Fail]+[Whole]: In one measurement, if one or more parameters to be measured in L.K.~DCR are unqualified, then [Fail] corresponds to the value of [Whole] (total unqualified column) plus 1.

[SUM] indicates the total measurement times of a measurement parameter;

[Whole]+[SUM] indicates the total number of measurements, which is equal to the total number of pass times and the total number of fail times.

7.11.13.1 Resetting the Statistical Count

Click on the statistics table and the [Reset Count] function will appear in the menu area. Pressing the [Reset Count] function button will reset all data in the table on the <Scan Test Statistics> page to zero.

7.12 <Trans Scan>

After all settings are completed, directly press the [Display] key to enter the <Trans Scan> page. Before starting the test, it is best for users to press the [File] key to enter the <File Management> page, and save the settings for calling of next boot. For details, see the description on the <File Management> page.

After saving the file, enter the <Trans Scan > page. If the user only uses the internal scanning board, just press the [TRIGGER] key on the front panel to trigger the test; If the user is using a scan box, make sure that the host and scan box are installed and connected correctly, at this time, you can place the transformer to be tested on the test fixture and press the [START] button on the scan box to start the scan test. The test value will be displayed on the screen. When the test is defective, the test value is displayed in red.

The instrument will display the scan data and the final PASS/FAIL according to the settings of the scan result display on the <Trans ID> page.

During scanning, if a certain pin of Lx or Zx is set to add DC bias current, the instrument will automatically add the corresponding DC bias current and light the [BIAS] button.

The screenshot shows the 'Trans Scan' interface with a data table and a control panel. The table has columns for A1, Pin, Turn-V, Lx(H), Lk(H), Cp(F), Zx(Q), ACR(Q), DCR(Q), PS, and Bala. The control panel on the right includes buttons for Pri, A1,A2, Load Std, OFF, Deviation, OFF, Speed, Fast, Test Fail, Continue, Focus, OFF, Split, 2-1, Save, and OFF. The status bar at the bottom right shows the date and time: 2022/01/20 08:24:58.

A1	Pin	Turn-V	Lx(H)	Lk(H)	Cp(F)	Zx(Q)	ACR(Q)	DCR(Q)	PS	Bala
0	P01-P02	1.0000	-382.87μ	-9.6958	001 - 013	11.633k	1.3556M	-750.00m	002 - 003	001-002k
1	P11-P12	207.97m	553.68μ	-9.4669	003 - 011	1.6621M	1.3588M	-890.00m	004 - 005	
2	P21-P22	148.96m	1.2310m	-4.5991		1.3641M	1.5967M	110.00m	008 - 009	
3	P31-P32								010 - 011	
4	P11-P22								012 - 013	
5	P11-P12								001 - 011	
6										
7										
8										
9										
A2	Pin	Turn-V	Lx(H)	Lk(H)	Cp(F)	Zx(Q)	ACR(Q)	DCR(Q)	PS	Bala
0	P61-P62	1.0000	-308.00m	-3.9079		1.6634M	1.4570M	8.4071M		
1	P11-P12	208.45m	-1.6171	-3.4051		1.4998M	1.4758M	6.6955M		
2	P21-P22	143.30m	-3.5710	-2.8760		1.5548M	1.5063M	-1.0000		
3	P31-P32									
4	P41-P42									
5	P51-P52									
6										
7										
8										
9										

7.12.1 Each Display Zone Under this page

PIN Area: the area below the column displays the pins of each winding, but the pins of Cx are not displayed in this area. When you need to check, you can press the [DISPLAY] key, and the pins will be displayed in the cell of the test result (Only the 1st of the positive and negative pins is displayed).

Each parameter test result display area (TURN, Lx, Q, Lk, Cx, D, ZX, ACR, DCR, PS, BAL): when all parameters are turned on, you can press the left and right keys or touch left and right to slide to view the not all displayed parameter.

7.12.2 Function Keys under this page

[TRIGGER] is used to start the instrument for scan testing.

[RESET] is used to interrupt an ongoing scan test.

[KEYLOCK] locks the keyboard. After locking the keyboard, the user can also perform other operations such as scan test, but the parameter settings cannot be modified. This function can be used to prevent testers from changing or deleting the set test conditions by mistake. Shut down after locking the keyboard, the current test file will be called automatically next time it is turned on.

[FILE] is used to enter the file management page.

[CAL] is used to turn on the open-circuit test fixture scanning correction function, as shown in the figure below:

A1	Pin	Turn-V	Lx(H)	Lk(H)	Cp(F)	Zx(Q)	ACR(Q)	DCR(Q)	PS	Bala	Cal
0	P01-P02	1.0000	-382.87μ	-9.8958	001 - 013	11.633k	1.3556M	750.00m	002 - 003	001.002k	Open
1	P11-P12	207.97m	553.68μ	-9.4669	003 - 011	1.6621M	1.3588M	890.00m	004 - 005		OFF
2	P21-P22	146.96m	1.2310m	-4.5691		1.3641M	1.5967M	110.00m	008 - 009		Short
3	P31-P32								010 - 011		OFF
4	P11-P22								012 - 013		Meas Open
5	P11-P12								001 - 011		Meas Short
6											
7											
8											
9											

A2	Pin	Turn-V	Lx(H)	Lk(H)	Cp(F)	Zx(Q)	ACR(Q)	DCR(Q)	PS	Bala
0	P61-P62	1.0000	-308.00m	-3.9079		1.6634M	1.4570M	8.4071M		
1	P11-P12	208.45m	-1.6171	-3.4051		1.4998M	1.4758M	6.6955M		
2	P21-P22	143.30m	-3.5710	-2.8760		1.5548M	1.5063M	-1.0000		
3	P31-P32									
4	P41-P42									
5	P51-P52									
6										
7										
8										
9										

At this time, put an open-circuit transformer sample with the same pin position as the product under test on the test fixture, and then press the soft key **Meas Open**, and the instrument will perform an open-circuit scan correction on the test fixture. This function can improve the test accuracy of small inter-turn capacitance and large inductance (>300mH level), and can also improve the open circuit value of DCR and PS.

High frequency open circuit can improve the test accuracy at high frequency.

[CAL] Turn on the short-circuit test fixture scan correction function:

At this time, put a short-circuit transformer sample with the same pin as the product under test on the test fixture, and then press the soft key **Meas Short**, and the instrument will perform short-circuit scan correction on the test fixture. This function can improve the test accuracy of small DC resistance and small inductance.

After the open and short correction, if you want to use the clear data in the test, you need to open the corresponding switch.

7.12.3 PRI page-turning function

In the transformer scan test interface, after testing a transformer with multiple primary windings, you can switch the primary (PRI) page with the knob to view the test results, and the untested pages will be ignored directly.

Trans Scan										I:\Files\GuideBook.t40	Setup
A1	Pin	Lx(H)	Lk(H)	Cp(F)	Zx(Ω)	ACR(Ω)	DCR(Ω)	PS	Balance		
0	P01-P02	-382.87μ	-9.6958	001 - 013	11.633k	1.3556M	-750.00m	002 - 003	001-002-003-004	Pri.	
1	P11-P12	553.68μ	-9.4669	003 - 011	1.6621M	1.3588M	890.00m	004 - 005		A1,A2	
2	P21-P22	1.2310m	-4.5691		1.3641M	1.5967M	110.00m	008 - 009		Load Std	
3	P31-P32							010 - 011		OFF	
4	P11-P22							012 - 013		Deviation	
5	P11-P12							001 - 011		OFF	
6										Speed	
7										Fast	
8										Test Fail	
9										Continue	
A2	Pin	Lx(H)	Lk(H)	Cp(F)	Zx(Ω)	ACR(Ω)	DCR(Ω)	PS	Balance		
0	P61-P62	-308.00m	-3.9079		1.6634M	1.4570M	8.4071M			Focus	
1	P11-P12	-1.6171	-3.4051		1.4998M	1.4758M	6.6955M			OFF	
2	P21-P22	-3.5710	-2.8760		1.5548M	1.5063M	-1.0000			Split	
3	P31-P32									2-1	
4	P41-P42									Save	
5	P51-P52									OFF	
6											
7											
8											
9											

Press the Knob key and the Primary (PRI) page will return to the A1 page.

7.12.4 Pin Display Function for Stray Capacitance

After testing the stray capacitance, press the Display key to view some pins of the current stray capacitance.

Trans Scan										I:\Files\GuideBook.t40	Setup
A1	Pin	Lx(H)	Lk(H)	Cp(F)	Zx(Ω)	ACR(Ω)	DCR(Ω)	PS	Balance		
0	P01-P02	-382.87μ	-9.6958	001 - 013	11.633k	1.3556M	-750.00m	002 - 003	001-002-003-004	Pri.	
1	P11-P12	553.68μ	-9.4669	003 - 011	1.6621M	1.3588M	890.00m	004 - 005		A1,A2	
2	P21-P22	1.2310m	-4.5691		1.3641M	1.5967M	110.00m	008 - 009		Load Std	
3	P31-P32							010 - 011		OFF	
4	P11-P22							012 - 013		Deviation	
5	P11-P12							001 - 011		OFF	
6										Speed	
7										Fast	
8										Test Fail	
9										Continue	
A2	Pin	Lx(H)	Lk(H)	Cp(F)	Zx(Ω)	ACR(Ω)	DCR(Ω)	PS	Balance		
0	P61-P62	-308.00m	-3.9079		1.6634M	1.4570M	8.4071M			Focus	
1	P11-P12	-1.6171	-3.4051		1.4998M	1.4758M	6.6955M			OFF	
2	P21-P22	-3.5710	-2.8760		1.5548M	1.5063M	-1.0000			Split	
3	P31-P32									2-1	
4	P41-P42									Save	
5	P51-P52									OFF	
6											
7											
8											
9											

7.12.5 BAL Balance parameter display

A1	Pin	Lx(H)	Lk(H)	Cp(F)	Zx(Ω)	ACR(Ω)	DCR(Ω)	PS	Balance
0	P01-P02	-382.87μ	-9.6958	001 - 013	11.623k	1.3558M	-750.00m	002 - 003	001-002-003-004
1	P11-P12	553.68μ	-9.4669	003 - 011	1.6621M	1.3588M	-890.00m	004 - 005	
2	P21-P22	1.2310m	-4.5691		1.3641M	1.5967M	110.00m	008 - 009	
3	P31-P32							010 - 011	
4	P11-P22							012 - 013	
5	P11-P12							001 - 011	
6									
7									
8									
9									

A2	Pin	Lx(H)	Lk(H)	Cp(F)	Zx(Ω)	ACR(Ω)	DCR(Ω)	PS	Balance
0	P61-P62	-308.00m	-3.9079		1.6634M	1.4570M	8.4071M		
1	P11-P12	-1.6171	-3.4051		1.4998M	1.4758M	6.6955M		
2	P21-P22	-3.5710	-2.8760		1.5548M	1.5063M	-1.0000		
3	P31-P32								
4	P41-P42								
5	P51-P52								
6									
7									
8									
9									

After the scan is over, press the Display key to switch to display the result value between the two windings of the BAL.

7.13 <File> page of Transformer Scan

Name	Size	Date Modified
files		2021/12/13 10:56:58
files		2021/12/13 10:56:37
0000.t40	453 KB	2021/11/02 13:49:42
0001.t40	453 KB	2021/11/04 09:54:57
001.t40	453 KB	2021/11/12 14:13:06
1.t40	453 KB	2021/11/04 10:16:06
0002.t40	453 KB	2021/11/04 15:28:19
002.t40	453 KB	2021/11/17 10:57:07
2.t40	453 KB	2021/11/04 10:17:14
3.t40	453 KB	2021/12/13 10:56:58
1831.t40	453 KB	2021/07/22 08:20:39
1901.t40	453 KB	2021/07/22 08:20:37
1111111.t40	453 KB	2021/08/03 11:21:17
2220329-QA3PC.t40	453 KB	2021/11/05 14:13:38
2250187-02FX-12B.t40	453 KB	2021/08/03 11:22:27
2250187-02FX-12C.t40	453 KB	2021/09/10 16:11:16
devT1.t40	453 KB	2021/09/27 10:56:39
devT2.t40	453 KB	2021/09/27 10:57:56
E-0409-H273.t40	439 KB	2021/07/22 08:20:34
G7202DG.t40	453 KB	2021/07/22 08:20:31
PinLabel.t40	453 KB	2021/10/12 15:25:27
STATE.sta	24 KB	2021/08/13 22:17:25

7.13.1 Transformer scan setup file (*.t40)

The internal space of the instrument can save a certain number of scan setting files (*.t40 files), the number is determined by the remaining internal storage space, and the scan setting files can also be displayed/operated through an external storage USB flash drive, and supports large-capacity USB flash drives (FAT32 format) read and write functions.

All setting data on the following pages will be saved or loaded in the form of files, called *.t40 files.

- <Trans ID>
- <Pin to Fixture>
- <Pin Setup>
- <Trans Condition>

-
- <Trans Deviation>
 - <Handler Mode>
 - Some menu functions in <Trans Scan Test>

7.13.1.1 U-disk manage performance

As mentioned above, the TH2840X is equipped with a USB HOST interface as standard, which can use an external USB flash drive as a storage medium, thus breaking through the storage limitation of the internal setting files of the instrument, and can also copy these files to an IBM PC with a USB interface or a compatible desktop, computer, notebook computer, so as to achieve unlimited expansion.

TH2840X supports the following USB mass storage devices (USB flash drives):

Compliant with USB 2.0 standard

Capacity: 2GB/4GB/8G/16G/32G

File format: FAT32 (formatted with Microsoft Windows operating system)

7.13.2 Operation steps for file manage

View existing files.

Click the [+] before the folder icon, or click the folder and right-click to view all the files in this folder.

Files saved in the root directory can be viewed directly by turning the knob counterclockwise.

Follow the steps below to save control setup parameters to a file.

First set all the control parameters of the desired page.

Press the soft key **File** to enter the file management page.

When you move the cursor to any file or folder, the menu will display the following:

Save.t40

Copy to E:

Rename

Delete

New folder

Select **Save.t40** to save the settings file.

After pressing the save soft key, the screen will display the soft keyboard.

Enter characters as the file name and press OK to save, press Esc to cancel saving the file.

When saving a file with the same file name, the "File Existing" dialog box will pop up. Select Overwrite to overwrite the file with the same name; select Rename to re-enter the file name; select Cancel to cancel the saving of this file.

Press the **DISPLAY** soft key to enter the transformer scan test page.

Follow the steps below to load control setup parameters from a file.

Press the soft key **File** to enter the file management page.

Selecting the .t40 file you want to load will display the following menu:

Load

Save.40

Copy to E:

Rename

Delete

New folder

Press the **Load** soft key and the screen will display the following menu.

Load

Cancel

Pressing **Cancel** will cancel the current load operation and return to step 1.

Press **Load** and the currently selected file will be loaded. At the same time, enter the <Trans Scan> page.

7.13.3 Transformer deviation-deduction

If user has the standard samples of untested transformer, and its data of each test can serve as the measurement standard, the deviation-deduction function is available.

The operation of deviation function is listed as below:

1. According to the set method, enter <Trans Scan> page after setting parameter.
2. Put standard transformer to test fixture and lock it, press [START] in scan box for several times to get a stable test value;
3. Press [Deviation] to enter <Trans Deviation> page; the figure is as below:

Para	Turn	Lx	Q	Lk	Cx	D	Zx	ACR	DCR	Dev value
High(%)	300	300	300	3k	300	300	300	300	500	PRI
Low(%)	-60	-60	-60	-90	-60	-60	-60	-60	-60	A1
Mode	OFF	DIV	OFF	OFF	OFF	OFF	OFF	OFF	SUB	Deviation
PRI.	P01-P02	1							1	OFF
SEC.1	P11-P12	1							1	Test & Load
SEC.2	P21-P22	1							1	Reset Column
SEC.3	P31-P32	1							1	Item
SEC.4	P11-P22	1								ON
SEC.5	P11-P12	1								Exit
SEC.6										
SEC.7										
SEC.8										
SEC.9										

4. Set [Deviation] as ON ;
5. Set the correction parameter switch as DIV or SUB ;
6. Set the high and low limits allowed for deduction of each parameter;
7. Press [Deviation] to perform correction, and back to <Trans Scan> page.
8. After the deduction is successful, if the user triggers the test again, the measured value displayed by the instrument will be the same as the value of the standard product.
9. If you need to check the deviation value used by each parameter at this time, just return to the <Trans Deviation > page to check.

Trans Deviation										Dev value
Para	Turn	Lx	Q	Lk	Cx	D	Zx	ACR	DCR	
High(%)	300	300	300	3k	300	300	300	300	500	PRI. A1
Low(%)	-60	-60	-60	-90	-60	-60	-60	-60	-60	Deviation 21/12/16 14:56
Mode	OFF	DIV	OFF	OFF	OFF	OFF	OFF	OFF	OFF	Test & Load
PRI.	P01-P02	-2.169m								Reset Column
SEC.1	P11-P12	-97.391μ								Item ON
SEC.2	P21-P22	-373.54μ								Exit
SEC.3	P31-P32	1								
SEC.4	P11-P22	1								
SEC.5	P11-P12	1								
SEC.6										
SEC.7										
SEC.8										
SEC.9										

NOTE: When modifying the DIV value, it can not be revised as 0.

If you need to save the deduction value, press the soft key **File** to enter the file management page, and follow the on-screen prompts to save the file so that the same transformer can be measured after the next restart.

7.14 Focus

The focus function makes it easier to repeat the test between the specified windings or between the specified parameters.

On the Trans Scan page, turn on the **Focus** switch, and then click the parameter you want to test repeatedly.

Click on the cell, when its background turns blue, it is in the selected state, at this time, press the Trigger key to measure the data of this cell;

Trans Scan										Setup
A1	Pin	Lx(H)	Lk(H)	Cp(F)	Zx(Q)	ACR(Q)	DCR(Q)	PS	Balance	
0	P01-P02			2.7340p						Pri. A1,A2
1	P11-P12									Load Std OFF
2	P21-P22									Deviation 21/12/16 14:56
3	P31-P32									Speed Fast
4	P11-P22									Test Fail Continue
5	P11-P12									Focus ON
6										Split 2-1
7										Save OFF
8										
9										
A2	Pin	Lx(H)	Lk(H)	Cp(F)	Zx(Q)	ACR(Q)	DCR(Q)	PS	Balance	
0	P61-P62									
1	P11-P12									
2	P21-P22									
3	P31-P32									
4	P41-P42									
5	P51-P52									
6										
7										
8										
9										

Click the parameter title to focus scan the parameter selected;

Trans Scan										I:\files\GuideBook.t40	Setup
A1	Pin	Lx(H)	Lk(H)	Cp(F)	Zx(Q)	ACR(Q)	DCR(Q)	PS	Balance		
0	P01-P02			1.3597p							
1	P11-P12			2.6370p							
2	P21-P22										
3	P31-P32										
4	P11-P22										
5	P11-P12										
6											
7											
8											
9											
A2	Pin	Lx(H)	Lk(H)	Cp(F)	Zx(Q)	ACR(Q)	DCR(Q)	PS	Balance		
0	P61-P62										
1	P11-P12										
2	P21-P22										
3	P31-P32										
4	P41-P42										
5	P51-P52										
6											
7											
8											
9											

Click Pin to focus scan all the data to be tested on a page.

Trans Scan										I:\files\GuideBook.t40	Setup
A1	Pin	Turn-V	Lx(H)	Lk(H)	Cp(F)	Zx(Q)	ACR(Q)	DCR(Q)	PS	Bala	
0	P01-P02	1.0000	-2.1207m	-3.1603	1.7227p	18.903k	1.3441M	-750.00m	3.9015M		
1	P11-P12	214.21m	506.68μ	-5.7133	3.1118p	1.7123M	1.3831M	110.00m	499.97k		
2	P21-P22	145.66m	1.2787m	-6.1429		1.5351M	1.3367M	110.00m	3.2010M		
3	P31-P32							M		
4	P11-P22								1.0999M		
5	P11-P12							M		
6											
7											
8											
9											
A2	Pin	Turn-V	Lx(H)	Lk(H)	Cp(F)	Zx(Q)	ACR(Q)	DCR(Q)	PS	Bala	
0	P61-P62										
1	P11-P12										
2	P21-P22										
3	P31-P32										
4	P41-P42										
5	P51-P52										
6											
7											
8											
9											

7.15 Split

When there are few transformer test parameters, and multiple transformers need to be tested at the same time, the split function can be switched to meet the test requirements.

Split functions are 2-1, 3-1, 4-1, 2-2, 3-2, 4-2. The default is 2-1.

If the table does not display all parameters, you can touch the corresponding table and slide left and right to view it, or press the left and right soft keys to view it directly.

Trans Scan										I:\files\GuideBook.t40	Setup
A1	Pin	Turn-V	Lx(H)	Lk(H)	Cp(F)	Zx(Q)	ACR(Q)	DCR(Q)	PS	Bala	
0	P01-P02	1.0000	-382.87μ	9.6956	001 - 013	11.633k	1.3556M	750.00m	002 - 003	001-002	
1	P11-P12	207.97m	553.68μ	-9.4669	003 - 011	1.6621M	1.3588M	890.00m	004 - 005		
2	P21-P22	146.96m	1.2310m	-4.3691		1.3641M	1.5967M	110.00m	008 - 009		
3	P31-P32								010 - 011		
4	P11-P22								012 - 013		
5	P11-P12								001 - 011		
6											
7											
8											
9											
A2	Pin	Turn-V	Lx(H)	Lk(H)	Cp(F)	Zx(Q)	ACR(Q)	DCR(Q)	PS	Bala	
0	P61-P62	1.0000	-308.00m	-3.9079		1.6634M	1.4570M	8.4071M			
1	P11-P12	208.45m	-1.6171	-3.4051		1.4998M	1.4758M	6.6955M			
2	P21-P22	143.30m	-3.5710	-2.8760		1.5548M	1.5063M	-1.0000			
3	P31-P32										
4	P41-P42										
5	P51-P52										
6											
7											
8											
9											

The screenshot shows the 'Trans Scan' software interface. The main window displays a table with columns: Pin, Turn-V, Lx(H), Lk(H), Cp(I), and a Setup menu. The table is divided into sections A1, A2, and a third unnamed section. The A1 section has data for Pin P01-P02, P11-P12, P21-P22, and P31-P32. The A2 section has data for Pin P61-P62, P11-P12, P21-P22, and P31-P32. The third section has data for Pin P01-P02, P11-P12, P21-P22, and P31-P32. The Setup menu on the right includes options like Pri., A1,A2, Load Std, OFF, Deviation, Speed, Test Fail, Focus, Split, Save, and OFF.

Section	Pin	Turn-V	Lx(H)	Lk(H)	Cp(I)
A1	P01-P02	1.0000	-2.1207m	-3.1403	1.722
	P11-P12	214.21m	506.68u	-5.7133	3.1111
	P21-P22	145.66m	1.2787m	-6.1429	
	P31-P32				
A2	P61-P62				
	P11-P12				
	P21-P22				
	P31-P32				
---	P01-P02				
	P11-P12				
	P21-P22				
	P31-P32				

7.16 Frequently asked questions and answers in transformer scan test

7.16.1 High and low limits

In test, if you find the test value of transformer is obviously and seriously unqualified, but the judge table still displays that the parameter is qualified.

Reason: User only sets standard value (STD but not the high/low limit or just set one of high/low limit value.

Solution: Set high and low limits.

7.16.2 Measurement item loss

In the process of test, user finds some parameter such as (Lx) is set to be tested, but the parameter is not tested and no data displays.

Reason: user only sets [\sqrt{X}] as $\sqrt{\quad}$, but does not set standard value on parameter set menu, and meanwhile, "Ignore std test" is set as "FORCE DEV" on [Trans ID].

Solution: 1. Set "Ignore std." as "FORCE TEST".

2. Set standard value on parameter limit setup menu.

7.16.3 Measurement interruption

In the process of test, user finds the instrument only tests the test parameter in the first several groups of value, but the last ones has not been tested.

Reason 1: When setting pin position, user only sets the first groups of pins, but does not set one or more group of pin in the middle, and then the left groups will not be set in the process of test.

Reason 2: On [Trans Scan], user sets Test Fail as STOP, so in test when some parameters are unqualified, then the test will not be performed.

Solution: set Test Fail as Continue, meanwhile, reset the blank pin on parameter limit setup menu or set "Ignore Std." as "FORCE TEST".

7.16.4 Poor DCR accuracy

If the sheet metal is oxygenized, tore and defaced, or user makes a fixture without applying 4-cable test method, it will cause the deviation of DCR.

Solution:

1. Keep the sheet metal being new, so it can contact with transformer pin well.
2. Use 4-cable measurement. Refer to User-made test fixture.
3. Use deviation deduction.

7.16.5 Poor Lk accuracy

If the sheet metal is oxygenized, tore and defaced, or the lead resistance of user-made test fixture is too large, It will cause the deviation when testing Lk.

Solution:

1. Keep the sheet metal being new, so it can contact with transformer pin well.
2. Use 4-cable measurement. Refer to User-made test fixture
3. Use deviation deduction.

7.16.6 Inaccurate TURN

For transformers with low magnetic permeability magnetic-core, the number of winding is not the same with that of real winding because the inductor will take some ACR voltage.

Resolution:

Use the **TURN** mode to test winding.

7.16.7 Unstable TURN

For the transformer with high magnetic permeability magnetic-core, test winding will be unstable.

Solution:

1. Use the TURN_V mode to test winding (voltage-turn mode).
2. Use deviation deduction.

7.16.8 Difference between the first and the second Lx

Because the transformer, with high magnetic permeability magnetic-core, is polarized in the test of DCR or TURN, the test results of the first and the second Lx test will be quite different.

Solution:

Use 100 ohm internal resistance when testing TURN.
Use 100 ohm internal resistance when testing DCR.

7.16.9 Poor stability of Cx and Zx open test data

If the shielding and ground of test system is not good, it will cause the test value unstable when testing Cx or Zx.

Solution:

Through a thick metal lead, connect ground poles of the instrument and the scan box as well as the metal frame of the test fixture together and ground it reliably.

7.16.10 DCR and PS open cannot reach infinite large

Due to the existence of circuit distribution parameter, so the infinite large cannot be displayed when testing DCR or PS open, it is a normal phenomenon, if user wants to display it, execute the sweep open correction function on the test fixture.

7.17 User-made test fixture

There are many kinds of transformers, so our company can't offer a test fixture to each transformer, which requires user to make a test fixture according to some principles. The followings are caution items of making test fixture:

1. Use 4-cable measurement method to extend test cable. Don't use 5.0mm test fixture to hold test lead.
2. Use multi-strand lacquer cable with good tenacity to be the test extension cable. And use the stands as much as possible to reduce the resistance of cable.
3. Use high frequency test, and reduce the distribution parameter within extension cable, don't use ribbon cable to extend.
4. It is better to use metal frame which is connected to ground pole through a thick metal lead.

7.17.1 Use TH1801-EXT2A-OUT to make test fixture

User should buy the TH1801-EXT2A extension ground board from our company. The figure below also shows the connection of using 2 spring thimble to make test probe.

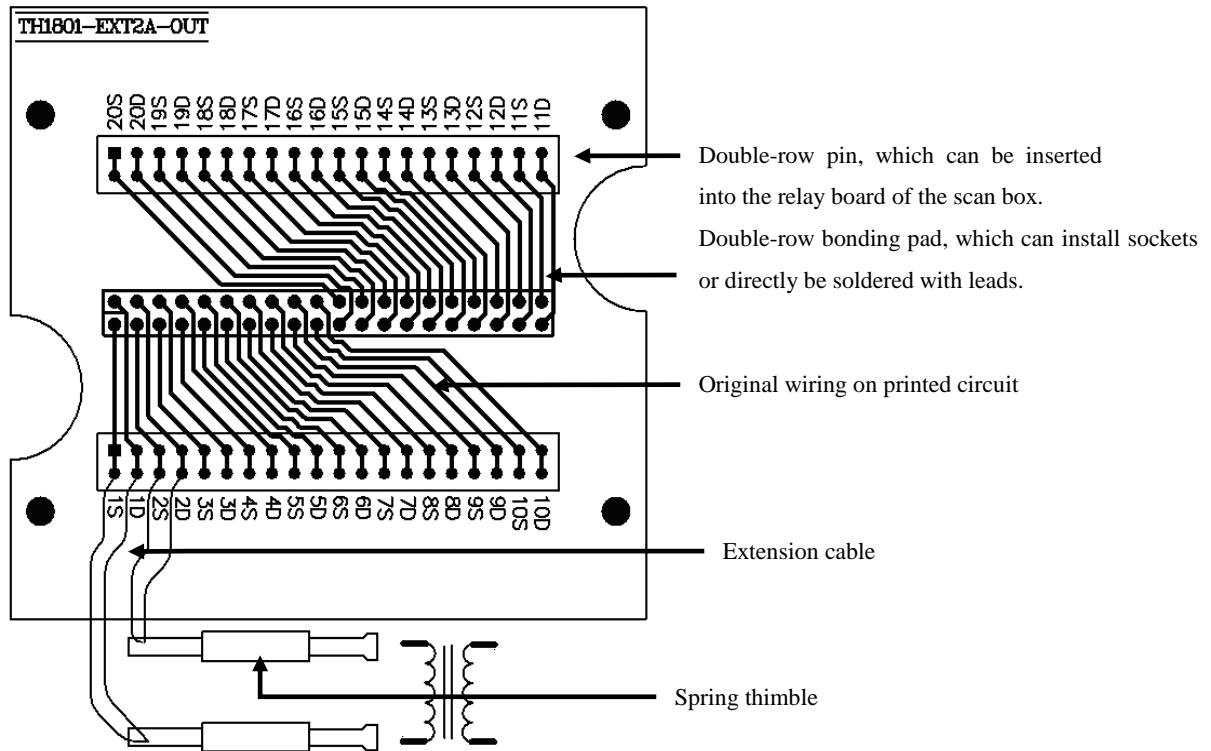

The theory of 4-cable measurement is the test cable of DRIVE and SENSE should be divided. In this figure, 1 D means the drive terminal of pin 1, 1 S means sense terminal of pin 1 .

7.17.2 Example of using TH1801-EXT11A(5.0)-B pin signal

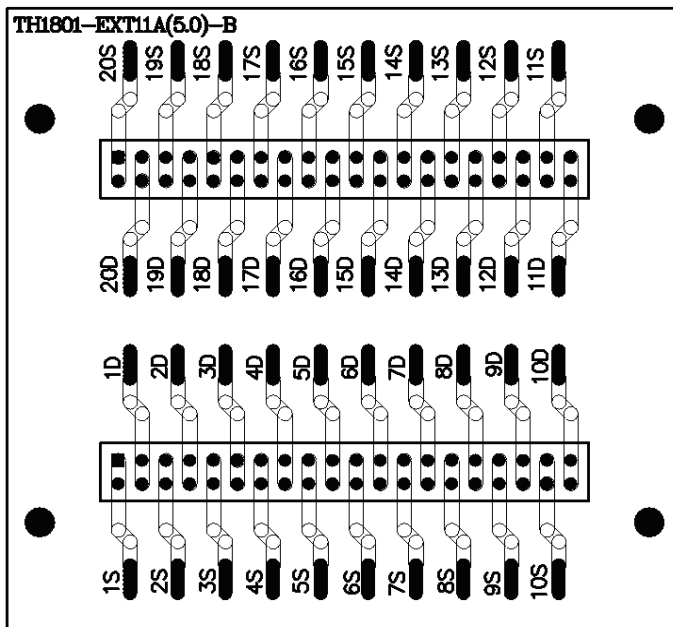

The theory of 4-cable measurement is the test cable of DRIVE and SENSE should be divided. In this figure 1 D means the drive terminal of pin 1 , 1 S means sense terminal of pin 1 .

Chapter 8 Performance and Test

8.1 Test function

8.1.1 Parameter and symbol

8.1.1.1 LCR Module

Parameter name	Parameter meaning	Parameter name	Parameter meaning
Cp	Equivalent parallel capacitance	Cs	Equivalent series capacitance
Lp	Equivalent parallel inductance	Ls	Equivalent series inductance
Rp	Equivalent parallel resistance	Rs	Equivalent series resistance
Gp	Conductance	Bp	Susceptance
Z	Absolute value of impedance	Y	Absolute value of admittance
D	Loss factor	Q	Quality factor
θ_z°	Impedance degree	θ_z	Impedance radian
θ_y°	Admittance degree	θ_y	Admittance radian
X	Reactance	Rd	DC Resistance

8.1.1.2 Transformer single group module

Parameter name	Parameter meaning	Parameter name	Parameter meaning
Cp	Equivalent parallel capacitance	Cs	Equivalent series capacitance
Lp	Equivalent parallel inductance	Ls	Equivalent series inductance
Rp	Equivalent parallel resistance	Rs	Equivalent series resistance
D	Loss factor	Q	Quality factor
Zx	Absolute value of impedance	Rd	DC Resistance
Lk	Leakage inductance	dZ	Impedance angle

Ns	Secondary turn	Ns:Np	Secondary turn /primary turn
Np	Primary turn	Np:Ns	Primary turn /secondary turn

8.1.1.3 Transformer Scan

8.1.2 Test combination

Four parameters can be selected arbitrarily, regardless of primary and secondary parameters.

8.1.3 Mathematical operation

Operation between the measurement value and the programmable nominal value: absolute deviation Δ ABS and percent deviation $\Delta\%$.

8.1.4 Equivalent mode

Series and parallel

8.1.5 Range

Auto, Manual (Hold, increase and decrease)

8.1.6 Trigger

Single, continue.

Continue: Continuously measure the DUT and output the results for display;

Single: Press the "TRIGGER" key on the panel, the HANDLER interface of the instrument receives the "start" signal from the outside, use the foot switch or use the bus trigger command to make the instrument perform a measurement and output the result and display it, usually in a waiting state.

8.1.7 Delay time

Trigger delay: the time from trigger to start of measurement. 0-60 seconds, programmable, in 1ms step;

Step delay: the delay time before the test signal is output to the measurement. 0-60 seconds, programmable, in 1ms step.

8.1.8 Connection modes of test terminals

TH2840X adopts 4-terminal test method.

Hcur: current sample high terminal

Lcur: Current sample low terminal

Hpot: voltage sample high terminal

Lpot: Voltage sample low terminal

8.1.9 Test speed (Frequency \geq 10kHz)

Fast+: about 1800 times/s (0.55ms/time)

Fast: about 300 times/s (3.3ms/time)

Medium: about 11 times/s (90ms/time)

Slow: about 4times/s (240ms/time)

The fast+, fast and middle speed will be slow down when frequency <10 kHz.

8.1.10 Average

255 programmable

8.1.11 Display digit

6 digits, max. displayed digit: 999999

8.2 Test signal

8.2.1 Test signal frequency

Test signal is sine wave, accuracy: 0.01%

Frequency range:

20Hz \sim 500kHz (TH2840A/TH2840AX/TH2840NX)

20Hz \sim 2MHz (TH2840B/TH2840BX)

Min. resolution: 1mHz

8.2.2 Signal mode

Normal: When testing, on measurement display page, voltage across test terminals may be smaller than preset voltage.

Constant level: The auto adjustment of internal level makes the voltage of DUT accordant with preset voltage.

8.2.3 Test signal level

	Mode	Frequency	Range	Accuracy	Resolution
Voltage	Normal	$\leq 1\text{MHz}$	5mVRMS—20VRMS	$\pm(10\% \times \text{preset value} + 2\text{mV})$	100 μV
	Constant Level	$> 1\text{MHz}$	5mVRMS—15VRMS	$\pm(6\% \times \text{preset value} + 2\text{mV})$	
Voltage	Normal	20~2MHz	50 μARMS	$\pm(10\% \times \text{preset value} + 10\mu\text{A}_{\text{RMS}})$	1 μA
	Constant Current		—100mARMS		

8.2.4 Output impedance

30 $\Omega \pm 4\%$ and 100 $\Omega \pm 2\%$ are selectable.

8.2.5 Monitor for test signal level

Mode	Frequency	Range	Accuracy
Voltage	$\leq 1\text{MHz}$	5mV _{RMS} —20V _{RMS}	$\pm(3\% \times \text{reading} + 0.5\text{mV})$
	$> 1\text{MHz}$	5mV _{RMS} —15V _{RMS}	$\pm(6\% \times \text{reading} + 0.5\text{mV})$
Current	$\leq 1\text{MHz}$	50 μA_{RMS} —100mA _{RMS}	$\pm(3\% \times \text{reading} + 5\mu\text{A})$
	$> 1\text{MHz}$	50 μA_{RMS} —100mA _{RMS}	$\pm(6\% \times \text{reading} + 5\mu\text{A})$

8.2.6 Maximum measurement display range

Parameter	Measurement display range
L、Lk	0.00001 μH ~ 99.9999kH
C	0.00001pF ~ 9.99999F
Z、R、X、DCR	0.00001 Ω ~ 99.9999M Ω
Y、B、G	0.00001 μS ~ 99.9999S
D	0.00001 — 9.99999
Q	0.00001 — 99999.9
θ	Deg -179.999 $^{\circ}$ ~ 179.999 $^{\circ}$ Rad -3.14159 ~ 3.14159
Turns Ratio	1: 0.001—1000: 1

8.2.7 DC bias voltage source

0V— $\pm 40\text{V}$ Minimum resolution: 1mV, Accuracy: 1% \times preset voltage+5mV

0mA—±100mA Minimum resolution: 10μA

8.2.8 2A Bias Current Source

Range	Resolution	Accuracy (I > 5mA)
0-2A	1mA	± (2% ×set value+2mA)

8.3 Measurement accuracy

Test accuracy includes stability、temperature coefficient, linear degree, test repeatability and calibration inter-error.

Check the accuracy of instrument should be under the following circumstances:

- warm-up time: ≥ 60 minutes
- cable: 0m, 1m
- correct open and short correction after warming up
- DC bias is in the position of “OFF”
- The range works in “AUTO” to select correct test range

8.3.1 Accuracy of | Z | , | Y | , L, C, R, X, G, B

The accuracy A_e of | Z | , | Y | , L, C, R, X, G and B are expressed as:

$$A_e = \pm [A_L \times A + (K_a + K_b + K_c) \times 100 + K_d + K_f] \times K_e \quad [\%]$$

A: basic test accuracy (figure A)

A_L : level correction factor (table A)

K_a : impedance rate factor (table B)

K_b : impedance rate factor (table B)

K_c : calibrated interpolating factor (table E)

K_d : cable length factor (table G)

K_e : temperature factor (table H)

K_f : scan fixture modification factor (no adding: $K_f = 0$, adding: $K_f = 0.2$)

Using condition of L, C, X, B accuracy A_e : D_x (test value of D) ≤ 0.1

Using condition of R, G accuracy A_e : Q_x (test value of Q) ≤ 0.1

When $D_x \geq 0.1$, accuracy factor A_e of L, C, X, B should be multiplied by $\sqrt{1 + D_x^2}$

When $Q_x \geq 0.1$, accuracy factor A_e of R, G should be multiplied by $\sqrt{1 + Q_x^2}$

8.3.2 D accuracy

The accuracy of D is given by the formula below:

$$D_e = \pm \frac{A_e}{100}$$

The formula is only available when $D_x \leq 0.1$.

When $D_x > 0.1$, D_e should be multiplied by $(1 + D_x)$

8.3.3 Q accuracy

The accuracy of Q is given by the formula below:

$$Q_e = \pm \frac{Q_x^2 \times D_e}{1 \mu Q_x \times D_e}$$

Where, Q_x is the value of the tested Q.

D_e is the accuracy of D

Above formula should be used when $Q_x \times D_e < 1$.

8.3.4 θ accuracy

The accuracy of θ is given by the formula below:

$$\theta_e = \frac{180}{\pi} \times \frac{A_e}{100} \quad [\text{deg}]$$

8.3.5 G accuracy

When D_x (tested value of D) ≤ 0.1

The accuracy of G is given by the formula below:

$$G_e = B_x \times D_e \quad [S]$$

$$B_x = 2\pi f C_x = \frac{1}{2\pi f L_x}$$

Where, B_x is the value of tested B with the unit [S].

C_x is the value of tested C with the unit [F].

L_x is the value of tested L with the unit [H].

D_e is the accuracy of D.

F is test frequency.

8.3.6 Rp accuracy

when D_x (value of tested D) ≤ 0.1

The accuracy of R_p is given by the formula below:

$$R_{pe} = \pm \frac{R_{px} \times D_e}{D_x \mp D_e} \quad [\Omega]$$

Where, R_{px} is the value of tested R_p with the unit [S].

D_x is the value of test D with the unit [F].

D_e is the accuracy of D.

8.3.7 Rs accuracy

when D_x (value of tested D) ≤ 0.1

The accuracy of R_s is given by the formula below:

$$R_{se} = X_x \times D_e \quad [\Omega]$$

$$X_x = 2\pi f L_x = \frac{1}{2\pi f C_x}$$

Where, X_x is the value of test X with the unit [S].

C_x is the value of test C with the unit [F].

L_x is the value of test L with the unit [H].

D_e is the accuracy of D

F is test frequency

8.3.8 DCR accuracy

$$A(1+R_x/5M\Omega+16m\Omega/R_x)[\%] \pm 0.2m\Omega$$

Medium speed and slow speed, A=0.25

Fast speed, A=0.5

Here, R_x is the measured resistance.

8.3.9 Lk accuracy

Inductance L accuracy +0.2%

8.3.10 Turns Ratio accuracy

$$\pm At \times Ar (1+1\Omega/Z_p+1/Q) [\%] \pm 0.002$$

Fast speed, AT=0.5

Medium speed and slow speed, AT=0.25

Z_p is the impedance of the measured primary inductance

Ar is the correction value of the test signal accuracy in Figure B

This accuracy index is used when the coupling coefficient of the transformer under test is 1 or close to 1.

8.3.11 Accuracy factor Figure A

Figure 8-1 Basic measurement accuracy factor A

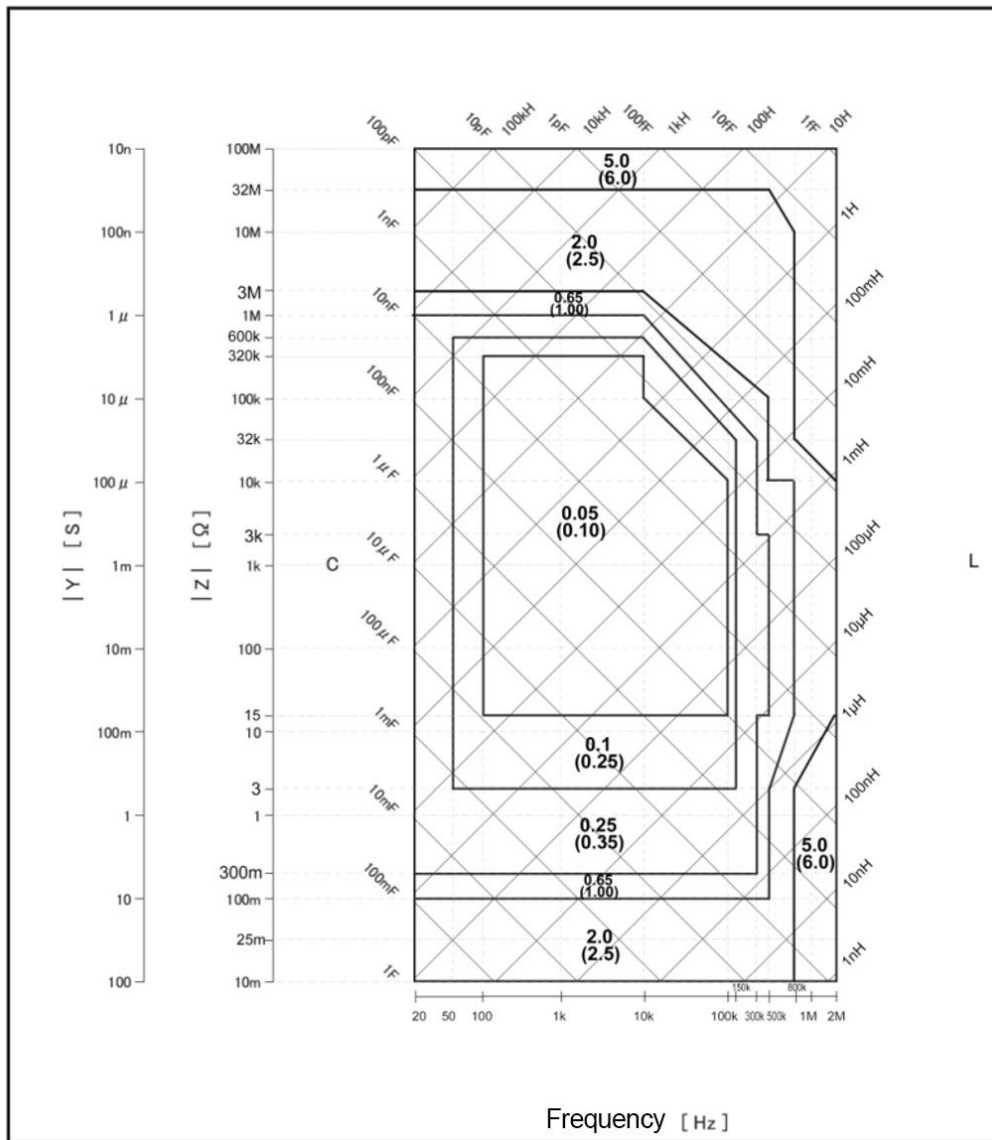

In Figure 8-1, the basic measurement accuracy factor A is selected as follows:

Figure 8-1 above is divided into a number of basic measurement accuracy picture boxes depending on the frequency and the impedance/capacitance/inductance of the measured part. (If on the boundary line, select the smaller value of A.) Each box includes the upper and lower values of the basic measurement accuracy A. The distinction between the upper and lower values is based on the measurement speed.

For example, the middle box is 0.05 (upper)/(0.1) (lower), under the same conditions:

When the measuring speed is medium or slow, select the upper data, such as 0.05.

When the measuring speed is fast, select the data in the lower bracket (), such as 0.1.

8.3.11.1 Table A Level correction factor AL

The basic accuracy A in Figure 8-1 above applies to a test level in the range of 500mVrms to 1Vrms, and when this level range is exceeded, the current basic measurement accuracy is obtained by calculating A based on the value of AL as determined in Table A below (new A value = A value of the corresponding condition in Figure 8-1 * AL).

Table A: Level correction factor AL (Vs is the test signal voltage)

Vs (Vrms)	[5m, 50m]	(50m,200m]	(200m, 500m]	(500m, 1]	(1,2]	(2,20]
AL	2.5×50mVrms / Vs	2.5	500mVrms / Vs	1	Vs	4

Note: If all of the following measurement conditions are met, the A value is increased by 0.15.

Test frequency: 100Hz<fm≤2MHz

Test signal voltage: 5Vrms<Vs≤20Vrms

DUT: Inductor, |Zm| <200Ω (|Zm| : DUT impedance)

8.3.11.2 Table B Impedance rate factors: Ka, Kb

Speed	Frequency	Ka	Kb
Medium Slow	fm≤1.2kHz	$\left(\frac{1 \times 10^{-3}}{ Z_m }\right)\left(1 + \frac{200}{V_s}\right)\sqrt{\frac{100}{f_m}}$	$ Z_m (0.3 \times 10^{-9})\left(1 + \frac{70}{V_s}\right)\sqrt{\frac{100}{f_m}}$
	1.2kHz<fm ≤8kHz	$\left(\frac{1 \times 10^{-3}}{ Z_m }\right)\left(1 + \frac{200}{V_s}\right)$	$ Z_m (1 \times 10^{-9})\left(1 + \frac{70}{V_s}\right)$
	8kHz<fm ≤150kHz		$ Z_m (3 \times 10^{-9})\left(1 + \frac{70}{V_s}\right)$
	150kHz<fm ≤1MHz	$\left(\frac{1 \times 10^{-3}}{ Z_m }\right)\left(3 + \frac{200}{V_s}\right)$	$ Z_m (10 \times 10^{-9})\left(1 + \frac{70}{V_s}\right)$
	1MHz<fm ≤2MHz	$\left(\frac{1 \times 10^{-3}}{ Z_m }\right)\left(30 + \frac{200}{V_s}\right)$	$ Z_m (100 \times 10^{-9})\left(1 + \frac{70}{V_s}\right)$
Fast	fm≤1.2kHz	$\left(\frac{2.5 \times 10^{-3}}{ Z_m }\right)\left(1 + \frac{400}{V_s}\right)\sqrt{\frac{100}{f_m}}$	$ Z_m (0.6 \times 10^{-9})\left(1 + \frac{100}{V_s}\right)\sqrt{\frac{100}{f_m}}$
	1.2kHz<fm ≤8kHz	$\left(\frac{2.5 \times 10^{-3}}{ Z_m }\right)\left(1 + \frac{400}{V_s}\right)$	$ Z_m (2 \times 10^{-9})\left(1 + \frac{100}{V_s}\right)$
	8kHz<fm ≤150kHz		$ Z_m (6 \times 10^{-9})\left(1 + \frac{100}{V_s}\right)$
	150kHz<fm ≤1MHz	$\left(\frac{2.5 \times 10^{-3}}{ Z_m }\right)\left(2 + \frac{400}{V_s}\right)$	$ Z_m (20 \times 10^{-9})\left(1 + \frac{100}{V_s}\right)$

1MHz<fm ≤2MHz	$\left(\frac{2.5 \times 10^{-3}}{ Z_m }\right) \left(20 + \frac{200}{V_s}\right)$	$ Z_m \left(100 \times 10^{-9}\right) \left(1 + \frac{100}{V_s}\right)$
------------------	---	--

fm: test frequency [Hz]

|Zm|impedance of the measured part [Ω]

Vs test signal voltage [mVrms]

Ka is used when the impedance is less than 500 Ω , Kb is invalid.

Kb is used when the impedance is greater than 500 Ω , Ka is invalid.

8.3.11.3 Table C when the cable length is extended, Ka should add the following value:

Cable length L [m]	0	1	2
Added value of Ka	0	0.0005	0.0010

8.3.11.4 Table D when the cable length is extended, Kb should multiply the following value:

Cable length L [m]	0	1	2
fm≤100kHz	1	1+5×fm	1+10×fm
100kHz<fm≤300kHz	1	1+2×fm	1+4×fm
300kHz<fm≤2MHz	1	1+0.5×fm	1+1×fm

Where, fm is the test frequency and the unit is [MHz].

8.3.11.5 Table E calibrated interpolating factor Kc

Test frequency	Kc
Direct calibrated frequency (listed in Table F)	0
Other frequency	0.0003

8.3.11.6 Table F Direct Calibrated frequency

			20	25	30	40	50	60		80		[Hz]
100	120	150	200	250	300	400	500	600		800		[Hz]
1	1.2	1.5	2	2.5	3	4	5	6		8		[kHz]
10	12	15	20	25	30	40	50	60		80		[kHz]
100	120	150	200	250	300	400	500	600	700	800	900	[kHz]
1	1.1	1.2	1.3	1.4	1.5	1.6	1.7	1.8	1.9	2		[MHz]

There are 60 frequencies in Table F. The highest frequency of TH2840A/AX/NX up to 500kHz and the highest frequency of TH2840B/BX up to 2M.

8.3.11.7 Cable length factor K_d

Test signal level	Cable length		
	1m	2m	4m
$\leq 2V_{rms}$	$2.5 \times 10^{-4} (1+50 \times f_m)$	$5 \times 10^{-4} (1+50 \times f_m)$	$1 \times 10^{-3} (1+50 \times f_m)$
$> 2V_{rms}$	$2.5 \times 10^{-3} (1+16 \times f_m)$	$5 \times 10^{-3} (1+16 \times f_m)$	$1 \times 10^{-2} (1+16 \times f_m)$
f_m : test frequency [MHz]			

8.3.11.8 Table G Temperature factor K_e

Temperature ($^{\circ}C$)	0 - 18	18 - 28	28 - 40
K_e	4	1	4

8.4 Performance test

8.4.1 Working condition

All tests should be performed under the working condition listed in Chapter 1. In this part, only the main indexes are listed. Users can make test under the specified condition mentioned in this manual. Performance test can be worked in the warm up conditions discussed in Chapter 1.

8.4.2 The used instruments and devices

No.	Instrument and Device	Specification	
1	Standard capacitor	100pF	0.02% D is known
		1000pF	
		10000pF	
		10nF	
		0.1uF	
		1uF	
2	AC standard resistor	10 Ω	0.02%
		100 Ω	
		1k Ω	
		10k Ω	
		100k Ω	
3	DC standard resistor	0.1 Ω	0.02%
		1 Ω	
		10 Ω	

		100Ω	
		1kΩ	
		10kΩ	
		100kΩ	
4	Standard inductor	100μH	0.02%
		1mH	
		10mH	
		100mH	
5	Frequency counter		(0~1000) MHz
6	Digital Multimeter		0.5%
7	Insulation resistance meter		500V 10 levels
8	Hipot Tester		0.25kW (0~500) V

8.4.3 Function check

Ensure function keys, displayer and terminal etc. can work normally.

8.4.4 Test signal level

Adjust multimeter in AC voltage range, where one test cable is connected to H_{CUR} and the other is connected to ground terminal. Change level as: 10mV, 20mV, 100mV, 200mV, 1V, 2V, 10V or 20V, the reading should meet the demand of test signal level in this chapter.

8.4.5 Frequency

Connect frequency meter to ground terminal. The test terminal of the frequency meter is connected with H_{CUR}. Change the frequency as: 20Hz, 100Hz, 1kHz, 10kHz, 100kHz, 200kHz, 500 kHz, 1MHz, 2MHz. The reading of frequency meter should meet the demand of the test signal frequency in this chapter.

8.4.6 Measurement accuracy

Basic parameters are R, L, C and D, so measurement accuracy is mainly about R, L, C and D.

8.4.7 Accuracy of C and D

Test condition:

Function	C _p -D				
Test frequency	100Hz	1kHz	10kHz	100kHz	Test respectively
Level	1V				
Range	AUTO				

Bias 0V
Speed Slow

Open and short correction should be made before testing. Connect standard capacitors: 100pF, 1000pF, 10nF, 0.1uF, 1uF and change the frequency. The error capacitance C between reading and nominal value should be in the range ruled in this chapter, dissipation D should be in the range ruled in this chapter.

8.4.8 Accuracy of L

Test condition:

Function L_s-Q
Test frequency 100Hz 1kHz Test respectively
Level 1V
Range AUTO
Bias 0V
Speed Slow

Open and short correction should be made before testing. Connect standard inductors: 100μH, 1mH, 10mH, 100mH and change the frequency. The error between the instrument reading and the standard value should be within the allowable error range specified in this chapter for L accuracy.

8.4.9 Accuracy of Z

Test condition:

Function Z-θ
Test frequency 100Hz 1kHz 10kHz 100kHz Test respectively
Level 1V
Range AUTO
Bias 0V
Speed Slow

Open and short correction should be made before testing. Connect standard AC resistors: 10Ω, 100Ω, 1kΩ, 10kΩ, 100kΩ and change the frequency. The error between the instrument reading and the standard value should be within the allowable error range specified in this chapter for the accuracy of |Z|.

8.4.10 Accuracy of DCR

Test condition

Function DCR
Test frequency -----
Level -----
Range AUTO
Bias -----
Speed Slow

Short correction should be made before testing. Connect standard DC resistors: 0.1 Ω , 1 Ω , 10 Ω , 100 Ω , 1k Ω , 10k Ω , 100k Ω . The error between the instrument reading and the standard value should be within the allowable error range specified in this chapter for DCR accuracy.

Chapter 9 Command Reference

9.1 GPIB Common Commands

- *RST ● *TRG ● *IDN ● *TST
- *ESE ● *SRE ● *ESR ● *STB
- *OPC ● *CLS

- The *RST command resets the instrument.
For example: WrtCmd (“*RST”)
- The *TRG command triggers the measurement and then sends the result.
For example: WrtCmd (“*TRG”)

Test page											
LCR Meter	Component testing	Parameter 1 Result, Parameter 2 Result, Parameter 3 Result, Parameter 4 Result, the sorting results: such as: 1.12345E2, 1.23456E-2, 1.11023E2, -1.12345E2,1 The sorting results take the following values: <table border="1" style="margin-left: auto; margin-right: auto;"> <thead> <tr> <th>Sorting result</th> <th>Description</th> </tr> </thead> <tbody> <tr> <td style="text-align: center;">0</td> <td style="text-align: center;">BIN OUT</td> </tr> <tr> <td style="text-align: center;">1~10</td> <td style="text-align: center;">BIN 1~10</td> </tr> </tbody> </table>		Sorting result	Description	0	BIN OUT	1~10	BIN 1~10		
	Sorting result	Description									
	0	BIN OUT									
	1~10	BIN 1~10									
List sweep	Single-Step	Click index, parameter 1 result, parameter 2 result, parameter 3 result, parameter 4 result, the compare results: such as: 2,1.12345E2,1.23456E-2,1.11023E2,-1.12345E2,1 The comparison results are as follows: <table border="1" style="margin-left: auto; margin-right: auto;"> <thead> <tr> <th>Compare results</th> <th>Description</th> </tr> </thead> <tbody> <tr> <td style="text-align: center;">0</td> <td style="text-align: center;">Not Compare</td> </tr> <tr> <td style="text-align: center;">1</td> <td style="text-align: center;">Pass</td> </tr> <tr> <td style="text-align: center;">Other</td> <td style="text-align: center;">Fail</td> </tr> </tbody> </table>		Compare results	Description	0	Not Compare	1	Pass	Other	Fail
Compare results	Description										
0	Not Compare										
1	Pass										
Other	Fail										
	Sequence	All point data will be returned after the test of all points, the data format is the same as above.									
Trace Sweep	Single-Step	Click index, parameter 1 result, parameter 2 result, parameter 3 result, parameter 4 result, such as: 2,1.12345E2,1.23456E-2,1.11023E2,-1.12345E2									
	Sequence	All point data will be returned after the test of all points, the data format is the same as above.									

Transformer	Single test	Single-Step	Serial number index, parameter name, parameter result comparison result, such as: 2,lx,1.12345E2,1 The comparison results are as follows: <table border="1" data-bbox="863 365 1200 577"> <thead> <tr> <th>Compare results</th> <th>Description</th> </tr> </thead> <tbody> <tr> <td>0</td> <td>Not Compare</td> </tr> <tr> <td>1</td> <td>Pass</td> </tr> <tr> <td>Other</td> <td>Fail</td> </tr> </tbody> </table>	Compare results	Description	0	Not Compare	1	Pass	Other	Fail
		Compare results	Description								
	0	Not Compare									
1	Pass										
Other	Fail										
Sequence	All point data will be returned after the test of all points, the data format is the same as above.										
Scan											

- The *IDN? query returns the instrument ID.
 Query syntax: *IDN?
 Return format: <model>,<firmware>,<sn>
 Where,
 <model> Instrument Model (TH2840)
 <firmware> Firmware Version (VER1.0.0)
 <sn> Instrument serial number (sn12345678)
 <date> Software release date (e.g., 2024-03-14)

9.2 SCPI Command

You can log in to the company website www.tonghui.com.cn for reference.

SCPI (Standard Command for Programmable Instruments) is an ASCII-based instrument command language used in test and measurement instruments. SCPI commands are based on a hierarchical structure (also known as a tree system). In this system, related commands are grouped under a common node or root, thus forming a subsystem.

According to the command syntax, most commands (and some parameters) are represented by a mixture of uppercase and lowercase letters. Uppercase letters indicate the abbreviation of the command. For shorter program lines, you can send commands in abbreviated format. If you want better program readability, you can send long format commands.

Note: To avoid misunderstanding of abbreviations, the command descriptions will avoid excessive abbreviations as much as possible. Most of the command descriptions are given directly in abbreviated form.

Grammatical conventions:

[SOURce[1|2]:]VOLTage:UNIT {VPP|VRMS|DBM}

[SOURce[1|2]:]FREQuency:CENTer {<frequency>|MINimum|MAXimum|DEFAULT}

Note: Command syntax conventions:

- The braces ({ }) contain the parameter options for the given command string. Braces are not sent with the command string.

-
- A vertical bar (|) separates multiple parameter selections for a given command string. For example, in the above command, {VPP|VRMS|DBM} means you can specify "VPP", "VRMS" or "DBM". The bars are not sent with the command string.
 - The angle brackets (< >) in the second example indicate that you must specify a value for the parameter inside the parentheses. For example, in the above syntax statement, the parameter in angle brackets is <frequency>. Angle brackets are not sent with the command string. You must specify a value for the parameter (for example "FREQ: CENT 1000") unless you choose another option (such as "FREQ: CENT MIN") that appears in the syntax.
 - Some syntax elements (such as nodes and parameters) are enclosed in square brackets ([]). This means that the element is optional and can be omitted. Angle brackets are not sent with the command string. If no value is specified for the optional parameter, the instrument will choose the default value. In the above example, "SOURce[1|2]" means that you can refer to source channel 1 by "SOURce" or "SOURce1", or "SOUR1" or "SOUR". Also, since the entire SOURce node is optional (in square brackets), you can also refer to channel 1 by completely omitting the SOURce node. This is because channel 1 is the default channel for the SOURce language node. On the other hand, to refer to channel 2, you must use "SOURce2" or "SOUR2" in the program line.
 - ^END: The EOI (end) signal of the IEEE-488 bus.

The signs in this manual are as follows:

NR1: integer, e.g.:123

NR2: fix-point number, e.g.: 12.3

NR3: floating-point number, e.g.: 12.3E+5

NL: carriage key, integer: 10

^END: EOI signal in IEEE-488

Subsystem commands of this series of instruments:

- DISPlay
- ORESister
- TRIGger
- CORRection
- FREQuency
- BIAS
- INITiate
- COMParator
- VOLTage
- FUNCTion
- FETCh?
- Mass MEMory
- CURRent
- LIST
- ABORT
- TRAN
- AMPLitude
- APERture

●STATUS

9.2.1 DISPLAY subsystem commands

◆ Description: Control page switching

Command syntax:

:DISP:PAGE?

:DISP:PAGE <PageName>

Parameter: the meaning of the value of PageName is shown in the following table 10-1:

PageName	Meaning	Query return content
MEASurement	Measurement display	MEASurement
LIST	List display	LIST
TSMEas	Trace sweep display	TSMEas
MSETup	Measurement setup	MSETup
LTABLE	Limit setup	LTABLE
LSETup	List setup	LSETup
TSSETup	Trace setup	TSSETup
CSETup	Correction setup	CSETup
SYSTem	System setup	SYSTem
FLISt	File list	FLISt
TMDisp	Transformer single group measurement display	TMDisp
TTSet	Transformer single group measurement setup	TTSet
TSDisp	Transformer scan test page	TSDisp
TSID	Transformer scan ID page	TSID
TSP2P	Transformer pin to fixture page	TSP2P
TSPTO1831		TSPTO1831
TSPTO1901		TSPTO1901
TSP	Transformer pin page	TSP
TSCON	Transformer test condition page	TSCON
TSDEV	Transformer deviation deduction page	TSDEV
TSCOPY	Transformer quick setup	TSCOPY
TSSTAT	Transformer statistics page	TSSTAT

TSTOOL	Transformer tool page	TSTOOL
TSBOXSELF	Scan and Self-Test page	TSBOXSELF
TSHAND	Transformer sorting setup	TSHAND
Table 9-1 Meaning description of PageName		

Example:

:DISP:PAGE MEAS ----Enter the measurement display page;

:DISP:PAGE MSET ----Enter the measurement setup page;

:DISP:PAGE? ----Return to the currently displayed page, please refer to the table above.

9.2.2 FREQuency subsystem commands

◆ Description: Used to set the measurement frequency of the instrument

Command syntax:

:FREQ?

:FREQ <float | MIN | MAX>

Parameter:

float ---- Represent the floating-point data

MIN ---- Set the minimum settable value

MAX ---- Set the maximum settable value

Example:

:FREQ 1200 ---- Set the frequency to 1200Hz;

:FREQ 1200HZ ---- Set the frequency to 1200Hz;

:FREQ 1.2K ---- Set the frequency to 1200Hz;

:FREQ? ---- Return the current frequency.

9.2.3 VOLTage subsystem commands

9.2.3.1 AC Voltage

◆ Description: Used to set the AC voltage of the instrument

Command syntax:

:VOLT? :VOLT <float | MIN | MAX>

Parameter:

float ---- Represent the floating-point data

MIN ---- Set the minimum settable value

MAX ---- Set the maximum settable value

Example:

:VOLT 1.2 ----Set the AC voltage to 1.2V;

:VOLT? ----Return the current AC voltage;

9.2.3.2 DC Voltage

◆ Description: Used to set the DC voltage of the instrument

Command syntax:

:VOLT:DC?

:VOLT:DC < float | MIN | MAX>

Parameter:

float ---- Represent the floating-point data

MIN ---- Set the minimum settable value

MAX ---- Set the maximum settable value

Example:

:VOLT:DC 1.2 ----Set the DC voltage to 1.2V;

:VOLT:DC? ----Return the current DC voltage

9.2.4 CURRent subsystem commands

◆ Description: Used to set the measurement level current of the instrument

Command syntax:

:CURR?

:CURR < float | MIN | MAX>

Parameter:

float ---- Represent the floating-point data

MIN ---- Set the minimum settable value

MAX ---- Set the maximum settable value

Example:

:CURR 0.01 ----Set the measurement level to 10mA;

:CURR? ----Return the current level current;

9.2.5 AMPLitude subsystem commands

◆ Description: Set the measurement speed and average times of the instrument

Command systax:

:APER?

:APER <FAST+ | FAST | MED | SLOW>[,int]

Parameter:

FAST+ ----Fast+

FAST - Fast

MED----Medium

SLOW ---- Slow

int ---- represent the value of the integer, ranging from 1 to 255

Example:

:APER FAST+ ----Set the test speed to fast+

:APER FAST ---- Set the test speed to fast

:APER MED ---- Set the test speed to medium
:APER SLOW ---- Set the test speed to slow
:APER FAST,2 ----Set the test speed to fast, and average 2 times

9.2.6 OUTPut subsystem commands

9.2.6.1 Bias source

◆ Description: Set the DC bias source of the instrument

Command syntax:

:OUTP:HPOW?

:OUTP:HPOW <INT | OPT | EXT>

Parameter:

INT ---- Internal 100mA bias current source

OPT ---- Internal 2A bias current source

EXT ---- external bias current source

Example:

:OUTP:HPOW INT ----Set the internal 100mA bias current source

:OUTP:HPOW OPT ----Set the internal 2A bias current source

:OUTP:HPOW EXT ----Set the external bias current source

:OUTP:HPOW? ----Return to bias current source mode

9.2.6.2 DCI isolation

◆ Description: Set the DC isolation function switch of the instrument

Command syntax:

:OUTP:DC:ISOL?

:OUTP:DC:ISOL <0|1|ON|OFF >

Parameter:

0|OFF ---- OFF

1|ON ---- ON

Example:

:OUTP:DC:ISOL 0 ----Turn off the DC isolation function

:OUTP:DC:ISOL 1 ----Turn on the DC isolation function

:OUTP:DC:ISOL? ----Returns the switch status of the DC isolation function

9.2.7 BIAS subsystem commands

The :BIAS subsystem commands are mainly used to set the internal bias voltage and the bias status.

9.2.7.1 Status switch

◆ Description: Set the bias switch of the instrument

Command systax:

:BIAS:STAT?

:BIAS:STAT <0|1|ON|OFF >

Parameter:

0|OFF ---- off

1|ON ---- on

Example:

:BIAS:STAT 0 ----Turn off the DC bias

:BIAS:STAT 1 ----Turn on the DC bias

:BIAS:STAT? ----Return the DC bias switch status

9.2.7.2 Bias voltage

◆ Description: Set the internal bias voltage of the instrument

Command systax:

:BIAS:VOLT?

:BIAS:VOLT <float | MIN | MAX>

Parameter:

float ---- Represent the floating-point data

MIN ---- Set the minimum settable value

MAX ---- Set the maximum settable value

Example:

:BIAS:VOLT 1.2 ----Set the DC bias voltage to 1.2V;

:BIAS:VOLT? ----Return the current DC bias voltage

9.2.7.3 Bias current

◆ Description: Used to set the bias current of the instrument

Command systax:

:BIAS:CURR?

:BIAS:CURR < float | MIN | MAX>

Parameter:

float ---- Represent the floating-point data

MIN ---- Set the minimum settable value

MAX ---- Set the maximum settable value

Example:

:BIAS:CURR 0.01 ----Set the bias current to 10mA;

:BIAS:CURR? ----Return the current bias current

9.2.7.4 Bias polarity

◆ Description: Set the bias polarity of the instrument

Command syntax:

:BIAS:POL:AUTO?

:BIAS:POL:AUTO<0|1|AUTO|FIX >

Parameter:

0|AUTO ----AUTO

1|FIX----FIX

Example:

:BIAS:POL:AUTO 0 ----Set the bias polarity to AUTO

:BIAS:POL:AUTO 1 ----Set the bias polarity to FIX

:BIAS:POL:AUTO? ----Return to bias polarity status

9.2.8 TRIGger subsystem commands

The TRIGger subsystem commands are mainly used to set the instrument trigger source, trigger delay and trigger measurement.

◆ Description: Trigger the instrument to measure once

Command syntax:

:TRIG

Parameter:

Example:

:TRIG ---- Trigger the instrument to measure once

9.2.8.1 Trigger mode

◆ Description: Set the trigger source mode of the instrument

Command syntax:

:TRIG:SOUR?

:TRIG:SOUR<CONT | SING>

Parameter:

:CONT ----Continuous

:SING ----Single

Example:

:TRIG:SOUR CONT ----Set to continuous trigger

:TRIG:SOUR SING ----Set to single trigger

:TRIG:SOUR? ----Return to the trigger mode

9.2.8.2 Trigger delay

◆ Description: Set the trigger delay time of the instrument

Command syntax:

:TRIG:DEL?

:TRIG:DEL<float | MIN | MAX>

Parameter:

float ---- Represent the floating-point data

MIN ---- Set the minimum settable value

MAX ---- Set the maximum settable value

Example:

:TRIG:DEL 0 ----Set the trigger delay to 0;

:TRIG:DEL 1ms ----Set the trigger delay to 1ms;

:TRIG:DEL 1 ----Set the trigger delay to 1s;

:TRIG:DEL? ----Return the trigger delay value

9.2.8.3 Trigger Status Query

◆ Description: Get the trigger status of the instrument

Command Syntax:

:TRIGger:STATus?

Parameters:

Returns RUN 0/1;

RUN 0---- means idle or end of test;

R UN 1---- means the test is running and has not yet finished;

Example:

:TRIG:STAT? //Returns RUN 0 or RUN 1 (return immediately)

Note: This instruction applies to test Note: This instruction applies to the case where the test time is long and the host computer does not know the waiting time, it can constantly detect this state, and after the state becomes 0, query the test results, and it will surely get the value of the test results immediately.

9.2.8.4 Trigger Reset

◆ Description: Equivalent to the panel reset button, set the pause or end of the instrument

Syntax:

:TRIGger:ReSet

ReSet parameter:

Example:

:TRIG:RST?

Remarks: Sets the pause or end of the instrument.

9.2.9 AMPLitude Auto Level subsystem commands

◆ Description: Used to set the automatic level control (ALC) switch of the instrument

Command systax:

:AMPL:ALC?

:AMPL:ALC<0|1|ON|OFF>

Parameter:

0|OFF ---- OFF

1|ON ---- ON

Example:

:AMPL:ALC 0 ---- Turn off the automatic level control function

:AMPL:ALC 1 ----Turn on the automatic level control function

:AMPL:ALC? ----Return to automatic level control state

9.2.10 Output RESister Internal Resistance subsystem commands

◆ Description: Set the output resistance mode of the instrument

Command syntax:

:ORES?

:ORES<100|30>

Parameter:

100 ----Set the output resistance of the instrument to 100Ω

30 ---- Set the output resistance of the instrument to 30Ω

Example:

:ORES 100 ----Set the output resistance of the instrument to 100Ω

:ORES 30 ----Set the output resistance of the instrument to 30Ω

:ORES? ----Return the output internal resistance of the instrument

9.2.11 FUNCTION subsystem commands

The FUNCTION subsystem commands are mainly used to set measurement functions, range, current/voltage monitor ON/OFF, deviation display mode, nominal setting.

9.2.11.1 Function parameter

◆ Description: Set the "function" parameters of the instrument

Command syntax:

:FUNC:IMP[1|2|3|4]?

:FUNC:IMP <para1,para2,para3,para4>

:FUNC:IMP<1|2|3|4> <para>

:FUNC:IMPSW <0|1>,<0|1>,<0|1>,<0|1>

:FUNC:IMPSW?

Parameter:

para1,para2,para3,para4 ----Indicate the optional function parameter name, the value is as follows:

Parameter name	Parameter meaning	Parameter name	Parameter meaning
CP	Equivalent parallel capacitance	CS	Equivalent series capacitance

LP	Equivalent parallel inductance	LS	Equivalent series inductance
RP	Equivalent parallel resistance	RS	Equivalent series resistance
GP	Conductance	BP	Susceptance
Z	Absolute value of impedance	Y	Absolute value of admittance
D	Loss factor	Q	Quality factor
ZTD/DZ	θ_z° Impedance degree	ZTR/RZ	θ_z Impedance radian
YTD/DY	θ_y° Admittance degree	YTR/RY	θ_y Admittance radian
X	Reactance	RD	DC Resistance

Example:

:FUNC:IMP CP,CS,LP,LS ----Set 4 parameter functions at the same time

:FUNC:IMP1 RP ----Set parameter 1 to RP

:FUNC:IMP2 RS ----Set parameter 1 to RS

:FUNC:IMP3 Z ----Set parameter 1 to Z

:FUNC:IMP4 Y ----Set parameter 1 to Y

:FUNC:IMP1? ----Query the function of parameter 1

:FUNC:IMP2? ---- Query the function of parameter 2

:FUNC:IMP3? ---- Query the function of parameter 3

:FUNC:IMP4? ---- Query the function of parameter 4

:FUNC:IMP? ---- Query the functions of the 4 parameters

:FUNC:IMPSW 1,1,0,0 ---- Set the switches of 4 parameter (on, on, off, off)

:FUNC:IMPSW 1,0,0,0 ---- Set the switches of 4 parameter (on, off, off, off)

:FUNC:IMPSW 1,1,1,1 ---- Set the switches of 4 parameter (on, on, on, on)

:FUNC:IMPSW? ---- Query the switches of 4 parameter (returns such as "1,0,0,0")

9.2.11.2 AC Range

◆ Description: Set the AC range of the instrument

Command syntax:

:FUNC:IMP:RANG?

:FUNC:IMP:RANG <float>

Parameter:

float ---- Indicates the floating point number, refer to the value of the equivalent resistance of the DUT

Example:

:FUNC:IMP:RANG 1k ----Select the best range for 1k Ω equivalent resistance

:FUNC:IMP:RANG 1000 ----Select the best range for 1k Ω equivalent resistance

:FUNC:IMP:RANG 1200 ----Select the best range for 1.2k Ω equivalent resistance

:FUNC:IMP:RANG? ----Return to the current AC range

◆ Description: Set the range of the instrument to AUTO

Command syntax:

:FUNC:IMP:RANG:AUTO?
:FUNC:IMP:RANG:AUTO <0 | 1 | OFF | ON>
Parameter:
0|OFF ---- OFF
1|ON ---- ON
Example:
:FUNC:IMP:RANG:AUTO 0 ----Set the AC range to FIX
:FUNC:IMP:RANG:AUTO 1 ----Set the AC range to AUTO
:FUNC:IMP:RANG:AUTO? ----Return to automatic state of AC range

9.2.11.3 DC range

◆ Description: Set the DC range of the instrument
Command syntax:
:FUNC:DCR:RANG?
:FUNC:DCR:RANG <float>
Parameter:
float ---- Indicates the floating point number, refer to the value of the equivalent resistance of the DUT
Example:
:FUNC:DCR:RANG 1k ----Select the best range for 1kΩDCR
:FUNC:DCR:RANG 1000 ----Select the best range for 1kΩDCR
:FUNC:DCR:RANG 1200 ----Select the best range for 1.2kΩDCR
:FUNC:DCR:RANG? ----Return to the current DC range

9.2.11.4 VI Monitoring

◆ Description: Set the voltage monitoring switch of the instrument
Command syntax:
:FUNC:SMON:VAC?
:FUNC:SMON:VAC <0 | 1 | OFF | ON>
Parameter:
0|OFF ---- OFF
1|ON ---- ON
Example:
:FUNC:SMON:VAC 0 ----Turn off voltage monitoring
:FUNC:SMON:VAC 1 ----Turn on voltage monitoring
:FUNC:SMON:VAC? ----Return the voltage monitoring switch status

◆ Description: Set the current monitoring switch of the instrument
Command syntax:
:FUNC:SMON:IAC?
:FUNC:SMON:IAC <0 | 1 | OFF | ON>
Parameter:
0|OFF ---- OFF

1|ON ---- ON

Example:

:FUNC:SMON:IAC 0 ---- Turn off current monitoring

:FUNC:SMON:IAC 1 ----Turn on current monitoring

:FUNC:SMON:IAC? ----Return the current monitoring switch status

9.2.11.5 Deviation and Reference

◆ Description: Set the deviation measurement mode of the instrument

Command systax:

:FUNC:DEV[1|2|3|4]:MODE?

:FUNC:DEV[1|2|3|4]:MODE <ABS|PER|OFF>

Parameter:

ABS---- Δ Absolute deviation

PER ---- $\Delta\%$ percent deviation

OFF ---- off

Example:

:FUNC:DEV1:MODE ABS ----Set parameter 1to absolute deviation

:FUNC:DEV2:MODE PER ----Set parameter 2 to percentage deviation

:FUNC:DEV3:MODE OFF ----Turn off the deviation mode of parameter 3

:FUNC:DEV:MODE OFF,PER,ABS,OFF ----Set the deviation modes of 4-parameters at the same time

:FUNC:DEV2:MODE? ---- Return to the deviation mode of parameter 2

:FUNC:DEV:MODE? ---- Return to the deviation modes of 4-parameters

◆ Description: Set the reference value of the deviation of the instrument

Command systax:

:FUNC:DEV[1|2|3|4]:REF?

:FUNC:DEV[1|2|3|4]:REF <float>

:FUNC:DEV<1|2|3|4>:REF:FILL

Parameter:

float ---- represents the floating-point data

Example:

:FUNC:DEV1:REF 10 ----Set the deviation reference of parameter 1 to 10

:FUNC:DEV2:REF:FILL ----Measure once, the result of parameter 2 is used as the deviation reference value

:FUNC:DEV4:REF? ----Return to the deviation reference value of parameter 4

:FUNC:DEV:REF? ----Return to the deviation reference values of 4 parameters

:FUNC:DEV:REF 10,11,12,13 ----Set the deviation reference values of the 4-parameters at the same time

9.2.11.6 Step Delay

◆ Description: Set the instrument step delay time

Command systax:

:FUNC:SDEL?
:FUNC:SDEL<float | MIN | MAX>

Parameter:

float ---- Represents the floating-point data

MIN ---- Set the minimum settable value

MAX ---- Set the maximum settable value

Example:

:FUNC:SDEL 0 ----Set the step delay to 0;

:FUNC:SDEL 1ms ----Set the step delay to 1ms;

:FUNC:SDEL 1 ----Set the step delay to 1s;

:FUNC:SDEL? ----Return the step delay value;

9.2.12 COMParator subsystem commands

The COMParator subsystem commands are used to set the bin comparator function, including the setting of the comparison switch and the setting of the limit list.

9.2.12.1 COMP comparison switch

◆ Description: Set the instrument comparison function on or off

Command systax:

:COMP? :COMP<0|1|ON|OFF >

Parameter:

0|OFF ---- OFF

1|ON ---- ON

Example:

:COMP 0 ---- Set the comparison function to OFF

:COMP 1 ---- Set the comparison function to ON

:COMP? ----Return to compare function switch status

9.2.12.2 COUNT count switch

◆ Description: Set the instrument comparison counting function ON or OFF

Command systax:

:COMP:COUNT?

:COMP:COUN<0|1|ON|OFF >

Parameter:

0|OFF ---- OFF

1|ON ---- ON

Example:

:COMP:COUN 0 ----Set the comparison count function to OFF

:COMP:COUN 1 ----Set the comparison count function to ON

:COMP:COUN? ----Return to the switch status of the compare count function

◆ Description: Query the bin count comparison result

Command syntax:

:COMP:COUN:DATA?

Parameter:

Example:

:COMP:COUN:DATA? ----Return the count result of each bin

◆ Description: Clear all bin count results

Command syntax:

:COMP:COUN:CLE

Parameter:

Example:

:COMP:COUN: CLE ----Clear all count results

9.2.12.3 MODE Limit mode

◆ Description: Set the instrument comparison limit mode

Command syntax:

:COMP:MODE?

:COMP:MODE<TOL|SEQ>

Parameter:

TOL ---- Tolerance mode

SEQ ---- Continue mode

Example:

:COMP:MODE TOL ----Set the comparison limit to tolerance mode

:COMP:MODE SEQ ----Set the comparison limit to continue mode

:COMP:MODE? ----Return to compare limit mode

9.2.12.4 TOL:BIN Limit value

◆ Description: Set the upper and lower limit values of each bin in the error mode of the comparison function (this function is valid when the limit mode is set to error mode). You can query the upper and lower limit values of each bin.

Command syntax:

:COMP:TOL:BIN<n>?

:COMP:TOL:BIN<n><lowA,highA>[...][,lowD,highD]

Parameter:

n ---- Bin number index, the value is 1~10

lowA ---- Represent the floating-point number of low limit of parameter 1

highA ---- Represent the floating-point number of high limit of parameter 1

lowD ---- Represent the floating-point number of low limit of parameter 4

highD ---- Represent the floating-point number of high limit of parameter 4

Example:

:COMP:TOL:BIN11,2 ----Set the upper and lower limits of the first parameter of bin 1 to [1,2];

:COMP:TOL:BIN31,2,3,4 ----Set the upper and lower limits of the first two parameters of bin 3 to

[1,2],[3,4];

:COMP:TOL:BIN101, 2, 3, 4, 5, 6, 7, 8 ---- Set the upper and lower limits of 4 parameters of 10 bins;

:COMP:TOL:BIN1? ---- Returns the upper and lower limits corresponding to the 4 parameters of bin 1.

9.2.12.5 SEQ:BIN Limit Value

- ◆ Description: Set the upper and lower limit data of the continuous mode of the comparison function (this function is valid when the limit mode is set to continuous mode). You can query the upper and lower limit values of each bin.

Command syntax:

:COMP:SEQ:BIN[A|B|C|D]?

:COMP:SEQ:BIN[A|B|C|D] <lo1>[,hi1,hi2,...hi10]

Parameter:

A|B|C|D ---- Indicate the corresponding number of parameters in the 4 parameters,

lo1 ---- The floating point data of the lower limit of bin 1

hi1...hi10 ---- The floating-point numbers of the upper limit of each bin

Example:

:COMP:SEQ:BIN1,2,3,4,5----Set the first parameter lo1,hi1,hi2,hi3,hi4;

:COMP:SEQ:BIN1A1,2,3,4,5---- Same as above;

:COMP:SEQ:BIN1B1,2,3,4,5,6 ----Set the second parameter lo1,hi1,hi2,hi3,hi4,hi5;

:COMP:SEQ:BIN1C1,2,3,4,5,6,7,8,9,10,11----Set the upper and lower limits of the third parameter of each bin;

:COMP:SEQ:BIN1? ---- Return to the upper and lower limits of parameter 1, bin 1 and the upper limits of other bins;

:COMP:SEQ:BIN1A? ---- Same as above

:COMP:SEQ:BIN1B? ---- Return to the upper and lower limits of parameter 2, bin 1, and the upper limits of other bins;

:COMP:SEQ:BIN1C? ---- Return to the upper and lower limits of parameter 3, bin 1 and the upper limits of otherbins;

:COMP:SEQ:BIN1D? ---- Return to the upper and lower limits of parameter 4, bin 1 and the upper limits of other bins.

9.2.12.6 CLRar Clear Table

- ◆ Description: Used to clear the limit setting data of each bin.

Command syntax:

:COMP:BIN:CLE

Parameter:

Example:

:COMP:BIN:CLE ----Clear the limit data in the table

9.2.12.7 BIN:SW Bin switch

◆ Description: Set the specified bin comparison function to on or off.

Command syntax:

:COMP:BIN<n>:SW?

:COMP:BIN:SW<0|1|ON|OFF >

Parameter:

n ---- bin number index, the value is 1~10

0|OFF ---- OFF

1|ON ---- ON

Example:

:COMP:BIN1:SW 0 ---- Set the comparison function of bin 1 to OFF

:COMP:BIN2:SW 1 ----Set the comparison function of bin 2 to ON

:COMP:BIN10:SW? ----Return to BIN10 comparison function switch status.

9.2.13 LIST subsystem commands

The LIST subsystem commands are mainly used to set the list sweep function, sweep points, sweep mode, sweep limits.

9.2.13.1 TOTAL sweep points

◆ Description: Set the total number of scan points in the list

Command syntax:

:LIST:TOTAL?

:LIST:TOTAL <int>

Parameter:

int ----The total number of scan points, the value is 1~201

Example:

:LIST:TOTAL 8 ----Set the list sweep points to 8

:LIST:TOTAL 201 ----Set the list sweep points to 201

:LIST:TOTAL? ---- Return to the number of sweep points in the list

9.2.13.2 List mode

◆ Description: Set the instrument list sweep mode

Command syntax:

:LIST:MODE?

:LIST:MODE<SEQ | STEP>

Parameter:

SEQ ---- continuous

STEP ----Single step

Example:

:LIST:MODE SEQ ----Set to continue mode
:LIST:MODE STEP ----Set the step mode
:LIST:MODE? ----Return to list sweep mode

9.2.13.3 COMP Compare Switch

◆ Description: Set the Compare List Scan function switch

Command syntax:

:LIST:COMP?

:LIST:COMP <0|1|ON|OFF>.

Parameters:

0|OFF ---- OFF

1|ON ---- ON

Example:

:LIST:COMP 0 ---- Set list scan compare function ON

:LIST:COMP OFF ---- Set List Scan Compare Function OFF

:LIST:COMP? ---- Query list scan compare function current status

9.2.13.4 LISTDELTA Difference Mode

◆ Description: Set list scan parameter 1 difference mode switch

Command syntax:

:LISTDELTA:SWITCH?

:LISTDELTA:SWitch <0|1|ON|OFF>.

Parameter:

0|OFF ---- off

1|ON ---- on

Example:

:LISTDELTA:SWitch 0 ---- set list scan interpolation mode on

: LISTDELTA:SWitch OFF ---- set list scan interpolation mode off

:LISTDELTA:SWitch? ---- Queries the current status of the list scan interpolation mode

◆ Description: Sets the difference mode of parameter 1 of each scan point when the list scan interpolation mode is on.

Command syntax:

:LISTDELTA:MODE[n]?

:LISTDELTA:MODE[n] <mode>.

Parameter: <n> take value 1~201 (total number of scanned points)

<mode> take value 0, 1, 2, 3, 4, 5, 6, 7, 8, 9

0 ---- Mode(Pn-P1)

1 ---- Mode(Pn-P1)/P1

2 ---- Mode(Pn-P1)/P1*100% 3 ---- Mode(Pn-P1)/P1

3 ---- Mode(Pn-P1)/Pn

4 ---- Mode(Pn-P1)/Pn*100% 5 ---- Mode(Pn-P1)/Pn

5 ---- Mode(Pn)

6 ---- Mode(Pn-P2)/P2
7 ---- Mode(Pn-P2)/P2*100% 8 ---- Mode(Pn-P2)/P2
8 ---- Mode(Pn-P2)/Pn
9 ---- Mode(Pn-P2)/Pn*100%.

Examples:

: LISTDELTA:MODE2 0 ---- Sets the list scan interpolation mode on and the difference mode of scan point 2 is (Pn-P1), i.e., P2-P1.

:LISTDELTA:MODE2? ---- Queries the current interpolation mode of list scan point 2

◆ Description: Sets the lower limit of the difference corresponding to the interpolation mode of the scan point when the list scan interpolation mode is on.

Command syntax:

:LISTDELTA:LOW[n]?

:LISTDELTA:LOW[n] <value

Parameter: <n> take value 3~201 (total number of scanned points)

<value> Take value type NR3

Example:

:LISTDELTA:MODE3 0 ---- Set the list scan interpolation mode on and the difference mode of scan point 3 is (Pn-P1) i.e. P3-P1.

:LISTDELTA :LOW3 -1 ---- Based on the previous command, set the list scan interpolation mode on, and the difference mode of scan point 3 is (P3-P1), and the lower limit of this difference is -1, and its unit is the same as that of parameter 1.

:LISTDELTA:LOW3? ---- Reads the lower limit of the current interpolation mode of list scan point 3

◆ Description: Sets the lower limit of the difference that corresponds to the interpolation mode of the scan point when the interpolation mode of the list scan is on mode is on, sets the upper limit of the difference that corresponds to the interpolation mode of the scan point.

Command syntax:

:LISTDELTA:HIGH[n]?

:LISTDELTA:HIGH[n] <value

Parameter: <n> take value 1~201 (total number of sampled points)

<value> take value type NR3

Example:

:LISTDELTA:MODE3 0 ---- Sets the list scan interpolation mode to ON and the difference mode of scan point 3 to (Pn-P1), i.e. P3-P1.

:LISTDELTA: HIGH [n]? LISTDELTA:HIGH3 10 ---- Based on the previous command, the list scan interpolation mode is turned on, and the difference mode of scan point 3 is (P3-P1), and the lower limit of this difference is 10, and its unit is the same as that of parameter 1.

:LISTDELTA:HIGH3? ---- Reads the upper limit of the current interpolation mode of list scan point 3.

9.2.13.5 DISP Parameter Display Switches

◆ Description: Set list scan parameter display switch 4

Command syntax:

:LIST:DISP:PARA?

:LIST:DISP:PARA <0|1>,<0|1>,<0|1>,<0|1>,<0|1>,<0|1>

Parameters:

0|OFF ---- means turn off the display, i.e. do not display, save or report the data.

1|ON ---- means to turn on the display

Example:

:LIST. DISP:PARA 1,0,0,0 ---- sets the parameters of list 4 to turn on only the first one.

:LIST:DISP:PARA 1,1,0,0 ---- sets the list 4 parameters to turn on only the first two.

:LIST:DISP:PARA? ---- queries the list 4 parameters to display the open status

◆ Description: sets the list scan frequency display switch

Command syntax:

:LIST. DISP:FREQ?

:LIST:DISP:FREQ <0|1>.

Parameters:

0|OFF ---- means display off

1|ON ---- means display on

Example:

:LIST:DISP:FREQ 1 ---- sets list frequency display on

:LIST:DISP:FREQ 0 ---- switches list frequency display off

:LIST. :DISP:FREQ? ---- queries list frequency display on status

◆ Description: Set List Scan AC Level Display Switch

Command syntax:

:LIST:DISP:ACLV?

:LIST:DISP:ACLV <0|1>.

Parameters:

0|OFF ---- means off display

1|ON ---- means on display

Example:

:LIST:DISP. ACLV 1 ---- switches the display of the list AC level on

:LIST:DISP:ACLV 0 ---- turns off the list AC level display.

:LIST:DISP:ACLV? ---- queries list AC level display on status

◆ Description: sets the list scan bias display switch

Command syntax:

:LIST:DISP:BIAS?

:LIST. DISP:BIAS <0|1>.

Parameter:

0|OFF ---- means display off

1|ON ---- means display on

Example:

:LIST:DISP:BIAS 1 ---- sets list bias display on

:LIST:DISP:BIAS 0 ---- turns list bias display off

:LIST:DISP:BIAS? ---- To query the list bias display on status

9.2.13.6 CLEar

- ◆ Description: Clear the setting data of all sweep points

Command syntax:

:LIST:CLE [n|ALL]

Parameter:

n ---- Specify the corresponding point of the list, the value is 1~201

ALL ---- Specify all points in the list

Example:

:LIST:CLE ----Clear the setting data of all sweep points

:LIST:CLE ALL ----Clear the setting data of all sweep points

:LIST:CLE 5 ----Clear the setting data of point 5

9.2.13.7 FREQuency

- ◆ Description: Set the sweep point frequency, set the frequency of several points starting from the nth point

Command syntax:

:LIST:FREQ[n]?

:LIST:FREQ[n] <fn>[,fn+1][,fn+2]...

Parameter:

n ---- Start from the nth point

f_n ---- The floating-point number of swep point n

f_{n+1} ---- The floating-point number of swep point n+1

f_{n+2} ---- The floating-point number of swep point n+2

f... ---- The floating-point number of swep point ...

Example:

:LIST:FREQ 20,30,40 ----Set the frequency of the first 3 points;

:LIST:FREQ1 20,30,40,1k,2k ---- Set the frequency of the first 5 points;

:LIST:FREQ6 20, 30, 40, 1k, 2k ---- set the frequency of 6~10 points;

:LIST:FREQ25 20k ---- Set the frequency of the 25th point;

:LIST:FREQ? ----Return the frequency of all sweep points;

:LIST:FREQ4? ---- Returns the frequency of point 4.

9.2.13.8 VOLTage

- ◆ Description: Set the sweep point test level, set the voltage of several points starting from the nth point

Command syntax:

:LIST:VOLT[n]?

:LIST:VOLT[n] <fn>[,fn+1][,fn+2]...

Parameter:

n ---- start from the nth point

f_n ---- The floating-point number of sweep point n
 f_{n+1} ---- The floating-point number of sweep point n+1
 f_{n+2} ---- The floating-point number of sweep point n+2
 $f...$ ---- The floating-point number of sweep point n...

Example:

:LIST:VOLT 1,2,3 ---- Set the voltage of the first 3 points;
:LIST:VOLT 1,2,3,4,2 ---- set the voltage of the first 5 points;
:LIST:VOLT6 1,2,3,4,5 ---- set the voltage of 6~10 points;
:LIST:VOLT25 20 ---- Set the voltage of the 25th point;
:LIST:VOLT? ----Return to the voltage of all sweep points;
:LIST:VOLT4? ----Return to the voltage of point 4;

9.2.13.9 CURRent

◆ Description: Set the sweep point test level, set the current value of several points starting from the nth point

Command systax:

:LIST:CURR[n]?
:LIST:CURR[n] <fn>[,fn+1][,fn+2]...

Parameter:

n ---- start from the nth point
 f_n ---- The floating-point number of sweep point n
 f_{n+1} ---- The floating-point number of sweep point n+1
 f_{n+2} ---- The floating-point number of sweep point n+2
 $f...$ ---- The floating-point number of sweep point n...

Example:

:LIST:CURR 0.01, 20m, 30m ---- Set the current of the first 3 points;
:LIST:CURR 1m, 2m, 3m, 4m, 2m ---- Set the current of the first 5 points;
:LIST:CURR6 1m, 2m, 3m, 4m, 5m----Set the current of 6~10 points;
:LIST:CURR25 20m ---- Set the current of the 25th point;
:LIST:CURR? ----Return to the current of all sweep points;
:LIST:CURR4? ----Return to the current of point 4;

9.2.13.10 Bias voltage

◆ Description: Set the sweep point bias voltage, set the bias voltage of several points starting from the nth point

Command systax:

:LIST:BIAS:VOLT[n]?
:LIST:BIAS:VOLT[n] <fn>[,fn+1][,fn+2]...

Parameter:

n ---- start from the nth point
 f_n ---- The floating-point number of sweep point n
 f_{n+1} ---- The floating-point number of sweep point n+1

fn+2 ---- The floating-point number of swep point n+2

f... ---- The floating-point number of swep point n...

Example:

:LIST:BIAS:VOLT 1,2,3 ----Set the bias voltage of the first 3 points;

:LIST:BIAS:VOLT6 1,2,3,4,5----Set the bias voltage of 6~10 points;

:LIST:BIAS:VOLT? ----Return to the bias voltage of all sweep points;

:LIST:BIAS:VOLT4? ----Return to the bias voltage of point 4;

9.2.13.11 Bias current

◆ Description: Set the sweep point bias current, set the bias current of several points starting from the nth point

Command systax:

:LIST:BIAS:CURR[n]?

:LIST:BIAS:CURR[n] <fn>[,fn+1][,fn+2]...

Parameter:

n ---- start from the nth point

fn ---- The floating-point number of swep point n

fn+1 ---- The floating-point number of swep point n+1

fn+2 ---- The floating-point number of swep point n+2

f... ---- The floating-point number of swep point n...

Example:

:LIST:BIAS:CURR 1m, 2m, 3m ----Set the bias current of the first 3 points;

:LIST:BIAS:CURR6 1m, 2m, 3m, 4m, 5m ---- Set the bias current of 6~10 points;

:LIST:BIAS:CURR? ----Return to the bias current of all points;

:LIST:BIAS:CURR4? ----Return to the bias current of point 4;

9.2.13.12 FUNCtion parameter function

◆ Description: Set the "function" parameter of the specified point of the list sweep

Command systax:

:LIST:FUNC:IMP<n>?

:LIST:FUNC:IMP<n><para1,para2,para3,para4>

Parameter:

n---- Specify the index of the sweep point, ranging from 1 to 201

para1,para2,para3,para4 ----Indicate the optional function parameter name, the value is as follows:

Parameter name	Parameter meaning	Parameter name	Parameter meaning
CP	Equivalent parallel capacitance	CS	Equivalent series capacitance
LP	Equivalent parallel inductance	LS	Equivalent series inductance
RP	Equivalent parallel	RS	Equivalent series

	resistance		resistance
GP	Conductance	BP	Susceptance
Z	Absolute value of impedance	Y	Absolute value of admittance
D	Loss factor	Q	Quality factor
ZTD/DZ	θ_z° Impedance degree	ZTR/RZ	θ_z Impedance radian
YTD/DY	θ_y° Admittance degree	YTR/RY	θ_y Admittance radian
X	Reactance	RD	DC Resistance

Example:

:LIST:FUNC:IMP1 CP,CS,LP,LS ----Set the 4 parameter functions of point 1

:LIST:FUNC:IMP5 CP,CS,LP,LS ----Set the 4 parameter functions of point 5

:LIST:FUNC:IMP100 CP,CS,LP,LS----Set the 4 parameter functions of the 100th point

:LIST:FUNC:IMP1? ----Return to the 4-parameter functions of point 1

◆ Description: Set the function of list sweep specified parameters, the function of several points starting from the nth point

Command systax:

:LIST:FUNC:IMP<A|B|C|D><n>?

:LIST:FUNC:IMP<A|B|C|D><n><pn>[,pn+1,pn+2,pn+3...]

Parameter:

A|B|C|D ---- Indicate that one of the 4 parameters is specified

n ---- Specify the index of the sweep point, ranging from 1 to 201

p_n ---- The function name of sweep point n, (refer to the table above)

p_{n+1} ---- The function name of sweep point n+1

p_{n+2} ---- The function name of sweep point n+2

$p_{...}$ ---- The function name of sweep point n...

Example:

:LIST:FUNC:IMPA CP,CS,LP ----Set the parameter function of point 1~3 of the first parameter

:LIST:FUNC:IMPB5 CP,CS ----Set the parameter function of point 5~6 of the second parameter

:LIST:FUNC:IMPC? ----Return to all point parameter functions of the third parameter

:LIST:FUNC:IMPD11? ---- Return to the parameter function of the 11th point of the fourth parameter.

◆ Description: Linear setting of the specified parameter

Command systax:

:LIST:FUNC:LIN<A|B|C|D><start,stop,para>

Parameter:

A|B|C|D ---- Indicate that one of the 4 parameters is specified

start ---- Specify the starting point of the setting, the value is 1~201

stop --- Specify the end point of the setting, the value is 1~201

para ---- function name (refer to the table above)

Example:

:LIST:FUNC:LINA 1,15,LP ----Set the function of point 1~15 of the first parameter to LP

:LIST:FUNC:LINB 5,201,CP ----Set the function of point 5~201 of the second parameter to CP

:LIST:FUNC:LIND 3,15,LP ----Set the function of point 3~15 of the fourth parameter to LP

9.2.13.13 BAND Limit

◆ Description: Sets the limit data in the specified point list scan setup table

Command syntax:

:LIST:BAND<n>?

:LIST:BAND<n> OFF

:LIST:BAND<n> <A|B|C|D,lo,hi>?

Parameters:

n ---- Specifies the index of the scanned point, taking the value of 1~201.

A|B|C|D ---- indicates that one of the 4 parameters is specified.

lo ---- specifies the lower limit of the corresponding parameter of the point.

hi ---- specifies the upper limit of the corresponding parameter of the point.

Example:

:LIST:BAND1 OFF ---- clears the limits of the 4 parameters of point 1.

:LIST:BAND2 A,1,2 ---- Sets the upper and lower limits of parameter A at point 2.

:LIST:BAND201 D,1.1,2.2 ---- Sets the upper and lower limits of parameter D at point 201.

:LIST:BAND9? ---- returns the upper and lower limits of the 4 parameters at point 9 lower limit,loA,hiA...

◆ Description: Set the upper and lower limit data in the specified point list scan setup table

Command syntax:

:LIST:LOW<n> <A|B|C|D, lon> [, lon+1, lon+2....]

:LIST:HIGH<n> <A|B|C|D, hin> [, hin+1, hin+2....]

Parameters:

n ---- starts at the nth point

A|B|C|D ---- indicates one of the 4 specified parameters

lon ---- scans point n lower limit of floating point size

hin ---- scans point n upper limit of floating point size

Examples:

:LIST:LOW1 A,1,2,3,4 ---- sets the lower limit of the first 4 points of the first parameter;

:LIST:LOW1 C,1,2,3,4 ---- sets the lower limit of the first 4 points of the third parameter;

:LIST:LOW5 A,1,2,3,4 ---- sets the lower limit of the first parameter (5~8) points;

:LIST:HIGH2 A,1,2,3,4 ---- sets the high limit of the first parameter (2~5) points;

9.2.13.14 Delay

◆ Description: Set the test delay of the sweep point, set the delay time of several points starting from the nth point

Command syntax:

:LIST:DEL[n]?

:LIST:DEL[n] <fn>[,fn+1][,fn+2]...

Parameter:

n ---- Start from the nth point

f_n ---- The floating point number of the sweep point n

f_{n+1} ---- The floating point number of the sweep point $n+1$

f_{n+2} ---- The floating point number of the sweep point $n+2$

$f_{...}$ ---- The floating point number of the sweep point $n...$

Example:

:LIST:DEL 0.01, 20m, 30m ---- Set the test delay of the first 3 points;

:LIST:DEL 1m, 2m, 3m, 4m, 2m ---- Set the test delay of the first 5 points;

:LIST:DEL6 1m, 2m, 3m, 4m, 5m ---- Set the test delay of 6~10 points;

:LIST:DEL25 20m ---- Set the test delay of the 25th point;

:LIST:DEL? ----Return to the test delay of all sweep points;

:LIST:DEL4? ----Return to the test delay of point 4.

9.2.14 TRACE subsystem commands

9.2.14.1 Sweep Points

◆ Description: Set the number of LCR curve scan points

Command syntax:

:TSSE:POINT?

:TSSE:POINT <51|101|201|401|801>

Parameter:

51 ---- means scanning 51 points

101 ---- means scanning 101 points

201 ---- means scanning 201 points

401 ---- means scanning 401 points

801 ---- means scanning 801 points

Example:

:TSSE:POINT 51 ----Set LCR to scan 51 points

:TSSE:POINT 101 ----Set LCR to scan 101 points

:TSSE:POINT 201 ----Set LCR to scan 201 points

:TSSE:POINT 401 ----Set LCR to scan 401 points

:TSSE:POINT 801 ----Set LCR to scan 801 points

:TSSE:POINT? ----Query the LCR sweep points

9.2.14.2 Sweep Type

◆ Description: Set the sweep parameter type of LCR curve

Command syntax:

:TSSE:MODE?

:TSSE:MODE <FREQ|VOLT|CURR|BVOL|BCUR>

Parameter:

Enumeration type string parameter;

Example:

:TSSE:MODE FREQ ----Set the LCR sweep parameter to frequency

:TSSE:MODE VOLT ----Set the LCR sweep parameter to voltage
:TSSE:MODE CURR ----Set the LCR sweep parameter to current
:TSSE:MODE BVOL ----Set LCR sweep parameter as bias voltage
:TSSE:MODE BCUR ----Set LCR sweep parameter as bias current
:TSSE:MODE? ----Query the LCR sweep parameter type.

9.2.14.3 Sweep Range

◆ Description: Set the LCR sweep range (start and stop points)

Command syntax:

:TSSE:SWEEP?

:TSSE:SWEEP <float,float>

Parameter:

float ---- float string format, such as "3.14159";

Example:

:TSSE:SWEEP 1,100 ----Set the LCR sweep start and stop point

:TSSE:SWEEP? ----Query the LCR sweep start and stop point

9.2.14.4 Sweep Mode

◆ Description: Set the LCR sweep mode

Command syntax:

:TSSE:SMODE?

:TSSE:SMODE <SEQ|STEP>

Parameter:

SEQ ---- continuous mode

STEP ----single step mode

Example:

:TSSE:SMODE SEQ ----Set the LCR sweep mode to continuous

:TSSE:SMODE STEP ----Set the LCR sweep mode to single step

:TSSE:SWEEP? ----Query the LCR sweep mode

9.2.14.5 FORMat Mode

◆ Description: Set the LCR curve format mode

Command syntax:

:TSSE:FORMat?

:TSSE:FORMat <LIN|LOGX>

Parameter:

LIN ---- Linear coordinates

LOGX ---- X-axis logarithm

Example:

:TSSE:FORM LIN ----Set the LCR sweep coordinate as linear coordinates

:TSSE:FORM LOGX ----Set the LCR sweep coordinate as the X axis logarithm

:TSSE:FORM? ----Query the LCR sweep coordinate mode

9.2.14.6 Limit

◆ Description: Set the LCR curve limit switch

Command syntax:

:TSSE:LIMIt?

:TSSE:LIMIt <OFF|0|ON|1>

Parameter:

Example:

:TSSE:LIMI 0 ----Set the LCR sweep limit switch to OFF

:TSSE:LIMI OFF ----Set the LCR sweep limit switch to OFF

:TSSE:LIMI 1 ----Set the LCR sweep limit switch to ON

:TSSE:LIMI ON ----Set the LCR sweep limit switch to ON

:TSSE:LIMI? ----Query the LCR sweep limit switch status

9.2.14.7 Function Parameters

◆ Description: Set the LCR sweep "function" parameters

Command syntax:

:TSSE:IMP[1|2|3|4]?

:TSSE:IMP <para1,para2,para3,para4>

:TSSE:IMP<1|2|3|4> <para>

Parameter:

para1,para2,para3,para4 ----indicates the optional function parameter name, the value is as follows:

Parameter name	Parameter meaning	Parameter name	Parameter meaning
CP	Equivalent parallel capacitance	CS	Equivalent series capacitance
LP	Equivalent parallel inductance	LS	Equivalent series inductance
RP	Equivalent parallel resistance	RS	Equivalent series resistance
GP	Conductance	BP	Susceptance
Z	Absolute value of impedance	Y	Absolute value of admittance
D	Loss factor	Q	Quality factor
ZTD/DZ	θ_z° Impedance degree	ZTR/RZ	θ_z Impedance radian
YTD/DY	θ_y° Admittance degree	YTR/RY	θ_y Admittance radian
X	Reactance	RD	DC Resistance

Example:

:TSSE:IMP CP,CS,LP,LS ----Set 4 parameter functions at the same time
:TSSE:IMP1 RP ----Set parameter 1 to RP
:TSSE:IMP2 RS ----Set parameter 1 to RS
:TSSE:IMP3 Z ----Set parameter 1 to Z
:TSSE:IMP4 Y ----Set parameter 1 to Y
:TSSE:IMP1? ----Query parameter 1 function
:TSSE:IMP2? ----Query parameter 2 function
:TSSE:IMP3? ----Query parameter 3 function
:TSSE:IMP4? ----Query parameter 4 function
:TSSE:IMP? ---- Query the 4-parameter function

9.2.14.8 SCALe Auto Scaling

◆ Description: Set LCR Curve Pole Switch

Command syntax:

:TSSE:SCALE?

:TSSE:SCALE <AUTO|HOLD>.

Parameter:

Example:

:TSSE:SCALE AUTO ---- Set LCR auto-scaling to auto

:TSSE:SCALE HOLD ---- Set LCR auto-scaling to hold

:TSSE:SCALE? ---- Query LCR scanning autoscale status

9.2.14.9 ABCD Vertical Coordinate Range

◆ Description: Set the highest value of LCR curve coordinate

Command syntax:

:TSSE:<A|B|C|D>?

:TSSE:<A|B|C|D> <min,max>.

parameter:

Example:

:TSSE:A 10,1000 ---- Sets LCR scan parameter A Vertical coordinate range

:TSSE:B 10,1000 ---- Sets LCR scan parameter B vertical coordinate range

:TSSE:C 10,1000 ---- Sets LCR scan parameter C vertical coordinate range.

:TSSE:D 10,1000 ---- Sets the D vertical coordinate range of the LCR scanning parameter.

TSSE:A? ---- Query LCR scan parameter A coordinate range

TSSE:B? ---- Query LCR scan curve B coordinate range

TSSE:C? ---- query LCR scan curve C coordinate range

TSSE:D? ---- query LCR scan curve D coordinate range of LCR scan curve

9.2.14.10 SPLIt Split Screen

◆ Description: Set LCR Curve Split Screen Option

Command syntax:

:TSSE:SPLIt?

:TSSE:SPLIt <1|2|4>.

Parameter:

Example:

:TSSE:SPLI 1 ---- set LCR scan one split screen

:TSSE:SPLI 2 ---- set LCR scan two split screens

:TSSE:SPLI 4 ---- set LCR scan four split screen

:TSSE:SPLI? ---- query LCR scan split screen status

9.2.14.11 SW Curve Switch

◆ Description: Set LCR curve display switch

Command syntax:

:TSSE:SW?

:TSSE:SW[1|2|3|4] <0|1|2>[,0|1|2]...

Parameters:

SW[1|2|3|4]---- means to specify the first curve, omit means to start from the first curve.

Take the value of 0|1|2 ---- corresponds to Off, On, Maintain, Skip SW followed by Omit. Maintain; Omits the specified curve after running through SW, supports to set 4 curves on/off state at the same time.

Example:

:TSSE:SW 0,0,0,0 ---- set LCR scan to disable 4 curves

:TSSE:SW 0,1,0,1 ---- set LCR scanning to turn on only the 2nd and 4th curves

:TSSE:SW 2,1,2,1 ---- set LCR scanning to disable 1st and 3rd displays

:TSSE:SW4 0 ---- set LCR scanning to turn off the 4th display

TSSE:SW? ---- Queries the status of the 4-bar display switch for LCR scanning.

9.2.15 Handler subsystem commands

9.2.15.1 LCR handler subsystem commands

◆ Description: Set LCR Handler mode

Command syntax:

:HAND:STAT?

:HAND:STAT <0|1|2|OFF|ON|BUS>

Parameter:

0|OFF ---- means default

1|ON ---- means custom

2|BUS ---- means bus control

Example:

:HAND:STAT 0 ----Set the HANDLE mode as default;

:HAND:STAT OFF ----Set the HANDLE mode as default;

:HAND:STAT 1 ----Set the HANDLE mode to custom;
 :HAND:STAT ON ----Set the HANDLE mode to custom;
 :HAND:STAT BUS ---- Return to the HANDLE mode to BUS.

◆ Description: Set LCR Handler custom output control

Command syntax:

:HAND:STAT:OFfLO <...>
 :HAND:STAT:OFfHI <...>
 :HAND:STAT:LVLO <...>
 :HAND:STAT:LVHI <...>
 :HAND:STAT:PUHI <...>
 :HAND:STAT:PULO <...>

Parameter:

<...> is a list format, such as 1, 2, 4, 7, 14, 24, etc., corresponding to the table position displayed by the instrument

Example:

:HAND:STAT:OFLO 1,3,5,9 ----Set the 1,3,5,9 index function as constant low level;
 :HAND:STAT:OFHI 1,3,5,9 ----Set the index function of 1,3,5,9 to a constant high level;
 :HAND:STAT:LVLO 1,3,5,9 ----Set the index function of 1,3,5,9 to active low level;
 :HAND:STAT:LVHI 1,3,5,9 ----Set the index function of 1,3,5,9 to active high level;
 :HAND:STAT:PUHI 1,3,5,9 ----Set the index function of 1,3,5,9 to active high pulse;
 :HAND:STAT:PULO 1,3,5,9 ----Set the index function of 1,3,5,9 to active low pulse;

◆ Description: Set LCR Handler bus output control

Command syntax:

:HAND:OUTP:LVHI <...>
 :HAND:OUTP:LVLO <...>

Parameter:

<...> is a list format, such as 1, 2, 4, 7, 14, 24, etc., corresponding to the table position displayed by the instrument

Example:

:HAND:LVHI:LVHI 1,3,5,9 ----Set 1,3,5,9 to output high level in bus mode;
 :HAND:LVLO:LVLO 1,3,5,9 ----Set 1,3,5,9 to output low level in bus mode;

9.2.16 FETCh? subsystem commands

9.2.16.1 General query test results

◆ Description: Query the result of the last measurement in the current test mode

Command syntax:

:FETCh? ----Returns the test result of the parameter

Parameter:

Example:

Test page		
LCR	Component	Parameter 1 Result, Parameter 2 Result, Parameter 3 Result, Parameter 4

Meter	testing	<p>Result, the sorting results: such as: 1.12345E2, 1.23456E-2, 1.11023E2, -1.12345E2,1 The sorting results take the following values:</p> <table border="1"> <thead> <tr> <th>Sorting result</th> <th>Description</th> </tr> </thead> <tbody> <tr> <td>0</td> <td>BIN OUT</td> </tr> <tr> <td>1~10</td> <td>BIN 1~10</td> </tr> </tbody> </table> <p>Note: The <bin> data will only be displayed when the instrument compare function is turned ON.</p>	Sorting result	Description	0	BIN OUT	1~10	BIN 1~10		
	Sorting result	Description								
	0	BIN OUT								
1~10	BIN 1~10									
List sweep	<p>Return to the test result of the current test point. Click index, parameter 1 result, parameter 2 result, parameter 3 result, parameter 4 result, the compare results: such as: 2,1.12345E2,1.23456E-2,1.11023E2,-1.12345E2,1 The comparison results are as follows:</p> <table border="1"> <thead> <tr> <th>Compare results</th> <th>Description</th> </tr> </thead> <tbody> <tr> <td>0</td> <td>Not Compare</td> </tr> <tr> <td>1</td> <td>Pass</td> </tr> <tr> <td>Other</td> <td>Fail</td> </tr> </tbody> </table>	Compare results	Description	0	Not Compare	1	Pass	Other	Fail	
Compare results	Description									
0	Not Compare									
1	Pass									
Other	Fail									
Trace Sweep	<p>Returns the test result of the current test point, X-axis size, point index, parameter 1 result, parameter 2 result, parameter 3 result, parameter 4 result e.g: 1.00000E3,2,1.12345E2,1.23456E-2,1.11023E2,-1.12345E2 In the automatic return state, the scan results are reported together after the continuous scan is completed, and the results of "CtDt Ct,Dt,Kp,Qm,deltaF" are added at the end.</p>									
Transformer	Single Test	<p>Return to the test result of the current test point. Serial number index, parameter name, parameter result comparison result, such as: 2,lx,1.12345E2,1 The comparison results are as follows:</p> <table border="1"> <thead> <tr> <th>Compare results</th> <th>Description</th> </tr> </thead> <tbody> <tr> <td>0</td> <td>Not Compare</td> </tr> <tr> <td>1</td> <td>Pass</td> </tr> <tr> <td>Other</td> <td>Fail</td> </tr> </tbody> </table>	Compare results	Description	0	Not Compare	1	Pass	Other	Fail
	Compare results	Description								
0	Not Compare									
1	Pass									
Other	Fail									
Scan										

◆ Description: Query the test level monitoring results

Command syntax:

:FETCh:SMON:VAC? ----Return to the voltage monitoring result

:FETCh:SMON:IAC? ----Return to the current monitoring result

Parameter:

Example:

9.2.16.2 Automatic return of data

- ◆ Description: Automatically return test result setting (do not save state after power off)

Command syntax:

:FETCh:AUTO <? |0|OFF|1|ON|2>.

Parameters: ?

? ---- means query auto return status;

0|OFF---- means turn off auto return status;

1|ON---- means trigger the end of the test to automatically return to the test results of this time, the result format is the same as the above FETCH?

2---- means trigger the end of the test results to return to the end of the status, do not directly return the results;

return "Trig Eom\n " indicates the end of the test;

return "Trig Pause\n" indicates that the test is paused (transformer paging scanning application).

3---- for transformer scanning, automatically return the measured parameters of the ASCII data format.

Example:

:FETCh:AUTO? ---- Query automatically Return to setting status

:FETCh:AUTO 0 ---- Close trigger automatically Return to setting status

:FETCh:AUTO 1 ---- End trigger automatically Return to test data

:FETCh:AUTO 2 ---- Trigger end return to end state

9.2.16.3 Query List Scan Result

- ◆ Description: Query Curve Scan Result

Syntax:

:FETCh:LIST:PARA<1|2|3|4>? ---- Returns a list of all test points for the specified parameter.

:FETCh:LIST:PT<1~201>? ---- returns the test results of all points in the list of specified parameters

:FETCh:LIST:COMP[1~201]? ---- returns the result of the comparison at the specified point in the list.

:FETCh:LIST[1~201]? ---- returns the 4 parameters and the comparison results for all points in the list.

Parameters:

Examples:

:FETCh:LIST:PARA1? ---- returns the test results for list scan parameter 1

:FETCh:LIST:PARA2? ---- returns test results for list scan parameter 2

:FETCh:LIST:PARA3? ---- returns the test results for list scan parameter 3

:FETCh:LIST:PARA4? ---- returns test results for list scan parameter 4

:FETCh:LIST:PT5? ---- returns test results for all parameters at location 5

:FETCh:LIST:COMP? ---- returns comparison results for all points in the list

:FETCh:LIST:COMP4? ---- Returns the comparison result of the 4th item in the list

:FETCh:LIST? ---- Returns the result of the 4 parameters of all points in the list

e.g. P1.1,P1.2,P1.3,P1.4,P1.cmp,P2.1

:FETCh:LIST3? ---- Return to the list of the third point of the 4 parameters and the results of the comparison

Note: multiple data with the back comma ',' to do the separation, if there is a parameter display is turned off, then the separator in the middle of the content of the data is no data.

9.2.16.4 Query trace sweep results

◆ Description: Query trace sweep results

Command systax:

:FETCh:TRACE:X[1~801]? ----Returns the abscissa of the trace sweep

:FETCh:TRACE:Y<1|2|3|4>? ----Returns the test result of the specified curve (all points)

:FETCh:TRACE:PT<1~801>? ----Returns the result of the specified point (x,y1,y2,y3,y4)

:FETCh:TRACE:MARK?----Returns the results at the cursor of all traces (x, y1, y2, y3, y4)

:FETCh:TRACE:YMAX<1|2|3|4>? ----Returns the maximum value (x,y) of the specified curve

:FETCh:TRACE:YMIN<1|2|3|4>? ----Returns the minimum value (x,y) of the specified curve

Parameter:

Example:

:FETCh:TRACE:X? ----Return to a list of all the abscissa data of the trace sweep

:FETCh:TRACE:X5? ---- Return to the abscissa of the 5th point of the trace sweep

:FETCh:TRACE:Y1? ----Return to the test result of trace curve 1

:FETCh:TRACE:Y2? ----Return to the test result of trace curve 2

:FETCh:TRACE:Y3? ----Return to the test result of trace curve 3

:FETCh:TRACE:Y4? ----Return to the test result of trace curve 4

:FETCh:TRACE:PT5? ----Return to the result of all curves at point 5

:FETCh:TRACE:MARK? ----Returns the result at the curve cursor (x, y1, y2, y3, y4)

:FETCh:TRACE:YMAX1? ----Returns the maximum value of curve 1 (x,y)

:FETCh:TRACE:YMAX2? ----Returns the maximum value of curve 2 (x,y)

:FETCh:TRACE:YMAX3? ----Returns the maximum value of curve 3 (x,y)

:FETCh:TRACE:YMAX4? ----Returns the maximum value of curve 4 (x,y)

:FETCh:TRACE:YMIN1? ----Returns the minimum value of curve 1 (x,y)

:FETCh:TRACE:YMIN2? ----Returns the minimum value of curve 2 (x,y)

:FETCh:TRACE:YMIN3? ----Returns the minimum value (x,y) of curve 3

:FETCh:TRACE:YMIN4? ----Returns the minimum value of curve 4 (x,y)

9.2.16.5 Query transformer single group result

◆ Description: Query transformer single group test result

Command syntax:

:FETCh:TRT <0~12> ---- Returns the test result of the specified point.

:FETCh:TRTLine <1~12> ---- returns the test result from point 1 to the specified point.

Parameters: 0

0 ---- return test data from all points

1~12 ---- return test data of specified point

The format of single-point return data is: pt,paraStr,val,comp is: pt,paraStr,val,comp

The format of multi-point return data is single-point return data separated by ','.

Example:

:FETCh:TRT 0 ---- returns test data from all points

:FETCh:TRT 1 ---- returns test data from the 1st point

:FETCh:TRT 10 ---- returns test data from point 10

:FETCh:TRT 12 ---- returns test data from point 10

:FETCh:TRTL 5 ---- returns test data for points 1~5

:FETCh:TRTL 11 ---- returns test data for points 1~11

9.2.17 CORRection subsystem commands

The CORRection subsystem commands are mainly used to set the correction function, OPEN, SHORT, LOAD.

9.2.17.1 OPEN

◆ Description: Execute preset test point open circuit clearing

Command systax:

:CORR:OPEN [ACK]

Parameter:

Example:

:CORR:OPEN ---- Perform the open circuit clearing operation on the preset point, no return

:CORR:OPEN ACK ---- Perform the open circuit clearing operation on the preset point

Return to 1 for open circuit success and 0 for failure

◆ Description: Set the open circuit correction switch state

Command systax:

:CORR:OPEN:STAT?

:CORR:OPEN:STAT <0|1|ON|OFF>

Parameter:

0|OFF ---- OFF

1|ON ---- ON

Example:

:CORR:OPEN:STAT 0 ----Set the open circuit clearing state to ON

:CORR:OPEN:STAT 1 ----Set the open circuit clearing state to OFF

:CORR:OPEN:STAT? ----Return to open circuit clearing switch status

9.2.17.2 SHORT

◆ Description: Execute preset test point short circuit clearing

Command systax:

:CORR:SHOR [ACK]

Parameter:

Example:

:CORR:SHOR ---- Perform short-circuit clearing operation on preset point, no return

:CORR:SHOR ACK---- Perform short-circuit clearing operation on preset point,

Return to 1 for open circuit success and 0 for failure

◆ Description: Set the state of the short-circuit correction switch

Command syntax:

:CORR:SHOR:STAT?

:CORR:SHOR:STAT <0|1|ON|OFF>

Parameter:

0|OFF ---- OFF

1|ON ---- ON

Example:

:CORR:SHOR:STAT 0 ----Set the short-circuit clearing state to ON

:CORR:SHOR:STAT 1 ----Set the short-circuit clearing state to OFF

:CORR:SHOR:STAT? ---- Return to short circuit clearing switch status

9.2.17.3 LOAD

◆ Description: Set the load correction switch state

Command syntax:

:CORR:LOAD:STAT?

:CORR:LOAD:STAT <0|1|ON|OFF>

Parameter:

0|OFF ---- OFF

1|ON ---- ON

Example:

:CORR:LOAD:STAT 0 ----Set the load correction status to ON

:CORR:LOAD:STAT 1 ----Set the load correction status to OFF

:CORR:LOAD:STAT? ----Return to load correction switch status

9.2.17.4 Load type

◆ Description: It is used to set the measured combination parameter function for load correction

Command syntax:

:CORR:LOAD:TYPE?

:CORR:LOAD:TYPE <para>

Parameter:

para ---- Indicate the optional function parameter name, the value is as follows:

Parameter name	Parameter meaning
LSRS	LS-RS
LSQ	LS-Q
CPD	CP-D

Example:

:CORR:LOAD:TYPE LSRS ----Set the load type to LS-RS
:CORR:LOAD:TYPE LSQ ----Set the load type to LS-Q
:CORR:LOAD:TYPE CPD ----Set the load type to CP-D
:CORR:LOAD:TYPE? ---- Return to the load type

9.2.17.5 LENGth

◆ Description: Set the correction cable length of the instrument

Command systax:

:CORR:LENG?

:CORR:LENG <0|1>

Parameter:

0|1----0m, 1m

Example:

:CORR:LENG 0 ----Set the cable length to 0 meter

:CORR:LENG 1 ----Set the cable length to 1 meter

:CORR:LENG? ----Return to the cable length

9.2.17.6 CLear

◆ Description: Clear user correction data

Command systax:

:CORR:CLE [pt]

Parameter:

[pt] ---- means that the parameter can be omitted, the value range of pt is 1~10, indicating the specified correction point index

Example:

:CORR:CLE ----Clear all user correction data

:CORR:CLE 1 ----Clear the correction data of the first point calibrated by the user

:CORR:CLE 2 ----Clear the correction data of the second point calibrated by the user

:CORR:CLE 4 ----Clear the correction data of the 4th point calibrated by the user

:CORR:CLE 10 ----Clear the correction data of the 10th point calibrated by the user

9.2.17.7 DATA

◆ Description: Query the user correction data

Command systax:

:CORR[:USE]:DATA[n]?

Parameter:

n----The value is 1~10, which indicates the index of nth of dot frequency clearing point

Example:

:CORR:DATA? ----Returns the open circuit value, short circuit value, load correction value of all set points

<open1 A>,<open1 B>,<short1 A>,<short1 B>,<load1 A>,<load1 B>,<open2 A>,<open2 B>,<short2 A>,<short2 B>,<load2 A>,<load2 B>,...

:CORR:DATA1? ----Returns the correction data of the first point:

Point Index (1), Frequency, Open A, Open B, Short A, Short B, Load A, Load B, Reference A, Reference B

:CORR:DATA2? ----Returns the correction data of the second point:

Point Index (2), Frequency, Open A, Open B, Short A, Short B, Load A, Load B, Reference A, Reference B

:CORR:DATA3? ----Returns the correction data of the third point:

Point Index (3), Frequency, Open A, Open B, Short A, Short B, Load A, Load B, Reference A, Reference B

:CORR:DATA10? ----Returns the correction data of the tenth point:

Point Index (10), Frequency, Open A, Open B, Short A, Short B, Load A, Load B, Reference A, Reference B

◆ Description: Query the operation time of user correction

Command syntax:

:CORR:DATE <LAST|OPEN|SHORT|DCR|DCROPEN|DCRSHORT>

:CORR:DATE<n> <OPEN|SHORT|LOAD>

Parameter:

DATE<n> ----n indicates the nth frequency point

LAST ---- Indicates the time of the last clearing operation

OPEN/SHORT/LOAD ---- Represents open circuit correction/short circuit correction /load correction respectively

DCR/DCROPEN/DCRSHORT --- Indicates the last DCR/DCR open/DCR short correction respectively

Example:

:CORR:DATE LAST ---- Query the time of the last correction operation

:CORR:DATE OPEN ---- Query the time of full frequency open correction operation

:CORR:DATE SHORT ---- Query the time of the full-frequency short correction operation

:CORR:DATE DCR ---- Query the time of the last DCR correction operation

:CORR:DATE DCROPEN ---- Query the time of DCR open correction operation

:CORR:DATE DCRSHORT ---- Query the time of the DCR short correction operation

:CORR:DATE1 LAST ---- Query the time of the last point frequency 1 correction operation

:CORR:DATE2 OPEN ---- Query the time of point frequency 2 open correction operation

:CORR:DATE3 SHORT ---- Query the time of point frequency 3 short correction operation

:CORR:DATE10 LOAD ---- Query the time of point frequency 10 load correction operation

Note: The format of the returned data is "yyyy-MM-dd hh:mm:ss", and a return of "----" indicates that the date is invalid, that is, the correction operation has not been performed.

9.2.17.8 SPOT<n>

◆ Description: Set the switch state of the specified frequency point

Command syntax:

:CORR:SPOT<n>:STAT?

:CORR:SPOT<n>:STAT <0|1|ON|OFF>

Parameter:

n ---- subscript of frequency point index, value 1~10

0|OFF ---- OFF

1|ON ---- ON

Example:

:CORR:SPOT1:STAT 0 ----Set the frequency point 1 status to OFF

:CORR:SPOT3:STAT 1 ----Set the frequency point 3 state to OFF

:CORR:SPOT10:STAT? ----Return the status switch of frequency point 10

◆ Description: used to specify the measurement frequency of the frequency point

Command syntax:

:CORR:SPOT<n>:FREQ?

:CORR:SPOT<n>:FREQ <float | MIN | MAX>

Parameter:

float ---- Represent the floating-point data

Example:

:CORR:SPOT1:FREQ 1200 ----Set the frequency to 1200Hz;

:CORR:SPOT2:FREQ 1100HZ ----Set the frequency to 1100Hz;

:CORR:SPOT3:FREQ 1.2K ---- set the frequency to 1200Hz;

:CORR:SPOT4:FREQ? ---- Return to the frequency of frequency point 4

◆ Description: Perform open-circuit correction for instrument specific frequency points
(frequency 1, frequency 2...)

Command syntax:

:CORR:SPOT<n>:OPEN

Parameter:

Example:

:CORR:SPOT1:OPEN ---- Perform open circuit correction on frequency point 1

:CORR:SPOT2:OPEN ---- Perform open circuit correction on frequency point 2

:CORR:SPOT10:OPEN ---- Perform open circuit correction on frequency point 10

Returns 1 for open circuit success and 0 for failure

◆ Description: Perform short-circuit correction for instrument specific frequency points
(Frequency 1, Frequency 2...)

Command syntax:

:CORR:SPOT<n>:SHOR

Parameter:

Example:

:CORR:SPOT1:SHOR ---- Perform short-circuit correction on frequency point 1

:CORR:SPOT2:SHOR ---- Perform short-circuit correction on frequency point 2

:CORR:SPOT10:SHOR ---- Perform short-circuit correction on frequency point 10

Returns 1 for open circuit success and 0 for failure

◆ Description: Perform load correction reference values for specific frequency points of the instrument (Frequency 1, Frequency 2...)

Command syntax:

:CORR:SPOT<n>:LOAD:STAN?

:CORR:SPOT<n>:LOAD:STAN <refA,refB>

Parameter:

refA ---- the floating point data of reference A

refB ---- the floating point data of reference B

Example:

:CORR:SPOT1:LOAD:STAN 1.1,1.2 ---- The reference value for load correction at frequency point 1

:CORR:SPOT2:LOAD:STAN 1.1,1.2 ---- The reference value for load correction at frequency point 2

:CORR:SPOT10:LOAD:STAN? ----Return to the reference value for load correction of frequency point 10

◆ Description: Perform load correction on instrument specific frequency points (Frequency 1, Frequency 2...)

Command syntax:

:CORR:SPOT<n>:LOAD

Parameter:

Example:

:CORR:SPOT1:LOAD ---- Perform load correction of frequency point 1

:CORR:SPOT2:LOAD ---- Perform load correction of frequency point 2

:CORR:SPOT10:LOAD ----Return to perform load correction of frequency point 10

Return to 1 for open circuit success and 0 for failure

9.2.18 Mass MEMory subsystem commands

The Mass MEMory subsystem commands are used for file storing and load.

9.2.18.1 LOAD

◆ Description: Used to load saved files

Command syntax:

:MMEM:LOAD?

:MMEM:LOAD <file>

Parameter:

file ---- specify the path of the file to be loaded, relatively complete file path or the index number of the internal file fixed file, ranging from 1 to 50;

The corresponding relationship between the index number and the file is as follows:

Index number	1~50
LCR Mode	LCR.sda/LCR2.sda... in the root directory of internal files
Transformer	TRT.trt/TRT2.trt... in the root directory of

single group mode	internal files
Transformer scan mode	TRS.t40/TRS2.t40 in the root directory of the internal files

Example:

:MMEM:LOAD 1 ----Load the file whose path is LCR.sta
 :MMEM:LOAD 9 ----Load the file whose path is LCR9.sta
 :MMEM:LOAD sss.sta ---- Load the file whose path is files/sss.sta
 :MMEM:LOAD files/sss.sta ---- Load the file whose path is files/sss.sta
 :MMEM:LOAD usb/sss.sta ----Load the file whose path is usb/sss.sta
 :MMEM:LOAD? ---- Return to the pathname of the file to load

9.2.18.2 STORE

◆ Description: used to save the current instrument settings to a file

Command syntax:

:MMEM:STOR <n>[,file]

Parameter:

n ---- for use with the default saved file naming

file ---- specify the name of the file to save

The corresponding relationship between the index number and the default file is as follows:

Index number	1~50
LCR Mode	LCR.sda/LCR2.sda... in the root directory of internal files
Transformer single group mode	TRT.trt/TRT2.trt... in the root directory of internal files
Transformer scan mode	TH2840.t40/TH28402.t40...in the root directory of internal files

Example:

:MMEM:STOR 1 ----Save LCR.sta file (in LCR mode)
 :MMEM:STOR 9 ----Save LCR9.sta file (in LCR mode)
 :MMEM:STOR5,sss.sta ----Save the file with the path sss.sta
 :MMEM:STOR5,files/sss.sta ----Save the file whose path is files/sss.sta
 :MMEM:STOR5,usb/sss.sta ----Save the file whose path is usb/sss.sta

9.2.19 TRAN subsystem commands

The TRAN subsystem commands are mainly used to transformer parameters, such as turn-ratio, primary inductance, leakage inductance, stray capacitance, impedance, AC impedance, DC resistance, working mode and limits of each parameter.

9.2.19.1 Test mode

◆ Description: Set single group test mode

Command syntax:

:TRT:MODE?

:TRT:MODE<SEQ | STEP>

parameter:

SEQ ---- Continue

STEP ----Single STEP

Example:

:TRT:MODE SEQ ----Set to continue mode

:TRT:MODE STEP ----Set to single step mode

:TRT:MODE? ----Return to single group test mode

9.2.19.2 Compare

◆ Description: Set single group compare mode

Command syntax:

:TRT:COMP?

:TRT:COMP <OFF|0|ON|1>

Parameter:

OFF|0 ---- Turn off the compare function

ON|1 ----Turn on the compare function

Example:

:TRT:COMP OFF ---- Turn off the compare function

:TRT:COMP 0 ---- The same as above

:TRT:COMP ON ----Turn on the compare function

:TRT:COMP 1 ---- The same as above

:TRT:COMP? ----Return to single group compare function switch

9.2.19.3 Function

◆ Description: Set the "function" parameters of a single group of specified points

Command syntax:

:TRT:FUNC<n>?

:TRT:FUNC<n><para>

Parameter:

n ----Specify the index of the scan point, ranging from 1 to 12

para ---- Indicate the optional function parameter name, the value is as follows:

Parameter name	Parameter meaning	Parameter name	Parameter meaning
CP	Equivalent parallel	CS	Equivalent series

	capacitance		capacitance
LP	Equivalent parallel inductance	LS	Equivalent series inductance
RP	Equivalent parallel resistance	RS	Equivalent series resistance
D	Loss factor	Q	Quality factor
ZX	Absolute value of impedance	RD	DC Resistance
LK	Leakage inductance	DZ	Impedance degree
NS	Primary turn	NSNP	Primary turn /secondary turn
NP	Secondary turn	NPNS	Secondary turn /primary turn

Example:

:TRT:FUNC1 CP ----Set the parameter function of point 1

:TRT:FUNC5 NS ----Set the parameter function of point 5

:TRT:FUNC12NSNP ----Set the parameter function of point 12

:TRT:FUNC1? ----Return to the parameter function of point 1

9.2.19.4 Frequency

◆ Description: Set the sweep point frequency

Command syntax:

:TRT:FREQ<n>?

:TRT:FREQ<n><fn>

Parameter:

n ---- start from the nth point

fn ---- The floating-point number of sweep point n

Example:

:TRT:FREQ1 20 ----Set the frequency of the first point;

:TRT:FREQ6 1k ---- Set the frequency of the 6th point;

:TRT:FREQ12 20k ----Set the frequency of the 12th point;

:TRT:FREQ4? ----Return to the frequency of point 4;

9.2.19.5 Level

◆ Description: Set the test level of sweep point

Command syntax:

:TRT:LEV<n>?

:TRT:LEV<n><fn>

Parameter:

n ---- Specify the index of the sweep point, ranging from 1 to 12

fn ---- The floating-point number of sweep point n

Example:

:TRT:LEV1 0.5 ----Set the voltage of the first point;
:TRT:LEV2 1.1 ----Set the voltage of the second point;
:TRT:LEV6 2.5 ---- Set the voltage of the 6th point;
:TRT:LEV4? ----Return to the voltage of point 4;

9.2.19.6 Bias voltage

◆ Description: Set the bias voltage of the sweep point

Command syntax:

:TRT:BIAS:VOLT<n>?
:TRT:BIAS:VOLT<n><fn>

Parameter:

n ---- Specify the index of the sweep point, ranging from 1 to 12
fn ---- The floating-point number of sweep point n

Example:

:TRT:BIAS:VOLT1 1.2 ----Set the bias voltage of the first point;
:TRT:BIAS:VOLT6 1.5 ----Set the bias voltage of the sixth point;
:TRT:BIAS:VOLT4? ----Return to the bias voltage of point 4;

9.2.19.7 Bias current

◆ Description: Set the scan point bias current

Command syntax:

:TRT:BIAS:CURR<n>?
:TRT:BIAS:CURR<n><fn>

Parameter:

n ---- Specify the index of the sweep point, ranging from 1 to 12
fn ---- The floating-point number of sweep point n

Example:

:TRT:BIAS:CURR1 1m ----Set the bias current of the first point;
:TRT:BIAS:CURR6 5m ----Set the bias current of the sixth point;
:TRT:BIAS:CURR4? ----Return to the bias current of point 4

9.2.19.8 Turn ratio relative reference value

◆ Description: Set the relative reference value under the turn ratio function

Command syntax:

:TRT:TURN<n>?
:TRT:TURN<n><fn>

Parameter:

n ---- Specify the index of the sweep point, ranging from 1 to 12
fn ---- The floating-point number of sweep point n

Example:

:TRT:TURN1 1 ----Set the relative reference value of the first point under turn ratio function to 1 turn;

:TRT:TURN610 ----Set the relative reference value of the 6th point under turn ratio function to 10 turns;

:TRT:TURN4? ----Return to the relative reference value of the 4th point under turn ratio function.

9.2.19.9 Deviation and nominal value

◆ Description: Set the deviation comparison mode of the instrument

Command syntax:

:TRT:DEV<n>?

:TRT:DEV<n><ABS|PER|OFF>

Parameter:

ABS---- Δ Absolute deviation

PER ---- $\Delta\%$ percent deviation

OFF ---- OFF

Example:

:TRT:DEV1 ABS ----Set the comparison mode of point 1 to absolute deviation

:TRT:DEV2 PER ----Set the comparison mode of point 2 to percent deviation

:TRT:DEV3 OFF ----Turn off the deviation mode of comparison mode of point 3

:TRT:DEV2? ----Return to the deviation mode of comparison mode of point 2

◆ Description: Set the nominal value of the deviation of the instrument

Command syntax:

:TRT:NOM<n>?

:TRT:NOM<n><float>

Parameter:

float ---- Represent the floating-point number

Example:

:TRT:NOM110.2 ----Set the comparison nominal value of point 1

:TRT:NOM2 2.3 ----Set the comparison nominal value of point 2

:TRT:NOM3 62.5 ---- Turn off the comparison nominal value of point 3

:TRT:NOM2? ----Return to the comparison nominal value of point 2.

9.2.19.10 High and low limits

◆ Description: Set the instrument's lower limit for comparison

Command syntax:

:TRT:LOW<n>?

:TRT:LOW<n><float>

Parameter:

float ---- Represent the floating-point number

Example:

:TRT:LOW110.2 ----Set the comparison lower limit of point 1

:TRT:LOW2 2.3 ----Set the comparison lower limit of point 2
:TRT:LOW3 62.5 ----Turn off the comparison lower limit of point 3
:TRT:LOW2? ----Return to the comparison lower limit of point 2
◆ Description: Set the high limit of the comparison of the instrument
Command syntax:
:TRT:HIGH<n>?
:TRT:HIGH<n><float>
Parameter:
float ---- Represent the floating-point number
Example:
:TRT:HIGH110.2 ----Set the comparison high limit of point 1
:TRT:HIGH2 2.3 ----Set the comparison high limit of point 2
:TRT:HIGH3 62.5 ---- Turn off the comparison high limit of point 3
:TRT:HIGH2? ---- Return to the comparison high limit of point 2

9.2.19.11 Average

◆ Description: Set the average number of sweep points
Command syntax:
:TRT:AVG[n]?
:TRT:AVG[n] <int>
Parameter:
n ---- Specify the index of the sweep point, ranging from 1 to 12
int ---- the average number of sweep points n, ranging from 1 to 255
Example:
:TRT:AVG1 1 ----Set the average times of point 1;
:TRT:AVG2 5 ----Set the average times of point 2;
:TRT:AVG6 20 ----Set the average times of point 6;
:TRT:AVG4? ---- Return to the average times of point 4.

9.2.19.12 Delay

◆ Description: Set the sweep point test delay
Command syntax:
:TRT:DEL[n]?
:TRT:DEL[n] <fn>
Parameter:
n ---- Specify the index of the sweep point, ranging from 1 to 12
fn ---- the floating-point number of sweep point
Example:
:TRT:DEL1 0.01 ----Set the test delay of point 1;
:TRT:DEL2 3m ---- Set the test delay of point 2;
:TRT:DEL6 5m ----Set the test delay of point 3;
:TRT:DEL4? ----Return to the test delay of point 4;

9.2.19.13 Switch

◆ Description: Set the sweep point switch state

Command syntax:

:TRT:STAT[n]?

:TRT:STAT[n] <OFF|0|ON|1>

Parameter:

n ---- Specify the index of the sweep point, ranging from 1 to 12

OFF|0 ---- Turn off the test function of the point

ON|1 ---- Turn on the test function of the point

Example:

:TRT:STAT1 OFF ----Turn off the test function of point 1

:TRT:STAT2 0 ----Turn on the test function of point 2

:TRT:STAT3 ON ----Turn on the test function of point 3

:TRT:STAT8 1 ----Turn on the test function of point 8

:TRT:STAT12? ----Return to the test function switch of point 12.

9.2.20 TRS Transformer Scan Command Set

9.2.20.1 Test Data Request

◆ Description: Full Parameter Return Switch in Auto Return State

Syntax:

:TRS:DATAALLSW <0|1|OFF|ON> //Full Parameter Return Switch in Auto Return State

:TRS:DATAALLSW? //Inquire about full parameter all switch in auto return state

Note: After switching off, only the parameter involved in the measurement will have the return value.

When turned on, all test data will be returned in the default format. All test data, the format is fixed, the specific format will be added to the manual later;

Parameter: 0/OFF ---- Close full parameter return switch

1/ON ---- Open the full parameter return switch, the default value

Example:

:TRS:DATAALLSW 0 ---- Close full parameter reset switch

:TRS:DATAALLSW 1 ---- Open full parameter reset switch

:TRS:DATAALLSW OFF ---- Close full parameter reset switch

:TRS:DATAALLSW ON ---- Enable full parameter reset switch

:TRS:DATAALLSW? ---- Querying the Full Parameter Allow Switch

◆ Description: Queries test data in transformer scan mode

Command syntax:

:TRS:DATA? //Returns all test results in hex format. The format length is relatively fixed

:TRS:DATA:<para>? //Hexadecimal format returns the specified test result.

:TRS:AsciiDATA:<para>? //Ascii format returns the specified test result.

Parameters:

para ---- The value of ---- specifies the name of the parameter to be queried, and the specific values are as follows:

Parameter Index	Para Value	Value Meaning
0	TURN	Circle Ratio Result
1	LX	Inductance
2	Q	Quality Factor
3	LK	Leakage
4	CX	Capacitance
5	CXD	Losses
6	ZX	Impedance
7	ACR	AC Resistance
8	DCR	DC Resistance
9	PS	Short Circuit Test
10	BL	Balance Test
11	PH	Phase

Example:

:TRS:DATA:TURN? ---- Query circle ratio data and compare result

:TRS:DATA:LX? ---- Query inductance data and compare result

:TRS:DATA:LK? ---- Query leakage inductance data and compare result

:TRS:DATA:Q? ---- Query quality factor data and compare result

:TRS:DATA:CX? ? ---- Query capacitance data and comparison result

:TRS:DATA:PH? ---- Query phase comparison result under circle ratio test, no test data

:TRS:DATA:ACR? ---- Query AC resistance ACR data and comparison result

Note: The data byte return format is described as follows: TURN for example.

1Byte	1Byte	8Byte	4Byte*60*10	1Byte*60*10	1Byte	1 or 2Byte
#	PriSets	reserve	Test Results	Comparison Results	Total Comparison Results	\n or \r\n

:TRS:DATA? //Returns all test results in hexadecimal format, with a relatively fixed length.

1Byte	1Byte	8Byte	4Byte*60*10 *11(parameter)	1Byte*60*10 *11(parameter)	1Byte	1 or 2Byte
#	PriSets	reserve	Test results Parameters in order 0~10	Comparison results Parameters in order 0~10	Total comparison results	\n or \r\n

:TRS:ADATA:TURN? //Ascii format returns the specified test result

Note: The return data format is as follows: take TURN for example

#seg1,<pri,sec,paraIdx,comp,val;>*PriSet*SecSet\n

where seg1 is the total result of the comparison, '0' (not compared), '1' (qualified), '2|3|4' (unqualified).

pri---- is the primary index corresponding to the data

sec---- specifies the secondary index corresponding to the data

paraIdx---- is the parameter function index.

comp---- is the comparison result

val---- indicates the test result

As above, 5 for a group, is for a winding group of results, the number of cycles PriSet*SecSet

9.2.20.2 Transformer Operation Status Query

◆ Description: Transformer Operation Status Query

Command syntax:

:TRS:STAT?

Parameter:

Example:

:TRS:STAT? ---- Transformer operation status query, return content is as follows:

Return Content	Meaning
IDEL	Idle: indicates the state of not triggered or triggered to the first point before the test.
RUN	Test in progress: indicates the state from the start of the test to the end of the test
DATA	Data is equipped, ie the end of the test
PAUSE	Test paused, such as the specified page after the test to pause state

Note: Suggested application scenario: In the non-automatic data return state, the host reads the data based on the queried state and then takes the initiative to read the data.

9.2.20.3 Transformer File Sending

◆ Description: The host sends the transformer test file

Command syntax:

:TRS:FILL <file byte length>

Parameters:

File byte length: i.e., the number of bytes contained in the contents of the transformer file.

Example:

:TRS:FILL 14336 ---- is about to send the data content of 14336 bytes in length.

Note: 14336 is only a description of the use of the specific value is determined by the length of the data content to be sent. Note: 14336 is only a description, the specific value is determined by the length of the data to be sent, and then you need to send the specified length of the data content to the instrument in order bytes, please strictly adhere to the format of the file editing to generate a valid configuration file, otherwise it is easy to make mistakes.

9.2.20.4 Transformer Stop Scan

◆ Description: Stop Transformer Scan Control

Command syntax:

:TRS:STOP

Parameters:

The transformer scan action is stopped early in the scan process, which is equivalent to the Reset button on the panel.

Example:

:TRS:STOP ---- to stop the transformer scan action.

Note: Triggering again after stopping will restart the scan from the first parameter on the first page.

9.2.21 SYSTem system subsystem commands

The SYSTem subsystem command set is mainly used to set system-related parameter functions.

9.2.21.1 Bus Mode

◆ Description: Set the command mode of the communication interface

Command syntax:

:SYST:BUSMODE?

:SYST:BUSMODE <RS232|LAN|USBTMC|USBCDC|AUTO>

Parameter:

AUTO ----Automatically select the communication interface

Others ---- lock the communication interface to the command communication interface

Example:

:SYST:BUSMODE? ----Query the current communication interface mode

:SYST:BUSMODE RS232 ----Set the bus communication as a fixed RS232 interface

:SYST:BUSMODE LAN ----Set the bus communication as a fixed LAN interface

:SYST:BUSMODE USBTMC ----Set the bus communication as the fixed USBTMC interface

:SYST:BUSMODE USBCDC ----Set the bus communication as the fixed USBCDC interface

:SYST:BUSMODE AUTO ----Set the bus communication to the automatic interface mode

9.2.21.2 Key Sound

◆ Description: Set the key sound mode

Command syntax:

:SYST:BEEP?

:SYST:BEEP <OFF|ON|0|1>

Parameter:

0|OFF ---- OFF

1|ON ---- ON

Example:

:SYST:BEEP? ----Query the current key sound setup

:SYST:BEEP 0 ----Set the key sound to off

:SYST:BEEP OFF ----Set the key sound to off

:SYST:BEEP 1 ----Set the key sound to on

:SYST:BEEP ON ----Set the key sound to on

◆ Description: Set the beeper mode for PASS sorting

Command systax:

:SYST:BEEP:PASS?

:SYST:BEEP:PASS <OFF|TwoShort|LowLong|HighShort|HighLong>

Parameter:

OFF ---- off

Others correspond respectively: two short, low long, high short, high long

Example:

:SYST:BEEP:PASS? ----Query the current PASS beeper setting

:SYST:BEEP:PASS OFF ----Set the PASS beeper mode to OFF

:SYST:BEEP:PASS TS ----Set the PASS beeper mode to two short

:SYST:BEEP:PASS LL ----Set the PASS beeper mode to low long

:SYST:BEEP:PASS HS ----Set the PASS beeper mode to high short

:SYST:BEEP:PASS HL ----Set the PASS beeper mode to high long

◆ Description: Set the beeper mode for FAIL sorting

Command systax:

:SYST:BEEP:FAIL?

:SYST:BEEP:FAIL <OFF|TwoShort|LowLong|HighShort|HighLong>

Parameter:

OFF ---- off

Others correspond respectively: two short, low long, high short, high long

Example:

:SYST:BEEP:FAIL? ----Query the current FAIL beeper setting

:SYST:BEEP:FAIL OFF ----Set the FAIL beeper mode to OFF

:SYST:BEEP:FAIL TS ----Set the FAIL beep mode to two short

:SYST:BEEP:FAIL LL ----Set the FAIL beeper mode to low and long

:SYST:BEEP:FAIL HS ----Set the FAIL beep mode to high and short

:SYST:BEEP:FAIL HL ----Set the unqualified beeper mode to high and long

9.2.21.3 DateTime

◆ Description: Set the system time and date

Command systax:

:SYST:DATETIME?

:SYST:DATETIME <year, month, day, hour, minute, second>

Parameter:

Year----value range 2018~2999

Example:

:SYST:DATETIME? ----Query the current system time and date

:SYST:DATETIME 2021,11,08,12,35,56 ---- set 2021-11-08 12:35:56

9.2.21.4 RS232 Configuration

- ◆ Description: Set the baud rate

Command syntax:

:SYST:RS232:BAUD?

:SYST:RS232:BAUD <4800|9600|19200|38400|57600|115200>

Parameter:

Example:

:SYST:RS232:BAUD? ----Query RS232 baud rate

:SYST:RS232:BAUD 4800 ----Set the RS232 baud rate to 4800

:SYST:RS232:BAUD 9600 ----Set the RS232 baud rate to 9600

:SYST:RS232:BAUD 19200 ----Set the RS232 baud rate to 19200

:SYST:RS232:BAUD 38400 ----Set the RS232 baud rate to 38400

:SYST:RS232:BAUD 115200 ----Set the RS232 baud rate to 115200

- ◆ Description: Set the instrument bus address

Command syntax:

:SYST:RS232:ADDR?

:SYST:RS232:ADDR <1~32>

Parameter:

Example:

:SYST:RS232:ADDR? ----Query the bus address of the instrument

:SYST:RS232:ADDR 1 ----Set the instrument bus address to 1

:SYST:RS232:ADDR 2 ----Set the instrument bus address to 2

:SYST:RS232:ADDR 32 ----Set the instrument bus address to 32

- ◆ Description: Set the instrument communication command mode

Command syntax:

:SYST:RS232:CMDMODE?

:SYST:RS232:CMDMODE <SCPI|MODBUS>

Parameter:

Example:

:SYST:RS232:CMDMODE? ----Query the command mode of the instrument

:SYST:RS232:CMDMODE SCPI ----Set the instrument command mode to SCPI

:SYST:RS232:CMDMODE MODBUS ----Set the command mode to MODBUS

9.2.21.5 LAN Configuration

- ◆ Description: Set the LAN port number

Command syntax:

:SYST:LAN:PORT?

:SYST:LAN:PORT<int>

Parameter:

int---value range, consult the network management, recommended 1~65536, the factory default value is 45454

Example:

:SYST:LAN:PORT? ----Query the port number of the LAN port

:SYST:LAN:PORT 45454 ----Set the LAN port number

◆ Description: Set LAN port dhcp

Command systax:

:SYST:LAN:UDhcPc

Parameter:

Example:

:SYST:LAN:UDP? ----Set the instrument to automatically obtain the network configuration once

◆ Description: Set the IP address of the LAN port

Command systax:

:SYST:LAN:IPADdress?

:SYST:LAN:IPADdress <192.168.22.209>

Parameter:

Example: :SYST:LAN:IPAD? ----Query the IP address of the LAN port

:SYST:LAN:IPAD 192.168.22.209 ----Set the IP address of the LAN port

◆ Description: Set the LAN port gateway address

Command systax:

:SYST:LAN:GATeway?

:SYST:LAN:GATeway <192.168.22.1>

Parameter:

Example:

:SYST:LAN:GAT? ----Query LAN port gateway address

:SYST:LAN:GAT 192.168.22.1 ----Set the LAN port gateway address

◆ Description: Set the LAN port gateway address

Command systax:

:SYST:LAN:GATeway?

:SYST:LAN:GATeway <192.168.22.1>

Parameter:

Example:

:SYST:LAN:GAT? ----Query LAN port gateway address

:SYST:LAN:GAT 192.168.22.1 ----Set the LAN port gateway address

◆ Description: Set the subnet mask address of the LAN port

Command systax:

:SYST:LAN:SMASK?

:SYST:LAN:SMASK <255.255.255.0>

Parameter:

Example:

:SYST:LAN:SMASK? ----Query the subnet mask address of the LAN port

:SYST:LAN:SMASK 255.255.255.0 ----Set the subnet mask address of the LAN port

◆ Description: Set the DNS address of the LAN port

Command systax:

:SYST:LAN:DNS?

:SYST:LAN:DNS <255.23.12.0>,<255.23.14.1>

Parameter:

The DNS addresses at both ends represent the primary DNS address and the backup DNS address, respectively.

Example:

:SYST:LAN:DNS? ----Query the DNS address of the LAN port

:SYST:LAN:DNS 255.23.12.0,255.23.14.1 ----Set DNS address of LAN port

◆ Description: Query the MAC address of the LAN port

Command syntax:

:SYST:LAN:MAC?

Parameter:

Example:

:SYST:LAN:MAC? ----Query the MAC address of the LAN port

9.2.21.6 Update Command

◆ Description: use the command to control the instrument to perform the upgrade operation

Command syntax:

:SYST:UPDATE APP

Parameter:

Example:

:SYST:UPDATE APP ----use the command to control the instrument to call the default file in the USB flash drive to upgrade

Note: In addition, we have the software for the host computer to control the upgrade of the instrument, which can directly send the upgrade file from the host computer and perform the upgrade operation without the need for a USB flash drive (convenient for customers to make the second choice for upgrade), and the issued upgrade file is stored by default. In the internal storage of the instrument, such as update2840.sec, considering that the later upgrade file may be relatively large, the user can delete this file periodically.

9.3 Modbus commands

9.3.1 Command format

The command format is the internal version 2.0 standard, please refer to the following description for details:

9.3.1.1 Write Command

➤ **Sending format**

Instrument address	Function code	High address	Low address	High registers	Low registers	Total number of bytes	Data byte 1	...	Data byte n	CRC Low	CRC High
--------------------	---------------	--------------	-------------	----------------	---------------	-----------------------	-------------	-----	-------------	---------	----------

➤ **Return format**

Instrument address	Function code	High address	Low address	High registers	Low registers	CRC Low	CRC High
--------------------	---------------	--------------	-------------	----------------	---------------	---------	----------

◆ **Instrument address**

It refers to the local address of the instrument, which can be set in the bus address of the instrument's system setting interface. The value range is: 1~31

◆ **Function code: 0x10**

This command can write one data or multiple data, so its code is: 0x10

◆ **High address and low address**

It refers to the storage address of the data in the instrument, which can be a real storage address or a mapped address.

◆ **High registers and low registers**

It indicates that the number of registers written in this operation and the size of each register is 2 bytes.

◆ **Total number of bytes**

It represents the total number of bytes written in this operation.

◆ **Data byte 1~data byte n**

Write these data content to the instrument.

◆ **CRC high and CRC low**

CRC 16-bit check, we use the look-up table method for CRC check.

➤ **Example: The specific instruction and function setting relationship is detailed in the Appendix Table ModeBus command function comparison table (Section 9.3.3);**

Set the voltage range, set to Range 2 (ie 300V), the storage address of voltage range parameter in the instrument is 0x0003, the instrument bus address is 8.

Then the command is:

0x08	0x10	0x00	0x03	0x00	0x01	0x01	0x02	C5	FD
------	------	------	------	------	------	------	------	----	----

Where, the countdown 3rd is corresponding to 20% index value of voltage, the type is char and accounting for 1 byte.

The return information is as follows:

0x08	0x10	0x00	0x03	0x00	0x01	0XF1	0x50
------	------	------	------	------	------	------	------

9.3.1.2 Reading the command

➤ **Sending format**

Instrument address	Function code	High address	Low address	High registers	Low registers	CRC Low	CRC High
--------------------	---------------	--------------	-------------	----------------	---------------	---------	----------

➤ **Return format**

```

// CRC low byte value table
const BYTE chCRCLTalbe[] =
{
0x00, 0xC0, 0xC1, 0x01, 0xC3, 0x03, 0x02, 0xC2, 0xC6, 0x06, 0x07, 0xC7,
0x05, 0xC5, 0xC4, 0x04, 0xCC, 0x0C, 0x0D, 0xCD, 0x0F, 0xCF, 0xCE, 0x0E,
0x0A, 0xCA, 0xCB, 0x0B, 0xC9, 0x09, 0x08, 0xC8, 0xD8, 0x18, 0x19, 0xD9,
0x1B, 0xDB, 0xDA, 0x1A, 0x1E, 0xDE, 0xDF, 0x1F, 0xDD, 0x1D, 0x1C, 0xDC,
0x14, 0xD4, 0xD5, 0x15, 0xD7, 0x17, 0x16, 0xD6, 0xD2, 0x12, 0x13, 0xD3,
0x11, 0xD1, 0xD0, 0x10, 0xF0, 0x30, 0x31, 0xF1, 0x33, 0xF3, 0xF2, 0x32,
0x36, 0xF6, 0xF7, 0x37, 0xF5, 0x35, 0x34, 0xF4, 0x3C, 0xFC, 0xFD, 0x3D,
0xFF, 0x3F, 0x3E, 0xFE, 0xFA, 0x3A, 0x3B, 0xFB, 0x39, 0xF9, 0xF8, 0x38,
0x28, 0xE8, 0xE9, 0x29, 0xEB, 0x2B, 0x2A, 0xEA, 0xEE, 0x2E, 0x2F, 0xEF,
0x2D, 0xED, 0xEC, 0x2C, 0xE4, 0x24, 0x25, 0xE5, 0x27, 0xE7, 0xE6, 0x26,
0x22, 0xE2, 0xE3, 0x23, 0xE1, 0x21, 0x20, 0xE0, 0xA0, 0x60, 0x61, 0xA1,
0x63, 0xA3, 0xA2, 0x62, 0x66, 0xA6, 0xA7, 0x67, 0xA5, 0x65, 0x64, 0xA4,
0x6C, 0xAC, 0xAD, 0x6D, 0xAF, 0x6F, 0x6E, 0xAE, 0xAA, 0x6A, 0x6B, 0xAB,
0x69, 0xA9, 0xA8, 0x68, 0x78, 0xB8, 0xB9, 0x79, 0xBB, 0x7B, 0x7A, 0xBA,
0xBE, 0x7E, 0x7F, 0xBF, 0x7D, 0xBD, 0xBC, 0x7C, 0xB4, 0x74, 0x75, 0xB5,
0x77, 0xB7, 0xB6, 0x76, 0x72, 0xB2, 0xB3, 0x73, 0xB1, 0x71, 0x70, 0xB0,
0x50, 0x90, 0x91, 0x51, 0x93, 0x53, 0x52, 0x92, 0x96, 0x56, 0x57, 0x97,
0x55, 0x95, 0x94, 0x54, 0x9C, 0x5C, 0x5D, 0x9D, 0x5F, 0x9F, 0x9E, 0x5E,
0x5A, 0x9A, 0x9B, 0x5B, 0x99, 0x59, 0x58, 0x98, 0x88, 0x48, 0x49, 0x89,
0x4B, 0x8B, 0x8A, 0x4A, 0x4E, 0x8E, 0x8F, 0x4F, 0x8D, 0x4D, 0x4C, 0x8C,
0x44, 0x84, 0x85, 0x45, 0x87, 0x47, 0x46, 0x86, 0x82, 0x42, 0x43, 0x83,
0x41, 0x81, 0x80, 0x40
};

```

b) then calculate

```

WORD CRC16(BYTE* pchMsg, WORD wDataLen)
{
    BYTE chCRCHi = 0xFF; // High CRC byte initialization
    BYTE chCRCLo = 0xFF; // Low CRC byte initialization
    WORD wIndex;        // Index in the CRC loop
while (wDataLen--)
    {
        // Calculate CRC
        wIndex = chCRCLo ^ *pchMsg++;
        chCRCLo = chCRCHi ^ chCRCHTalbe[wIndex];
        chCRCHi = chCRCLTalbe[wIndex];
    }
    return ((chCRCHi << 8) | chCRCLo);
}

```

9.3.3 Command function comparison table

9.3.3.1 General Measurement Correlation

Instrument bus address	Function code	Command address	Number of data bytes Number of registers	Data Number	Data byte	Instruction function meaning																																				
Instrument address	Read/write	High + low	High + low	Data Number	The setting value corresponding to the address																																					
1~31	R	0x0000				Query the instrument IDN																																				
	R/W	0x0001	0x0001~0x0004	1~4	0x01~0x	Function, the parameter values are as follows: <table border="1" style="margin-left: 20px;"> <tr><td>0</td><td>CP</td><td>6</td><td>X</td><td>12</td><td>Q</td></tr> <tr><td>1</td><td>CS</td><td>7</td><td>G</td><td>13</td><td>dZ</td></tr> <tr><td>2</td><td>LP</td><td>8</td><td>B</td><td>14</td><td>rZ</td></tr> <tr><td>3</td><td>LS</td><td>9</td><td>Z</td><td>15</td><td>dY</td></tr> <tr><td>4</td><td>RP</td><td>10</td><td>Y</td><td>16</td><td>rY</td></tr> <tr><td>5</td><td>RS</td><td>11</td><td>D</td><td>17</td><td>RD</td></tr> </table>	0	CP	6	X	12	Q	1	CS	7	G	13	dZ	2	LP	8	B	14	rZ	3	LS	9	Z	15	dY	4	RP	10	Y	16	rY	5	RS	11	D	17	RD
0	CP	6	X	12	Q																																					
1	CS	7	G	13	dZ																																					
2	LP	8	B	14	rZ																																					
3	LS	9	Z	15	dY																																					
4	RP	10	Y	16	rY																																					
5	RS	11	D	17	RD																																					
	R/W	0x0002	0x0004	4	float	Frequency																																				
	R/W	0x0003	0x0001	1	0~3	Speed <table border="1" style="margin-left: 20px;"> <tr><td>0</td><td>FAST</td></tr> <tr><td>1</td><td>MED</td></tr> <tr><td>2</td><td>SLOW</td></tr> <tr><td>3</td><td>SFAST</td></tr> </table>	0	FAST	1	MED	2	SLOW	3	SFAST																												
0	FAST																																									
1	MED																																									
2	SLOW																																									
3	SFAST																																									
	R/W	0x0004	0x0001	1	0~1	Trigger <table border="1" style="margin-left: 20px;"> <tr><td>0</td><td>CONT</td></tr> <tr><td>1</td><td>SINGLE</td></tr> </table>	0	CONT	1	SINGLE																																
0	CONT																																									
1	SINGLE																																									
	R/W	0x0005	0x0001	1	0~1	Constant level <table border="1" style="margin-left: 20px;"> <tr><td>0</td><td>OFF</td></tr> <tr><td>1</td><td>ON</td></tr> </table>	0	OFF	1	ON																																
0	OFF																																									
1	ON																																									
	R/W	0x0006	0x0004	4	float	Trigger delay: 0~60.000s																																				
	R/W	0x0007	0x0004	4	float	Step delay: 0~60.000s																																				
	R/W	0x0008	0x0001	1	0~1	Voltage monitoring <table border="1" style="margin-left: 20px;"> <tr><td>0</td><td>OFF</td></tr> <tr><td>1</td><td>ON</td></tr> </table>	0	OFF	1	ON																																
0	OFF																																									
1	ON																																									
	R/W	0x0009	0x0001	1	0~1	Current monitoring <table border="1" style="margin-left: 20px;"> <tr><td>0</td><td>OFF</td></tr> <tr><td>1</td><td>ON</td></tr> </table>	0	OFF	1	ON																																
0	OFF																																									
1	ON																																									

	R/W	0x000A	0x0005	5	float+char	AC Level float+0/1(v/i)																														
	R/W	0x000B	0x0001	1	0~14	AC range <table border="1"> <tr> <td>0</td> <td>100k</td> <td>5</td> <td>2k</td> <td>10</td> <td>50</td> </tr> <tr> <td>1</td> <td>50k</td> <td>6</td> <td>1k</td> <td>11</td> <td>20</td> </tr> <tr> <td>2</td> <td>20k</td> <td>7</td> <td>500</td> <td>12</td> <td>10</td> </tr> <tr> <td>3</td> <td>10k</td> <td>8</td> <td>200</td> <td>13</td> <td>0.1</td> </tr> <tr> <td>4</td> <td>5k</td> <td>9</td> <td>100</td> <td></td> <td></td> </tr> </table>	0	100k	5	2k	10	50	1	50k	6	1k	11	20	2	20k	7	500	12	10	3	10k	8	200	13	0.1	4	5k	9	100		
0	100k	5	2k	10	50																															
1	50k	6	1k	11	20																															
2	20k	7	500	12	10																															
3	10k	8	200	13	0.1																															
4	5k	9	100																																	
	R/W	0x000C	0x0005	5	float+char	DC Bias float+0/1(v/i)																														
		0x000D				xx																														
	R/W	0x000E	0x0001	1	1~256	Average																														
	R/W	0x000F	0x0001	1	0~1	BIAS polarity <table border="1"> <tr> <td>0</td> <td>OFF</td> </tr> <tr> <td>1</td> <td>ON</td> </tr> </table>	0	OFF	1	ON																										
0	OFF																																			
1	ON																																			
	R/W	0x0010	0x0001	1	0~14	DC Range																														
	R/W	0x0011	0x0004	4	float	DC Level																														
		0x0012				xx																														
	R/W	0x0013	0x0001	1	0~1	DCI isolation <table border="1"> <tr> <td>0</td> <td>OFF</td> </tr> <tr> <td>1</td> <td>ON</td> </tr> </table>	0	OFF	1	ON																										
0	OFF																																			
1	ON																																			
	R/W	0x0014	0x0001	1	0~2	Deviation 1 <table border="1"> <tr> <td>0</td> <td>OFF</td> </tr> <tr> <td>1</td> <td>ABS</td> </tr> <tr> <td>2</td> <td>PER</td> </tr> </table>	0	OFF	1	ABS	2	PER																								
0	OFF																																			
1	ABS																																			
2	PER																																			
	R/W	0x0015	0x0001	1	0~2	Deviation 2 <table border="1"> <tr> <td>0</td> <td>OFF</td> </tr> <tr> <td>1</td> <td>ABS</td> </tr> <tr> <td>2</td> <td>PER</td> </tr> </table>	0	OFF	1	ABS	2	PER																								
0	OFF																																			
1	ABS																																			
2	PER																																			
	R/W	0x0016	0x0004	4	float	Reference 1																														
	R/W	0x0017	0x0004	4	float	Reference 2																														
	R/W	0x1000	0x0001	1	0~2	Deviation 3 <table border="1"> <tr> <td>0</td> <td>OFF</td> </tr> <tr> <td>1</td> <td>ABS</td> </tr> <tr> <td>2</td> <td>PER</td> </tr> </table>	0	OFF	1	ABS	2	PER																								
0	OFF																																			
1	ABS																																			
2	PER																																			
	R/W	0x1001	0x0001	1	0~2	Deviation 4 <table border="1"> <tr> <td>0</td> <td>OFF</td> </tr> <tr> <td>1</td> <td>ABS</td> </tr> <tr> <td>2</td> <td>PER</td> </tr> </table>	0	OFF	1	ABS	2	PER																								
0	OFF																																			
1	ABS																																			
2	PER																																			
	R/W	0x1002	0x0004	4	float	Reference 3																														
	R/W	0x1003	0x0004	4	float	Reference 4																														
	R/W	0x0019	4*n	4*n	float*n	Reference value, set 1~4 reference values The value of n is 1~4, that is, you can set 1, 2, 3 or 4 reference values at the same time																														

Multi-Parameter Batch Setup						
R/W	0x1020	0x0004	4	float		

◆ Multi-parameter batch read/write (relative to the first measured parameter above)

Function Code	Instruction Address	Number of data bytes Number of registers	Number of data	Data content	Command Function Description				
Read/Write	High + Low	High + Low	Number of data	Address corresponds to setting value					
R/W	0x1020	n	2n	...	Batch read/write of measurement related parameter settings				
The parameters of the n registers (1~n) are as follows:									
1	2	3	4	5	6	7	8	9	10
Function 1	Function 2	Function 3	Function 4	Function 1 switch	Function 2 switch	Function 3 switch	Function 4 switch	Frequency	
11	12	13	14	15	16	17	18	19	20
AC Level Type	AC Voltage		AC Current		DC Level		Speed	Range auto switch	AC Range
21	22	23	24	25	26	27	28	29	30
DC Range	Trigger Mode	Trigger Delay		Step Delay		Average Count	Bias Source	Bias Output State	Bias Polarity
31	32	33	34	35	36	37	38	39	
DC Bias Type	DC Bias Voltage		DC Bias Current		Mode 1 Deviation	Mode 2 Deviation	Mode 3 Deviation	Mode 4 Deviation	
40-41	42	43	44	45	46	47	48	49	50
Reference 1	Reference 2		Reference 3		Reference 4		Constant Level Switch	DCI Isolation	Voltage Monitoring Switch
51									
Current Monitoring Switch									
Remarks:									
● 1 register equals 2 bytes in length;									

		<ul style="list-style-type: none"> ● Specific register parameter nomenclature and value ranges can be found in the previous part of this section or in the introduction related to the measurement setup parameters; ● The length of data corresponding to a write operation must be 2 times the number of registers; ● The number of registers to be read or written can be from 1 to 45, and the instrument response starts from 1 and cannot be read or written from the center;
--	--	--

Function Code	Instruction Address	Number of data bytes Number of registers	Number of data	Data content	Command Function Description																																																																																																																								
Read/Write	High + Low	High + Low	Number of data	Address corresponds to setting value																																																																																																																									
R/W	0x1021	n	2n	...	Batch read/write of measurement related parameter settings																																																																																																																								
		<p>The parameters of the n registers (1~n) are as follows:</p> <table border="1"> <thead> <tr> <th>1</th><th>2</th><th>3</th><th>4</th><th>5</th><th>6</th><th>7</th><th>8</th><th>9</th><th>10</th></tr> </thead> <tbody> <tr> <td>Function 1</td><td>Function 2</td><td>Function 3</td><td>Function 4</td><td>Function 1 switch</td><td>Function 2 switch</td><td>Function 3 switch</td><td>Function 4 switch</td><td>AC Level Type</td><td>Speed</td></tr> <tr> <td>11</td><td>12</td><td>13</td><td>14</td><td>15</td><td>16</td><td>17</td><td>18</td><td>19</td><td>20</td></tr> <tr> <td>Range Auto Switch</td><td>AC Range</td><td>DC Range</td><td>Trigger Mode</td><td>Average Count</td><td>Bias Source</td><td>Bias Output Status</td><td>Bias Polarity</td><td>DC Bias Type</td><td>Bias Mode 1</td></tr> <tr> <td>21</td><td>22</td><td>23</td><td>24</td><td>25</td><td>26</td><td>27</td><td colspan="3"></td></tr> <tr> <td>Deviation Mode 2</td><td>Deviation Mode 3</td><td>Deviation Mode 4</td><td>Constant Level Switch</td><td>DCI Isolation</td><td>Voltage Monitor Switch</td><td>Current Monitor Switch</td><td colspan="3"></td></tr> <tr> <td>28</td><td>29</td><td>30</td><td>31</td><td>32</td><td>33</td><td>34</td><td>35</td><td>36</td><td>37</td></tr> <tr> <td colspan="2">Frequency</td><td colspan="2">AC Voltage</td><td colspan="2">AC Current</td><td colspan="2">DC Level</td><td colspan="2">Trigger Delay</td></tr> <tr> <td>38</td><td>39</td><td>40</td><td>41</td><td>42</td><td>43</td><td>44</td><td>45</td><td>46</td><td>47</td></tr> <tr> <td colspan="2">Step Delay</td><td colspan="2">DC Bias Voltage</td><td colspan="2">DC Bias Current</td><td colspan="2">Reference 1</td><td colspan="2">Reference 2</td></tr> <tr> <td>48</td><td>49</td><td>50</td><td>51</td><td></td><td></td><td></td><td></td><td></td><td></td></tr> <tr> <td colspan="2">Reference 3</td><td colspan="2">Reference 4</td><td></td><td></td><td></td><td></td><td></td><td></td></tr> </tbody> </table> <p>Remarks:</p> <ul style="list-style-type: none"> ● 1 register equals 2 bytes in length; ● Specific register parameter nomenclature and value ranges can be found in the previous part of this section or in the introduction related to measurement setup parameters; ● The length of data corresponding to a write operation must be 2 times the number of registers; ● The number of registers to be read or written can be from 1 to 45, and the response of the instrument is from 1, not from the middle of the read or write; 				1	2	3	4	5	6	7	8	9	10	Function 1	Function 2	Function 3	Function 4	Function 1 switch	Function 2 switch	Function 3 switch	Function 4 switch	AC Level Type	Speed	11	12	13	14	15	16	17	18	19	20	Range Auto Switch	AC Range	DC Range	Trigger Mode	Average Count	Bias Source	Bias Output Status	Bias Polarity	DC Bias Type	Bias Mode 1	21	22	23	24	25	26	27				Deviation Mode 2	Deviation Mode 3	Deviation Mode 4	Constant Level Switch	DCI Isolation	Voltage Monitor Switch	Current Monitor Switch				28	29	30	31	32	33	34	35	36	37	Frequency		AC Voltage		AC Current		DC Level		Trigger Delay		38	39	40	41	42	43	44	45	46	47	Step Delay		DC Bias Voltage		DC Bias Current		Reference 1		Reference 2		48	49	50	51							Reference 3		Reference 4							
1	2	3	4	5	6	7	8	9	10																																																																																																																				
Function 1	Function 2	Function 3	Function 4	Function 1 switch	Function 2 switch	Function 3 switch	Function 4 switch	AC Level Type	Speed																																																																																																																				
11	12	13	14	15	16	17	18	19	20																																																																																																																				
Range Auto Switch	AC Range	DC Range	Trigger Mode	Average Count	Bias Source	Bias Output Status	Bias Polarity	DC Bias Type	Bias Mode 1																																																																																																																				
21	22	23	24	25	26	27																																																																																																																							
Deviation Mode 2	Deviation Mode 3	Deviation Mode 4	Constant Level Switch	DCI Isolation	Voltage Monitor Switch	Current Monitor Switch																																																																																																																							
28	29	30	31	32	33	34	35	36	37																																																																																																																				
Frequency		AC Voltage		AC Current		DC Level		Trigger Delay																																																																																																																					
38	39	40	41	42	43	44	45	46	47																																																																																																																				
Step Delay		DC Bias Voltage		DC Bias Current		Reference 1		Reference 2																																																																																																																					
48	49	50	51																																																																																																																										
Reference 3		Reference 4																																																																																																																											

9.3.3.2 Comparison of Settings

Instrument Bus Address	Function Code	Command Address	Number of data bytes Number of registers	Number of data	Data content	Command Function Meaning				
Instrument Address	Read/Write	High + Low	High + Low	Number of data	Set value according to address					
	R/W	0x001A	0x0001	1	0~1	Compare Mode <table border="1"> <tr> <td>0</td> <td>TOL</td> </tr> <tr> <td>1</td> <td>SEQ</td> </tr> </table>	0	TOL	1	SEQ
0	TOL									
1	SEQ									
		0x001B				xx				
	R/W	0x001C	0x0001	1	0~1	Compare Switch <table border="1"> <tr> <td>0</td> <td>OFF</td> </tr> <tr> <td>1</td> <td>ON</td> </tr> </table>	0	OFF	1	ON
0	OFF									
1	ON									
	R/W	0x001D	0x0004	4	float	Bin 1 Low				
	R/W	0x001E	0x0004	4	float	Bin 1 High				
	R/W	0x001F	0x0004	4	float	Bin 2 Low				
	R/W	0x0020	0x0004	4	float	Bin 2 High				
	R/W	0x0021	0x0004	4	float	Bin 3 Low				
	R/W	0x0022	0x0004	4	float	Bin 3 High				
	R/W	0x0023	0x0004	4	float	Bin 4 Low				
	R/W	0x0024	0x0004	4	float	Bin 4 High				
	R/W	0x0025	0x0004	4	float	Bin 5 Low				
	R/W	0x0026	0x0004	4	float	Bin 5 High				
	R/W	0x0027	0x0004	4	float	Bin 6 Low				
	R/W	0x0028	0x0004	4	float	Bin 6 High				
	R/W	0x0029	0x0004	4	float	Bin 7 Low				
	R/W	0x002A	0x0004	4	float	Bin 7 High				
	R/W	0x002B	0x0004	4	float	Bin 8 Low				
	R/W	0x002C	0x0004	4	float	Bin 8 High				
	R/W	0x002D	0x0004	4	float	Bin 9 Low				
	R/W	0x002E	0x0004	4	float	Bin 9 High				
	R/W	0x002F	0x0004	4	float	Bin 10 Low				
	R/W	0x0030	0x0004	4	float	Bin 10 High				
	R/W	0x1004	0x0006	6	char+ char+	Bin 1~10 Lower limit Byte Meaning: bin index 0~9 abcd index 0~3 float that is numeric size				
	R/W	0x1005	0x0006	6	float	Bin 1~10 Upper limit Byte Meaning: bin index 0~9 abcd index 0~3				

						float that is numeric size
--	--	--	--	--	--	----------------------------

9.3.3.3 List Setting Related

Function Code	Instruction Address	Number of data bytes Number of registers	Number of data	Data content	Command Function Description																																				
Read/Write	High + Low	High + Low	Number of data	Address corresponds to setting value																																					
R/W	0x0050	0x0001	2	1~201	List Scan Points																																				
R/W	0x0051	0x0001	2	0~1	List Scanning Method <table border="1"> <tr> <td>0</td> <td>SEQ</td> </tr> <tr> <td>1</td> <td>STEP</td> </tr> </table>	0	SEQ	1	STEP																																
0	SEQ																																								
1	STEP																																								
R/W	0x0052																																								
R/W	0x0053	0x0001	2	0~200	Scan point index position in current setup																																				
R/W	0x0054																																								
R/W	0x0055	0x0004	4	float	List scan point frequency																																				
R/W	0x0056	0x0005	6	float+u16	List scan point AC level +0/1(v/i)																																				
R/W	0x0057																																								
R/W	0x0058	0x0005	6	float+u16	List scan point DC bias +0/1(v/i)																																				
R/W	0x005A	0x0001~0x0004	1~4	0~	Function, the parameter comparison table is as follows: <table border="1"> <tr> <td>0</td> <td>CP</td> <td>6</td> <td>X</td> <td>12</td> <td>Q</td> </tr> <tr> <td>1</td> <td>CS</td> <td>7</td> <td>G</td> <td>13</td> <td>dZ</td> </tr> <tr> <td>2</td> <td>LP</td> <td>8</td> <td>B</td> <td>14</td> <td>rZ</td> </tr> <tr> <td>3</td> <td>LS</td> <td>9</td> <td>Z</td> <td>15</td> <td>dY</td> </tr> <tr> <td>4</td> <td>RP</td> <td>10</td> <td>Y</td> <td>16</td> <td>rY</td> </tr> <tr> <td>5</td> <td>RS</td> <td>11</td> <td>D</td> <td>17</td> <td>RD</td> </tr> </table>	0	CP	6	X	12	Q	1	CS	7	G	13	dZ	2	LP	8	B	14	rZ	3	LS	9	Z	15	dY	4	RP	10	Y	16	rY	5	RS	11	D	17	RD
0	CP	6	X	12	Q																																				
1	CS	7	G	13	dZ																																				
2	LP	8	B	14	rZ																																				
3	LS	9	Z	15	dY																																				
4	RP	10	Y	16	rY																																				
5	RS	11	D	17	RD																																				
R/W	0x005C	0x0004	4	float	List Scan Point Step Delay																																				
R/W	0x1006	0x0006	6	char+ char+ float	Lower limit of list scan points Byte Meaning: Point Index 0~200 abcd index 0~3 float i.e. value size																																				
R/W	0x1007	0x0006	6		Upper limit of list scan points Byte meaning: Point index 0~200 abcd index 0~3 float i.e. value size																																				
R	0x100B	9*n			Read List All Test Results The number of registers read is n times 9 (i.e., n points) The data for a single point is composed as follows: <table border="1"> <tr> <td>2Reg</td> <td>2Reg</td> <td>2Reg</td> <td>2Reg</td> <td>1Reg</td> </tr> </table>	2Reg	2Reg	2Reg	2Reg	1Reg																															
2Reg	2Reg	2Reg	2Reg	1Reg																																					

					P1	P2	P3	P4	cmp																		
R	0x100C 0x100D 0x100E 0x100F	2*n			Read List Specified Parameters 1/2/3/4 Test Results The number of registers read is n times 2 (i.e., n points) The data of a single point is composed as follows: <table border="1" style="margin-left: 20px;"> <tr><td>2Reg</td></tr> <tr><td>Pn</td></tr> </table>					2Reg	Pn																
2Reg																											
Pn																											
R	0x1010	n			Read List Compare Results Reading the number of registers as n (i.e. n points) The data of a single point is composed as follows: cmp takes the value 0/1/2/... 0 - not compared, 1 ---- passes, others ---- fail <table border="1" style="margin-left: 20px;"> <tr><td>1Reg</td></tr> <tr><td>cmp</td></tr> </table>					1Reg	cmp																
1Reg																											
cmp																											
R	0x1011	4	8	short(0~3)	Setting the data size returned by the 4 parameters of the list The 4 words correspond to the 4-parameter report size settings; Value: 0 ---- default absolute data size; 1---- data x10 ³ after reporting; 2---- data x10 ⁶ after reporting;																						
Example: Write 08 10 10 11 00 04 08 00 00 00 00 00 00 00 00 00 7D D0 — Set all 4 parameters to 0 Write 08 10 10 11 00 04 08 00 01 00 01 00 01 00 01 C0 D0 ---- Set all 4 parameters to 1 Write 08 10 10 11 00 04 08 00 02 00 02 00 02 00 02 07 D1 ---- Set all 4 parameters to 2																											
R/W	0x3000	W(1+2n) R(2n)	W(1+2n) R(2n)	W(u16)+ n ↑ float	Batch Read and Write List Scan Point Frequency (Write register starts at pt; read register starts at 0) The first register, u16, indicates the start point index, pt, with a value from 0 to 200. The data for the write register is as follows: <table border="1" style="margin-left: 20px;"> <tr> <td>1Reg</td> <td>2Reg</td> <td>2Reg</td> <td>...</td> <td>2Reg</td> </tr> <tr> <td>Starting pt</td> <td>f[pt]</td> <td>f[pt+1]</td> <td>...</td> <td>f[pt+n-1]</td> </tr> </table> The data of the read register is composed as follows: <table border="1" style="margin-left: 20px;"> <tr> <td>2Reg</td> <td>2Reg</td> <td>...</td> <td>2Reg</td> </tr> <tr> <td>f[0]</td> <td>f[1]</td> <td>...</td> <td>f[n-1]</td> </tr> </table>					1Reg	2Reg	2Reg	...	2Reg	Starting pt	f[pt]	f[pt+1]	...	f[pt+n-1]	2Reg	2Reg	...	2Reg	f[0]	f[1]	...	f[n-1]
1Reg	2Reg	2Reg	...	2Reg																							
Starting pt	f[pt]	f[pt+1]	...	f[pt+n-1]																							
2Reg	2Reg	...	2Reg																								
f[0]	f[1]	...	f[n-1]																								
R/W	0x3001	W(1+2n) R(2n)	W(1+2n) R(2n)	W(u16)+ n ↑ float	Batch read and write list Scan point level voltage Read and write description is the same as address 0x3000 Frequency description																						
R/W	0x3002	W(1+2n) R(2n)	W(1+2n) R(2n)	W(u16)+ n ↑ float	Read and write the scan point level current in the batch read and write list Read and write description: Same as address 0x3000 Frequency description																						
R/W	0x3003	W(1+2n)	W(1+2n)	W(u16)+	Read and write the scan point offset voltage in the batch																						

		R(2n)	R(2n)	n ↑ float	read and write list Read and write description: Same as address 0x3000 Frequency description																										
R/W	0x3004	W(1+2n) R(2n)	W(1+2n) R(2n)	W(u16)+ n ↑ float	Read and write the scan point offset current in the batch read and write list Read and write description: Same as address 0x3000 Frequency description																										
R/W	0x3005	W(1+2n) R(2n)	W(1+2n) R(2n)	W(u16)+ n ↑ float	Read and write the scan point step delay in the batch read and write list Read and write description: Same as address 0x3000 Frequency description																										
R/W	0x3006 0x3007 0x3008 0x3009	W(1+2n) R(2n)	W(1+2n) R(2n)	W(u16)+ n ↑ float	The upper limit of batch read and write list scan points corresponds to the following 4-parameter relationship: <table border="1"> <tr> <td>0x3006</td> <td>0x3007</td> <td>0x3008</td> <td>0x3009</td> </tr> <tr> <td>Parameter 1(A)</td> <td>Parameter 2(B)</td> <td>Parameter 3(C)</td> <td>Parameter 4(D)</td> </tr> </table> Read and write description with address 0x3000 Frequency description	0x3006	0x3007	0x3008	0x3009	Parameter 1(A)	Parameter 2(B)	Parameter 3(C)	Parameter 4(D)																		
0x3006	0x3007	0x3008	0x3009																												
Parameter 1(A)	Parameter 2(B)	Parameter 3(C)	Parameter 4(D)																												
R/W	0x300A 0x300B 0x300C 0x300D	W(1+2n) R(2n)	W(1+2n) R(2n)	W(u16)+ n ↑ float	The lower limit of the batch read/write list scan point address corresponds to the 4-parameter relationship as follows: <table border="1"> <tr> <td>0x300A</td> <td>0x300B</td> <td>0x300C</td> <td>0x300D</td> </tr> <tr> <td>Parameter 1(A)</td> <td>Parameter 2(B)</td> <td>Parameter 3(C)</td> <td>Parameter 4(D)</td> </tr> </table> Read/write description same as address 0x3000 Frequency description	0x300A	0x300B	0x300C	0x300D	Parameter 1(A)	Parameter 2(B)	Parameter 3(C)	Parameter 4(D)																		
0x300A	0x300B	0x300C	0x300D																												
Parameter 1(A)	Parameter 2(B)	Parameter 3(C)	Parameter 4(D)																												
R/W	0x300E 0x300F 0x3010 0x3011	W(1+n) R(n)	W(1+n) R(n)	W(u16)+ n ↑ u16	Batch Read/Write List Scan Point Function The address corresponds to the 4-parameter relationship as follows: <table border="1"> <tr> <td>0x300E</td> <td>0x300F</td> <td>0x3010</td> <td>0x3011</td> </tr> <tr> <td>Parameter 1(A)</td> <td>Parameter 2(B)</td> <td>Parameter 3(C)</td> <td>Parameter 4(D)</td> </tr> </table> (Write registers start at point pt; read registers start at point 0) The first register u16 indicates the starting point index pt and takes the value 0~200. The data of the write register is composed as follows: <table border="1"> <tr> <td>1Reg</td> <td>1Reg</td> <td>1Reg</td> <td>...</td> <td>1Reg</td> </tr> <tr> <td>Starting pt</td> <td>func[pt]</td> <td>func[pt+1]</td> <td>...</td> <td>func[pt+n-1]</td> </tr> </table> The data of the read register is composed as follows: <table border="1"> <tr> <td>2Reg</td> <td>2Reg</td> <td>...</td> <td>2Reg</td> </tr> <tr> <td>func[0]</td> <td>func[1]</td> <td>...</td> <td>func[n-1]</td> </tr> </table>	0x300E	0x300F	0x3010	0x3011	Parameter 1(A)	Parameter 2(B)	Parameter 3(C)	Parameter 4(D)	1Reg	1Reg	1Reg	...	1Reg	Starting pt	func[pt]	func[pt+1]	...	func[pt+n-1]	2Reg	2Reg	...	2Reg	func[0]	func[1]	...	func[n-1]
0x300E	0x300F	0x3010	0x3011																												
Parameter 1(A)	Parameter 2(B)	Parameter 3(C)	Parameter 4(D)																												
1Reg	1Reg	1Reg	...	1Reg																											
Starting pt	func[pt]	func[pt+1]	...	func[pt+n-1]																											
2Reg	2Reg	...	2Reg																												
func[0]	func[1]	...	func[n-1]																												

]				
function with the following parameter cross-reference func:									
0	CP	6	X	12	Q				
1	CS	7	G	13	dZ				
2	LP	8	B	14	rZ				
3	LS	9	Z	15	dY				
4	RP	10	Y	16	rY				
5	RS	11	D	17	RD				
Function data is hexadecimal									

9.3.3.4 Curve Setting Related

Instrument Bus Address	Function Code	Command Address	Number of data bytes Number of registers	Number of data	Data content	Command Function Meaning										
Instrument Address	Read/Write	High + Low	High + Low	Number of data	Set value according to address											
	R/W	0x0090	0x0001	1	0~1	LCR Curve ---- Scale <table border="1"> <tr> <td>0</td> <td>AUTO</td> </tr> <tr> <td>1</td> <td>HOLD</td> </tr> </table>	0	AUTO	1	HOLD						
0	AUTO															
1	HOLD															
	R/W	0x0092	0x0001	1	0~1	LCR Curve ---- Coordinates <table border="1"> <tr> <td>0</td> <td>线性</td> </tr> <tr> <td>1</td> <td>对数</td> </tr> </table>	0	线性	1	对数						
0	线性															
1	对数															
	R/W	0x0094	0x0001	1	0~1	LCR Curve ---- Curve Mode <table border="1"> <tr> <td>0</td> <td>SEQ</td> </tr> <tr> <td>1</td> <td>STEP</td> </tr> </table>	0	SEQ	1	STEP						
0	SEQ															
1	STEP															
	R/W	0x0096	0x0001	1	0~4	LCR Curves ---- Points <table border="1"> <tr> <td>0</td> <td>51</td> </tr> <tr> <td>1</td> <td>101</td> </tr> <tr> <td>2</td> <td>201</td> </tr> <tr> <td>3</td> <td>401</td> </tr> <tr> <td>4</td> <td>801</td> </tr> </table>	0	51	1	101	2	201	3	401	4	801
0	51															
1	101															
2	201															
3	401															
4	801															
	R/W	0x0097	0x0001	1	0~1	LCR Curve ---- Extreme <table border="1"> <tr> <td>0</td> <td>OFF</td> </tr> <tr> <td>1</td> <td>ON</td> </tr> </table>	0	OFF	1	ON						
0	OFF															
1	ON															
	R/W	0x0098	0x0001	1	float	LCR Curve ---- Start Size										
	R/W	0x0099	0x0001	1	float	LCR curve ---- End size										

9.3.3.5 User Zero Related

Instrument Bus Address	Function Code	Command Address	Number of data bytes Number of registers	Number of data	Data content	Command Function Meaning										
Instrument Address	Read/Write	High + Low	High + Low	Number of data	Set value according to address											
	R/W	0x0031	0x0001	2	0~3	Open circuit function <table border="1"> <tr><td>0</td><td>OFF</td></tr> <tr><td>1</td><td>ON</td></tr> <tr><td>2</td><td>Full Frequency Open Circuit Zeroing</td></tr> <tr><td>3</td><td>DCR Zeroing</td></tr> </table>	0	OFF	1	ON	2	Full Frequency Open Circuit Zeroing	3	DCR Zeroing		
0	OFF															
1	ON															
2	Full Frequency Open Circuit Zeroing															
3	DCR Zeroing															
	R/W	0x0032	0x0001	2	0~3	Short circuit function <table border="1"> <tr><td>0</td><td>OFF</td></tr> <tr><td>1</td><td>ON</td></tr> <tr><td>2</td><td>Full Frequency Short Circuit Zeroing</td></tr> <tr><td>3</td><td>DCR Zeroing</td></tr> </table>	0	OFF	1	ON	2	Full Frequency Short Circuit Zeroing	3	DCR Zeroing		
0	OFF															
1	ON															
2	Full Frequency Short Circuit Zeroing															
3	DCR Zeroing															
	R/W	0x0033	0x0001	2	0~1	Load Function										
	R/W	0x0034	0x0001	2	0~1	Cable Length										
	R/W	0x0035														
	R/W	0x0036	0x0001	2	0~9	Calibration Point										
	R/W	0x0037	0x0002	4	float	Frequency Setting										
	R/W	0x0038	0x0001	2	0~4	Frequency Point Switch <table border="1"> <tr><td>0</td><td>OFF</td></tr> <tr><td>1</td><td>ON</td></tr> <tr><td>2</td><td>Single-frequency Open-circuit Clearing</td></tr> <tr><td>3</td><td>Single-frequency Short-circuit Clearing</td></tr> <tr><td>4</td><td>Single-frequency Load</td></tr> </table>	0	OFF	1	ON	2	Single-frequency Open-circuit Clearing	3	Single-frequency Short-circuit Clearing	4	Single-frequency Load
0	OFF															
1	ON															
2	Single-frequency Open-circuit Clearing															
3	Single-frequency Short-circuit Clearing															
4	Single-frequency Load															
	R/W	0x0039	0x0002	4	float	Reference A for calibration point										
	R/W	0x003A	0x0002	4	float	Reference B for calibration point										

9.3.3.6 System Setup Related

Instrument Bus Address	Function Code	Command Address	Number of data bytes Number of registers	Number of data	Data content	Command Function Meaning																																																								
Instrument Address	Read/Write	High + Low	High + Low	Number of data	Set value according to address																																																									
	W	0x0040	0x0001	1	1	Start test (Trigger key function)																																																								
	W	0x0041	0x0001	1	1	Stop test (Reset key function)																																																								
	R	0x0042				Read the results																																																								
	R/W	0x0043	0x0001	1	char	<p>page switch, the char parameter value range is as follows:</p> <table border="1"> <tr> <td>0</td> <td>Measurement</td> <td>1</td> <td>List</td> </tr> <tr> <td>2</td> <td>Curves</td> <td>3</td> <td>Measurement Settings</td> </tr> <tr> <td>4</td> <td>Limit Setting</td> <td>5</td> <td>List Settings</td> </tr> <tr> <td>6</td> <td>Curve Settings</td> <td>7</td> <td>System Settings</td> </tr> <tr> <td>8</td> <td>File Management</td> <td>9</td> <td>User Zeroing</td> </tr> <tr> <td>10</td> <td>Handler</td> <td></td> <td></td> </tr> <tr> <td>11</td> <td>Single Group Testing</td> <td>12</td> <td>Single Group Setting</td> </tr> <tr> <td>15</td> <td>TRS Scan</td> <td>16</td> <td>TRS id</td> </tr> <tr> <td>17</td> <td>Pin Correlation</td> <td>18</td> <td>1831 Scan</td> </tr> <tr> <td>19</td> <td>1901 Scan</td> <td>20</td> <td>Pin Setting</td> </tr> <tr> <td>21</td> <td>Condition Setting</td> <td>22</td> <td>Deviation Deduction</td> </tr> <tr> <td>23</td> <td>Quick Setup</td> <td>24</td> <td>Statistics</td> </tr> <tr> <td>25</td> <td>Tools</td> <td>26</td> <td>Scanning Self-test</td> </tr> <tr> <td>27</td> <td>Scan Hand</td> <td></td> <td></td> </tr> </table>	0	Measurement	1	List	2	Curves	3	Measurement Settings	4	Limit Setting	5	List Settings	6	Curve Settings	7	System Settings	8	File Management	9	User Zeroing	10	Handler			11	Single Group Testing	12	Single Group Setting	15	TRS Scan	16	TRS id	17	Pin Correlation	18	1831 Scan	19	1901 Scan	20	Pin Setting	21	Condition Setting	22	Deviation Deduction	23	Quick Setup	24	Statistics	25	Tools	26	Scanning Self-test	27	Scan Hand		
0	Measurement	1	List																																																											
2	Curves	3	Measurement Settings																																																											
4	Limit Setting	5	List Settings																																																											
6	Curve Settings	7	System Settings																																																											
8	File Management	9	User Zeroing																																																											
10	Handler																																																													
11	Single Group Testing	12	Single Group Setting																																																											
15	TRS Scan	16	TRS id																																																											
17	Pin Correlation	18	1831 Scan																																																											
19	1901 Scan	20	Pin Setting																																																											
21	Condition Setting	22	Deviation Deduction																																																											
23	Quick Setup	24	Statistics																																																											
25	Tools	26	Scanning Self-test																																																											
27	Scan Hand																																																													
	R/W	0x0045	0x0001	1	0~1	<p>Key Sound</p> <table border="1"> <tr> <td>0</td> <td>OFF</td> </tr> <tr> <td>1</td> <td>ON</td> </tr> </table>	0	OFF	1	ON																																																				
0	OFF																																																													
1	ON																																																													
	R/W	0x0046	0x0001	1	0~4	Qualified Signal																																																								

						0	OFF	
						1	Two short	
						2	Two high	
						3	High/Short	
						4	High/Long	
	R/W	0x0047	0x0001	1	0~4	Bad Signal		
						0	OFF	
						1	Two short	
						2	Two high	
						3	High/Short	
						4	High/Long	
	R/W	0x0048	0x0001	1	0~1	Display Language		
						0	English	
						1	Chinese	
	R/W	0x004E	0x0001	1	0~2	Bias Source		
						0	100mA	
						1	2A	
						2	External TH1778	

9.3.3.7 File Related

Instrument Bus Address	Function Code	Command Address	Number of data bytes Number of registers	Number of data	Data content	Command Function Meaning				
Instrument Address	Read/Write	High + Low	High + Low	Number of data	Set value according to address					
Test Data Save Switch										
	W	0x1008	0x0001	1	char(0~1)	Test result USB flash drive save switch setting <table border="1"> <tr> <td>0</td> <td>OFF</td> </tr> <tr> <td>1</td> <td>ON</td> </tr> </table>	0	OFF	1	ON
0	OFF									
1	ON									
	W	0x1009	0x0001	1	char(0~1)	List results of USB flash drive save switch settings <table border="1"> <tr> <td>0</td> <td>OFF</td> </tr> <tr> <td>1</td> <td>ON</td> </tr> </table>	0	OFF	1	ON
0	OFF									
1	ON									
	W	0x100A	0x0001	1	char(0~1)	Curve result USB flash drive save switch setting <table border="1"> <tr> <td>0</td> <td>OFF</td> </tr> <tr> <td>1</td> <td>ON</td> </tr> </table>	0	OFF	1	ON
0	OFF									
1	ON									
Configuration File Loading Calls										

	R/W	0x2005	0x0001	2	char(0~50)	<p>Load the specified file in the internal files directory.</p> <p>The value of n ranges from 0 to 50.</p> <p>Specifies a file in the files root directory in the following format:</p> <table border="1"> <tr> <td>LCR Bridge</td> <td>LCR1.sta ,LCR2.sta , LCR3.sta , LCRn.sta</td> </tr> <tr> <td>Transformer Single Group</td> <td>TRT1.trt , TRT2.trt , TRT3.trt , TRTn.trt</td> </tr> <tr> <td>Transformer Scanning</td> <td>TRS1.t40 ,TRS2.t40 , TRS3.t40 , TRSn.t40</td> </tr> </table> <p>Reading this register means querying whether an internal file has been loaded, and if so, returning the size of n (2 bytes in length) corresponding to its presence in the data;</p> <p>If there is no internal file being loaded, then no n is returned, and the return: 08 03 00 F0 F2</p>	LCR Bridge	LCR1.sta ,LCR2.sta , LCR3.sta , LCRn.sta	Transformer Single Group	TRT1.trt , TRT2.trt , TRT3.trt , TRTn.trt	Transformer Scanning	TRS1.t40 ,TRS2.t40 , TRS3.t40 , TRSn.t40
LCR Bridge	LCR1.sta ,LCR2.sta , LCR3.sta , LCRn.sta											
Transformer Single Group	TRT1.trt , TRT2.trt , TRT3.trt , TRTn.trt											
Transformer Scanning	TRS1.t40 ,TRS2.t40 , TRS3.t40 , TRSn.t40											
	W	0x2006	0x0001	2	char(0~50)	<p>Load the specified file in the usb directory of the flash drive.</p> <p>n value range: 0~50</p> <p>Specify the file in the usb root directory in the same format as above.</p>						

9.4 Examples of Writing Commands

9.4.1 Example of Curve Scan Commands

Step	Command	Description
1	DISP:PAGE TSME	Go to the curve page
	TRIG:SOUR SING	Setting the Single Trigger
	FREQ 1000	Set the common frequency; the sweep frequency is also determined by the start and end points.
	VOLT 1	Set the test AC level
	BIAS:VOLT 0	Set the bias voltage, if you need to add

			bias, you must send the bias open switch control BIAS:STAT ON before the test and the close command BIAS:STAT OFF after the test.
2	Curve Parameters	TSSE:POINT 101	Setting the Number of Points
		TSSE:SMODE SEQ	Setting the Continuous Scan Mode
		TSSE:MODE FREQ	Set the scan object to frequency, i.e., horizontal coordinate.
		TSSE:FORM LIN	Set the point distribution mode to linear.
		TSSE:SWEEP 1e3,1e6	Set the start and end points of the horizontal coordinate.
		TSSE:IMP Z,CS,LS,D	Set the result parameters for the 4 vertical coordinates
		The above is part of the initialization	
3	Trigger Test	TRIG	Run a test
		TRIG:STAT? Returns RUN 0 or RUN 1	Query the test status, the test is not 1, the end of the test is 0.
4	Query Result	Read test results after the query reaches RUN 0.	Query the test results, see the section on Query Curve Scanning Results, query the required data as needed (because of the large amount of data).
		FETCH:TRACE:Y1?	For example, query the results of all points of parameter 1.
		FETCH:TRACE:Y3?	For example, query all points of parameter 3.

9.4.2 Examples of Transformer Test Commands

Step		Command	Description
1	Trigger Test	TRIG	Run the test once
		TRIG:STAT? Returns RUN 0 or RUN 1	Query the status of the test, the test is not 1, the end of the test is 0
2	Query Results	Read test results after the query reaches RUN 0.	Query the test results, see the section on Query Curve Scan Results, and query the required data as needed (because the amount of data is large).
		TRS:AFET?	For example, the ASCII data corresponding to a measurement object.
		TRS:DATA?	For example, the hexadecimal results corresponding to all points (untested points

			are automatically padded with 0).
		Other query commands	See sections 9.2.20 and 9.2.16.

Chapter 10 Description for Handler

TH2840 series instruments provide users with a Handler interface, which is mainly used for the output of instrument sorting results. When the instrument is used in the automatic component sorting test system, this interface provides the communication signal with the system and the sorting result output signal.

The bin sorting and list sweep sorting of TH2840 series instrument bridge module uses the 57BR-4036L interface;

The transformer single group test sorting of TH2840 series uses 57BR-4036L interface output;

The transformer scanning (built-in scanning board) sorting of TH2840 series uses two DR-25P-bend hole interface output;

The transformer scanning (external scanning box) sorting of TH2840 series uses the DR-25P-bend hole interface output that comes with the scanning box.

For the specific location of the interface, refer to the introduction of the rear panel in Chapter 2. HANDLER interface design is flexible, after using different operating procedures, all output signal states are defined according to the requirements of use.

10.1 Bin Sorting Handler Description

The interface model provided by the bin sorting instrument is 57BR-4036L, which provides /BIN1-/BIN10 ten-bin sorting and total PASS and FAIL signals.

10.1.1 Technology Description

10.1.1.1 Output Signal

Active low (default), open collector, optoelectronic isolation

Table 10-1 Output signal

Signal	Overview
/BIN1-/BIN10 PASS, FAIL	Result output
/INDEX	"Analog measurement end" signal
/EOM	"End of all measurements" signal
/ALARM	Provides an alert when a momentary power failure or processor interface board reset is detected.

10.1.1.2 Input Signal

Optoelectronic isolation

Table 10-2 Input signal

Signal	Overview
/KEY_LOCK	Key lock (locks the front panel keyboard, including the touch screen)
/EXT_TRIG	External Trigger: pulsewidth $\geq 1\mu\text{S}$

10.1.1.3 Signal Line Description

The Handler interface has 3 signal: comparison output, control output and control input. The following are the signal definitions of the HANDLER interface when the bin comparison function is used.

Compare output signal: /BIN1 - /BIN10, PASS, FAIL.

Control output signal: /INDEX (analog measurement end signal)

/EOM (measurement end and comparison data valid signal)

/ALARM (instrument power down signal).

Control input signal: /EXT.TRIG (external trigger signal)

/Keylock.

The interface diagram of the above pins is shown in Figure 10-1.

See Table 10-3 for the signal assignment and brief description of the above pins.

The timing diagram is shown in Figure 10-3.

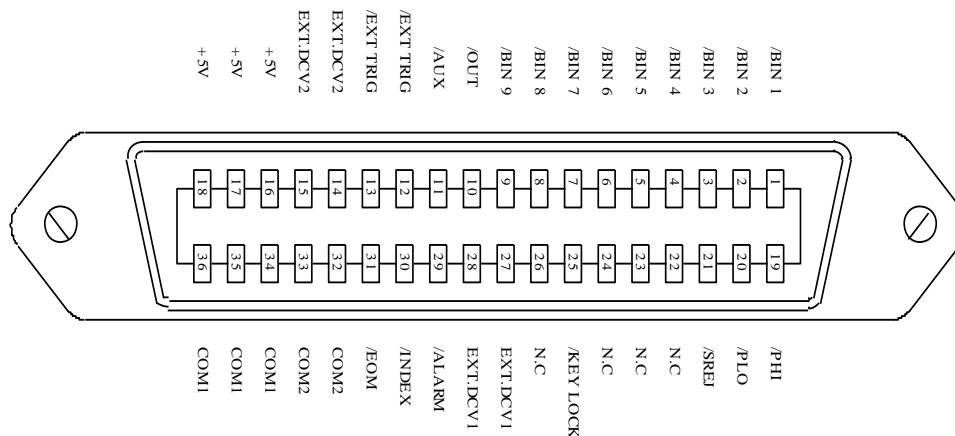

Figure 10-1 HANDLER connection interface pin definition

Note: Figure 10-1 is just the interface definition of the bin sorting, and the definition of the list sweep sorting and the transformer single test sorting are different.

Table 10-3 Signal distribution table for the pins comparison function:

Pin	Singal	Signal direction	Description
1	/BIN1	Output	BIN sorted result All/BIN(BIN number) output are all open collector output.
2	/BIN2		
3	/BIN3		
4	/BIN4		
5	/BIN5		
6	/BIN6		

7	/BIN7		
8	/BIN8		
9	/BIN9		
10	/BIN10		
11	Undefined	Output	Factory test signal, please do not connect
12 13	/EXT.TRIG	Input	External trigger: when the trigger mode is Single, TH2840 will be triggered by the positive-edge in this pin.
14 15	EXT.DCV2	Input	External DC voltage 2: The DC provider pin for the optoelectronic coupling signal(/EXT_TRIG, /KeyLock, /ALARM, /INDEX, /EOM)
16 17 18	+5V	Output	The internal power +5V: to use the internal power is not recommended. If you use the internal power, please ensure that the current is lower than 0.3A and the signal line is far from the disturbance source.
19	/PASS	Output	As long as the measurement result is in any one of /BIN1-/BIN10, it will be /PASS (see Figure 10-2).
20	/FAIL	Output	If the measurement result is not in any one of /BIN1-/BIN10, it will be /FAIL (see Figure 10-2).
21 22 23 24	Undefined	Output	Factory test signal, please do not connect
25	/KEY LOCK	Input	When this single is effective, all the front panel function keys and touch screen of TH2840 are locked and no longer work.
27 28	EXT.DCV1	Input	The external DC voltage 1: the pull-up DC power provider pin for optoelectronic coupling signal (/BIN-/BIN10, /PASS,/FAIL).
29	/ALARM	Output	When circuit is interrupted, /ALARM is effective.

30	/INDEX	Output	When the analog test is finished and the UNKNOWN terminal can be connected to another DUT, /INDEX is effective. But the comparison signal is effective until /EOM is effective.
31	/EOM	Output	End Of Measurement: That is, the measurement data and comparison results have been updated. (See Figure 10-3)
32,33	COM2	---	The reference ground for external power EXTV2.
34,35,36	COM1	---	The reference ground for external power EXTV1.

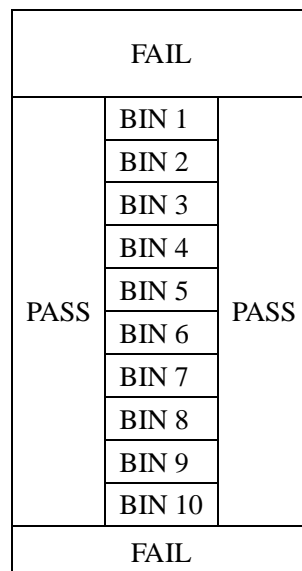

Figure 10-2 Example of the distribution area of the comparison function signals /PASS and /FAIL

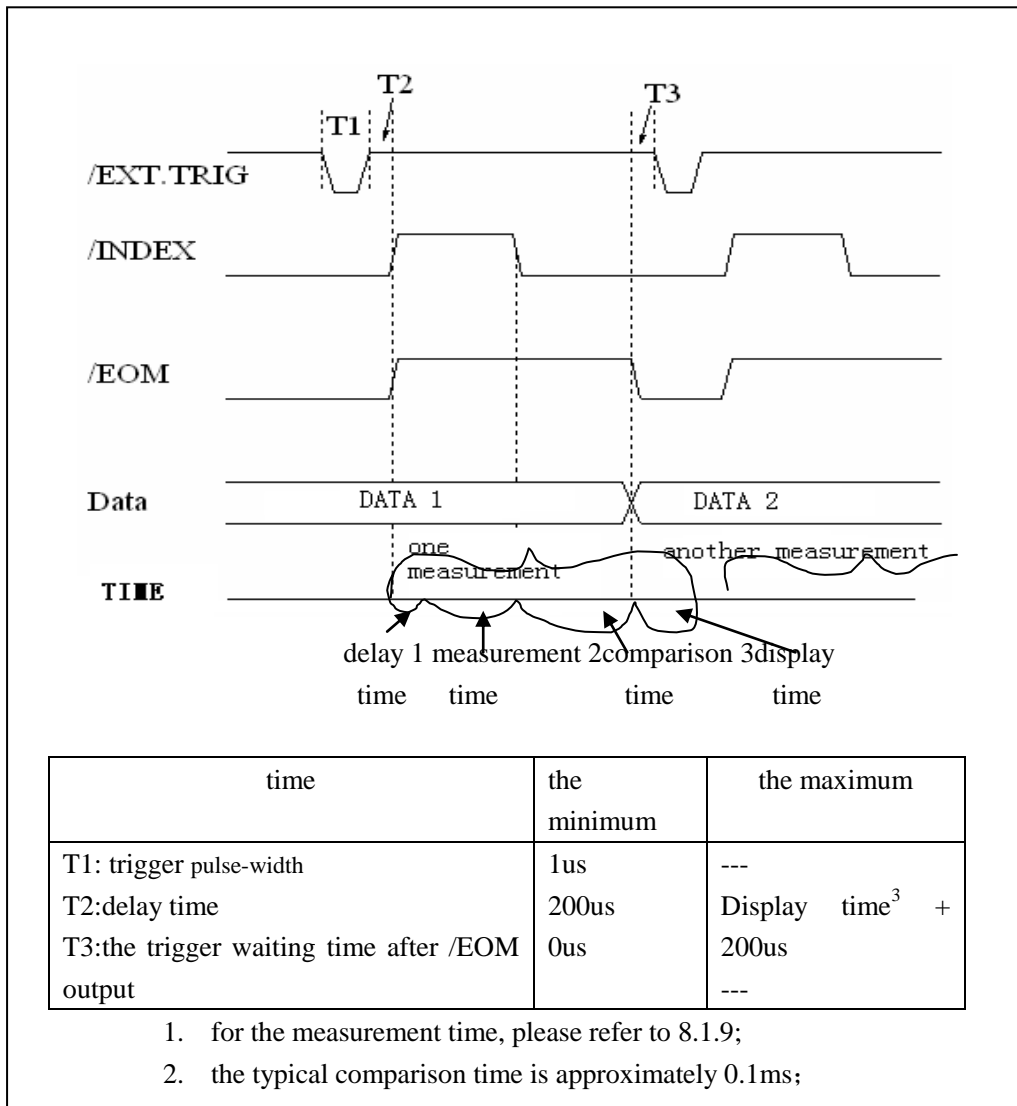

Figure 10-3 the timing chart

10.1.2 Electrical feature

As it is shown above, the signal definition for the comparison and the list sweep comparison are different. But the electrical feature is same. So the description can be applied to BIN comparison and list sweep comparison.

10.1.2.1 DC isolation output signal

Each DC output (pin 1 to 11, 19 to 24, and 29 to 31) is isolated via an open collector optocoupler output. The output voltage of each line is set by a pull-up resistor on the HANDLER interface board. The pull-up resistor is connected with the internal supply voltage (+5V) or with the external supply voltage (EXTV: +5V-24V) by jumper.

The DC isolated output signal utilizes a dedicated electrical system which is independent of the control output signal. Therefore, the processor board has a common line for two separate circuits: COM1 and COM2.

The electrical characteristics of the DC isolated output are divided into two types, see Table 10-4. The output circuit configuration of the test result output signal is shown in Figure 10-5, and the output circuit configuration of the control output signal is shown in Figure 10-4.

Table 4 the electrical feature of the DC isolation output

Output signal	Output rated voltage		Maximum current	Reference ground for the circuit
	LOW	HIGH		
Compared signal /BIN1 - /BIN10 /PASS /FAIL	$\leq 0.5V$	+5V--+24V	6mA	Internal pull-up voltage: TH2840 GND EXTV1: COM1
Control signal /INDEX /EOM /ALARM	$\leq 0.5V$	+5V--+24V	5mA	Internal pull-up voltage : TH2840 GND EXTV2 : COM2

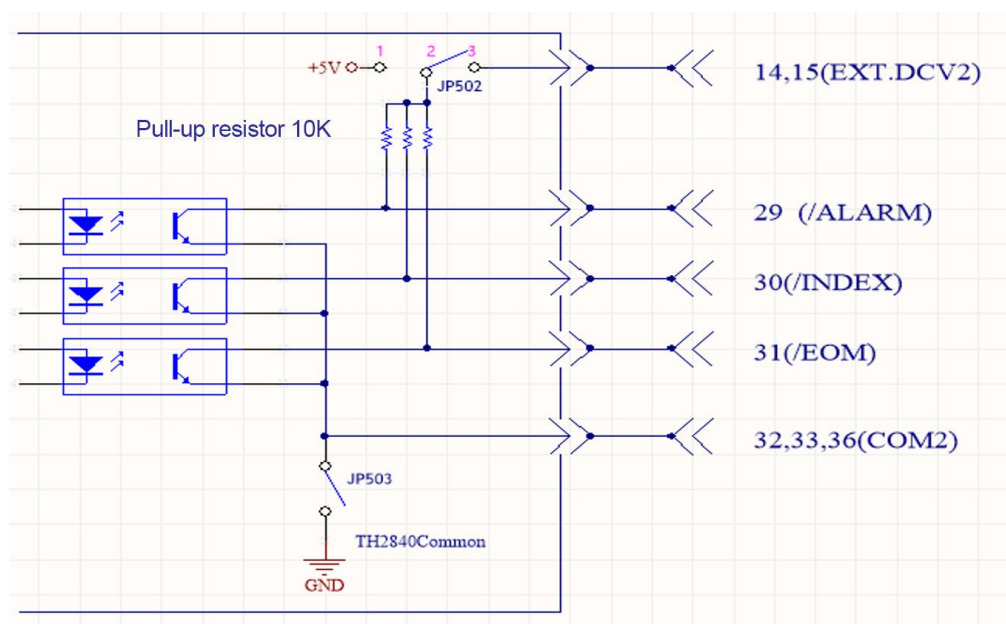

Figure 10-4 Control signal output circuit

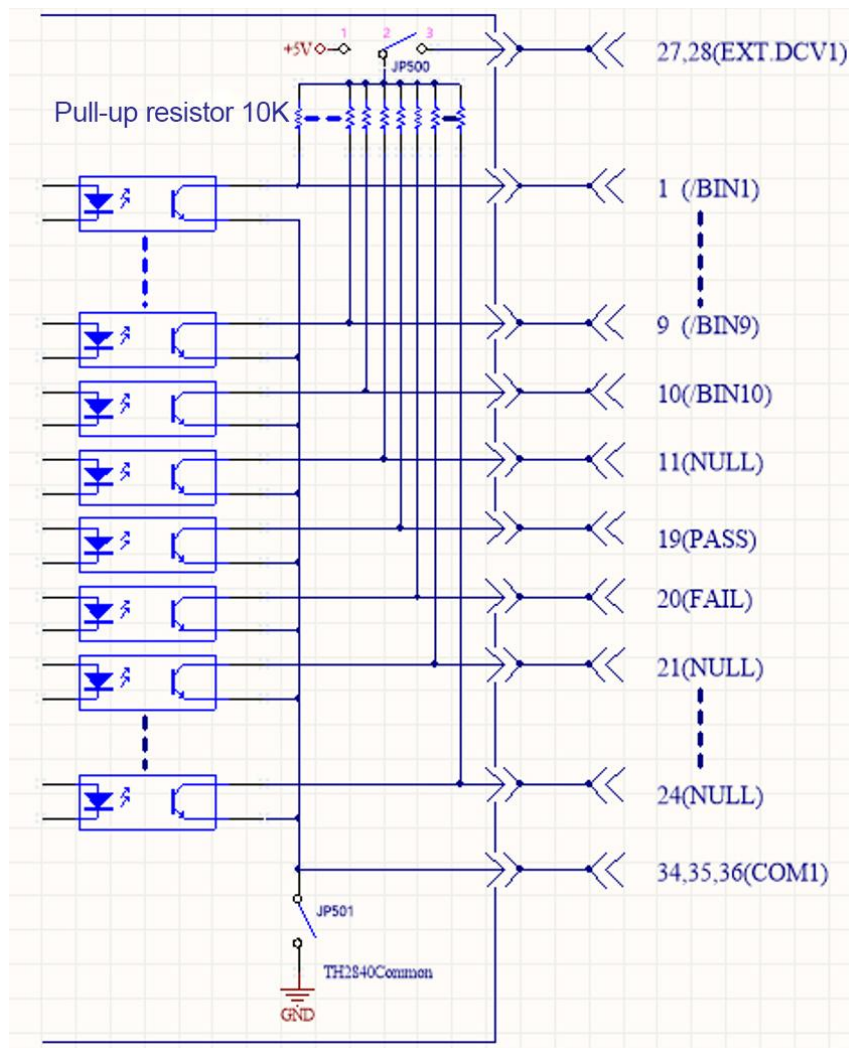

Figure 10-5 Comparison result signal output circuit

10.1.2.2 DC Isolation Input Signal

DC isolation input signals include the /EXT_TRIG and /KEY_LOCK signals.

The /EXT_TRIG signal (pin 12 and pin 13) is input to the LED cathode side of the optocoupler.

The instrument is triggered when the signal increases from LOW to HIGH. The optocoupler LED (anode side) can be driven by an internal pull-up voltage (+5 V) or an external voltage (EXT.DCV2).

The /KEY_LOCK signal (pin 25) is input to the optocoupler LED (on the cathode side). As long as this is low level, the keys on the front panel of the instrument will all be locked. The optocoupler LED (anode side) can be driven by internal voltage (+5V) or external voltage (EXT.DCV2).

The input circuit configuration of the DC isolation input signal is shown in Figure 10-6.

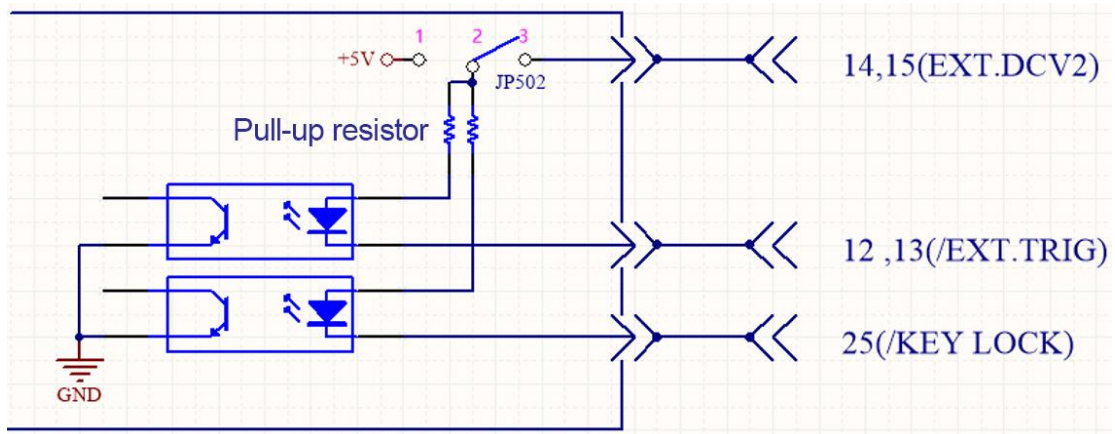

Figure 10-6 Input signal circuit configuration

10.1.3 Handler Wiring Operation Instructions of BIN Sorting

This section focuses on an example of the wiring between TH2840 and a typical PLC. The wiring example only introduces the wiring of two PLCs, that is, the PLC input circuit common anode and the PLC input circuit common cathode. For PLCs with other types of input circuits, you can consult our after-sales service.

The PLC input circuit common anode means that the current flows in from the common terminal of the module and flows out from the input channel of the module, which is often referred to as the source wiring method.

The PLC input circuit common cathode means that the current flows in from the input channel of the module and flows out from the common terminal of the module, which is often referred to as the drain wiring method.

When using bin sorting, PLC wiring diagram where handler interface and input circuit are common anode is shown in Figure 10-7, and PLC wiring diagram where handler interface and input circuit are common cathode is shown in Figure 10-8.

The factory default of TH2840 series instrument is external power supply. That is, pins 2 and 3 of JP500 are short-circuited, pins 2 and 3 of JP502 are short-circuited, JP501 is open, and JP503 is open. Therefore, be sure to connect the power supply to the external power supply pin when using it. If you need to use the internal power supply of the instrument, you need to change the jumper mode of JP500-JP503, please consult our after-sales service for details.

Note: 16, 17, and 18 are the 5V power supply inside the instrument and cannot be connected to any external power supply, otherwise the instrument will be damaged.

Considering the anti-interference ability of the instrument, TH2840 recommends users to provide and use an external power supply as the pull-up power supply for the optocoupler.

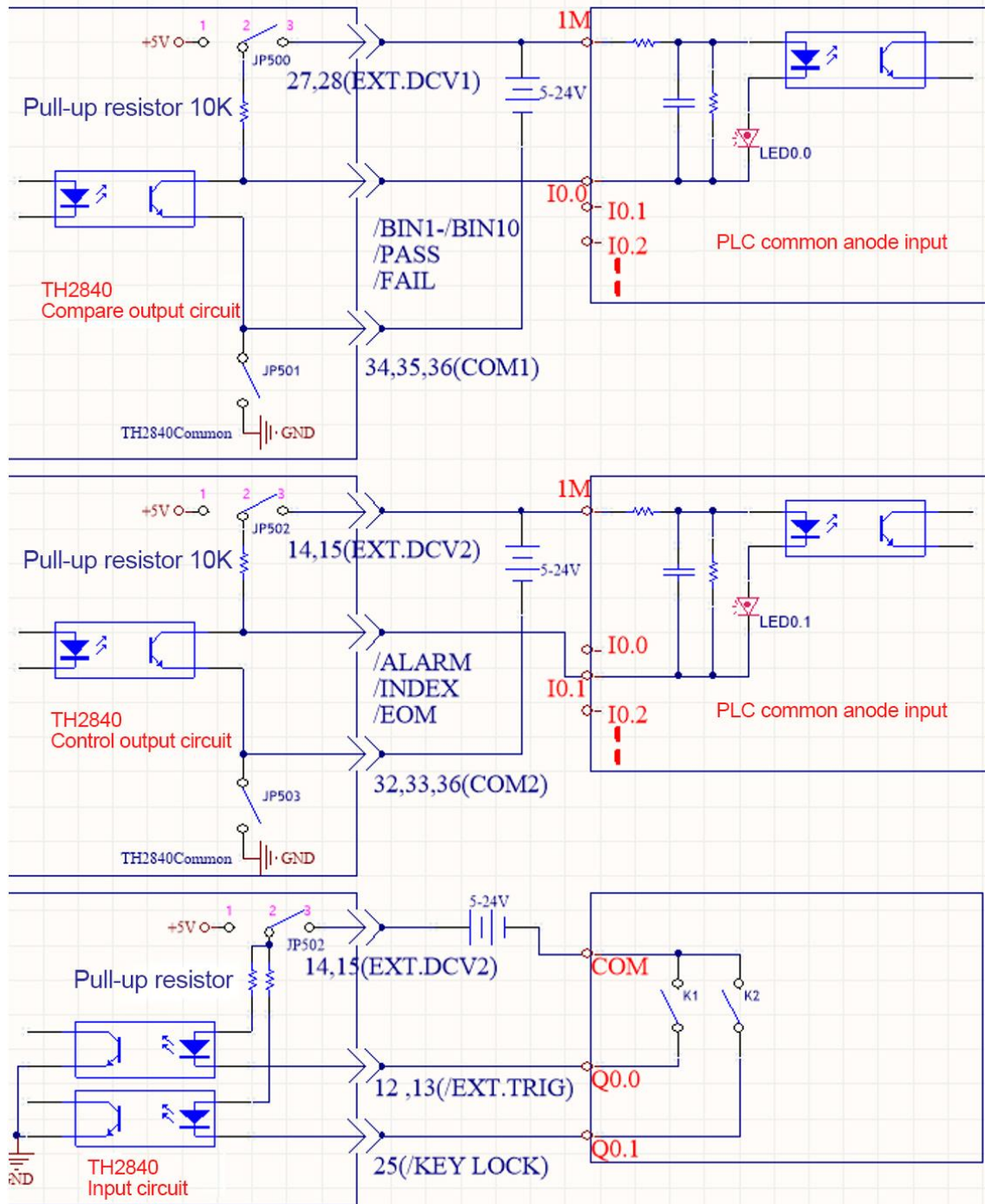

Figure 10-7 PLC wiring diagram where handler interface and input circuit are common anode
 Figure 10-7 Description: EXT.DCV1 and EXT.DCV2 can use the same set of external power supplies, or they can use different sets of power supplies. The corresponding low end of EXT.DCV1 is COM1, and the corresponding low end of EXT.DCV2 is COM2. The input circuit and the control output circuit use the same group of power supplies, namely EXT.DCV2. The wiring method provided in this figure is a typical connection method, and it needs to be flexibly applied according to the actual situation in practical application.

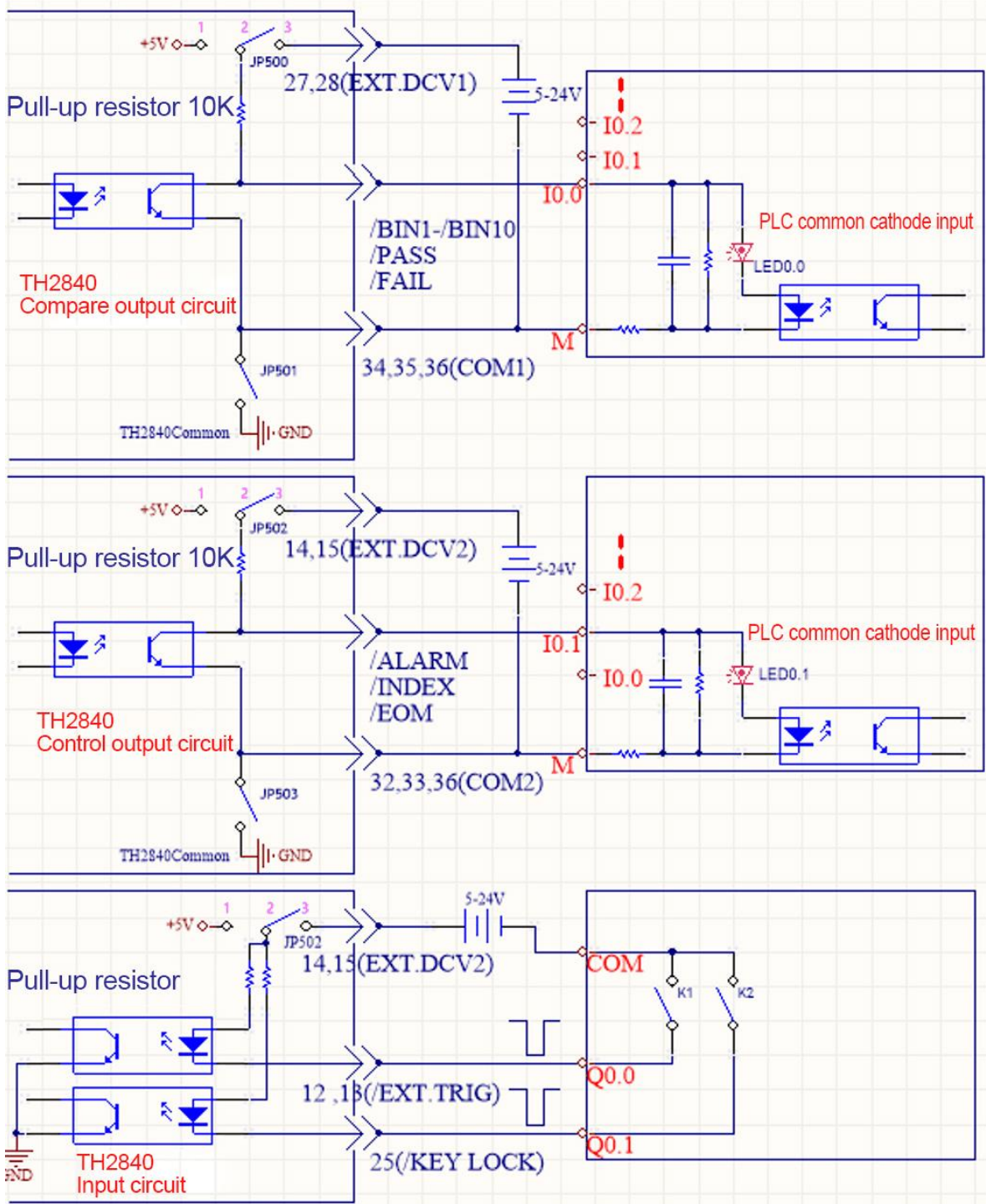

Figure 10-8 PLC wiring diagram where handler interface and input circuit are common cathode

10.1.4 Using Operations

After the HANDLER interface is correctly wired to the PLC, set the limit list to use the comparison function. Then set the HANDLER interface so that it can OUTPUT/INPUT (output / input) signal. The following operation process is the steps of using the comparison function of the HANDLER interface.

Comparison function setting procedure

The following operation steps are the steps of compare functions using the HANDLER interface (only for the functions of the automatic component analyzer)

1. Press the [Setup] key, select <Limit Setup> in the menu on the right side of the display, and enter the limit setup page.
2. Move the cursor to "Comp", select [ON] in the menu area on the right side of the screen, and the compare function will be enabled.
3. Move the cursor to "Count", then select [ON] in the menu area on the right side of the screen, and the count function will be enabled.
4. Move the cursor to "Mode", then select "Tolerance" or "Continuous" in the menu area on the right side of the screen.
5. Set the bin sorting deviation type, reference value, bin limit and related options on the <Limit Setup> page.
6. Press [Display] to enter the <Meas Display> page, and enter the corresponding page to measure the DUT.

Note: The ON/OFF of the comparison function and the ON/OFF of the counting function can also be set in the <Meas Display> page.

10.2 List Sweep Handler Description

When using the list sweep sorting, the interface model provided by the instrument is 57BR-4036L (the same interface as the bin sorting), and provides /FAIL1-/FAIL10 and the total /PASS and /FAIL signals.

10.2.1 List Sweep Sorting Logic

A maximum of 4 parameters can be set for each sweep point. The upper and lower limits of the corresponding parameter settings indicate that they participate in the sorting. If the upper and lower limits are not set, they do not participate in the sorting. All the parameters participating in the sorting among the 4 parameters are qualified, indicating that the sweep point is qualified. As long as there is one unqualified sweep point, the sweep point is judged to be unqualified. In the list sweep display interface, the P/F column at the end of each sweep point will display PASS or FAIL, and the sweep points without upper and lower limits will be displayed at the corresponding P/F. Sweep points 1-10 correspond to /BIN1-/BIN10 in sequence, and all are active low. The sorting results of sweep point 11 and subsequent sweep points do not have separate sorting signals. If all the sweep points with upper and lower limits are qualified, a total PASS signal will be output, and if one of the sweep points with upper and lower limits is set unqualified, a FAIL signal will be output. Sweep points that do not have upper and lower limits set do not participate in the sorting.

10.2.2 Technical Description

10.2.2.1 List Sweep Output Signal

Active low, open collector, optoelectronic isolation

Table 10-5 Output signal

Signal	Overview
/BIN1-/BIN10 PASS, FAIL	Result output
/INDEX	"Analog measurement end" signal
/EOM	"End of all measurements" signal
/ALARM	Provides an alert when a momentary power failure or processor interface board reset is detected.

10.2.2.2 List Sweep Input Signal

The input signal is the same as for bin sorting, see section 10.1.1.2.

10.2.2.3 Signal Line Definition

The list sweep sorting HANDLER interface uses three signals: compare output, control input and control output. The following are the signal definitions of the HANDLER interface when the list sweep sorting function is used.

The signal definition of the list sweep comparison function is different from that of the BIN comparison function. Its definition is as follows:

Compare output signals: /FAIL1 - /FAIL10, PASS, FAIL.

The /FAIL1 - /FAIL10 signal indicates the pass or out-of-tolerance judgment of each sweep point, see Figure 10-9. The /PASS and /FAIL signals are indicated as total judgment signals. These signals will be output when a sweep measurement is completed.

Control output signal: /INDEX (analog measurement completion signal)

/EOM (measurement end and comparison data valid signal)

/ALARM (instrument power down signal).

SEQ sweep mode: The /INDEX signal is asserted valid when the analog measurement of the last sweep point is completed. The /EOM signal is asserted valid after each step of measurement and comparison is completed. The timing diagram is shown in Figure 10-10.

STEP sweep mode: The /INDEX signal is asserted valid after the analog measurement of each sweep point is completed. The /EOM signal is asserted valid after each step of measurement and comparison is completed. The timing diagram is shown in Figure 10-10.

Control input signal: /EXT.TRIG (external trigger signal)

The interface diagram of the above pins is shown in Figure 10-1.

See Table 10-6 for the signal assignment and brief description of the above pins.

The timing diagram is shown in Figure 10-10.

Table 10-6 Pin distribution table of List sweep sorting function

Pin	Signal	Signal direction	Description
1	/FAIL1	Output	Out of the limit of sweep point1
2	/FAIL2		Out of the limit of sweep point2
3	/FAIL3		Out of the limit of sweep point3
4	/FAIL4		Out of the limit of sweep point4
5	/FAIL5		Out of the limit of sweep point5
6	/FAIL6		Out of the limit of sweep point6
7	/FAIL7		Out of the limit of sweep point7
8	/FAIL8		Out of the limit of sweep point8
9	/FAIL9		Out of the limit of sweep point9
10	/FAIL10		Out of the limit of sweep point10
11	Undefined	Output	Factory test, please do not use.
19	/PASS	Output	All points in the measurement result are passed, it is /PASS.
20	/FAIL	Output	As long as one point in the measurement result fails, it is /FAIL.
30	/INDEX	Output	<p>SEQ: The /INDEX signal is valid when the analog measurement of the last sweep point is completed, and the UNKNOWN test terminal of the TH2840 can be connected to the next device under test (DUT). However, the comparison result signal is not valid until /EOM is effective. (See Figure 10-10)</p> <p>STEP: The /INDEX signal is asserted valid after the analog measurement of each sweep point is completed. However, the comparison result signal is not valid until /EOM is effective. (See Figure 10-10)</p>
31	/EOM	Output	<p>End of measurement:</p> <p>Continuous Sweep Mode (SEQ): The /EOM signal is asserted valid after the entire list sweep measurement is completed and all comparisons are valid. (See Figure 10-10)</p> <p>Single step sweep mode (STEP): The /EOM signal is asserted valid after each sweep point measurement is completed and all comparison results are valid. The comparison result signal is valid until the /EOM of the last sweep point is effective (see Figure 10-10).</p>
Other			The definition is the same to that of the comparison. See Table 10-3.

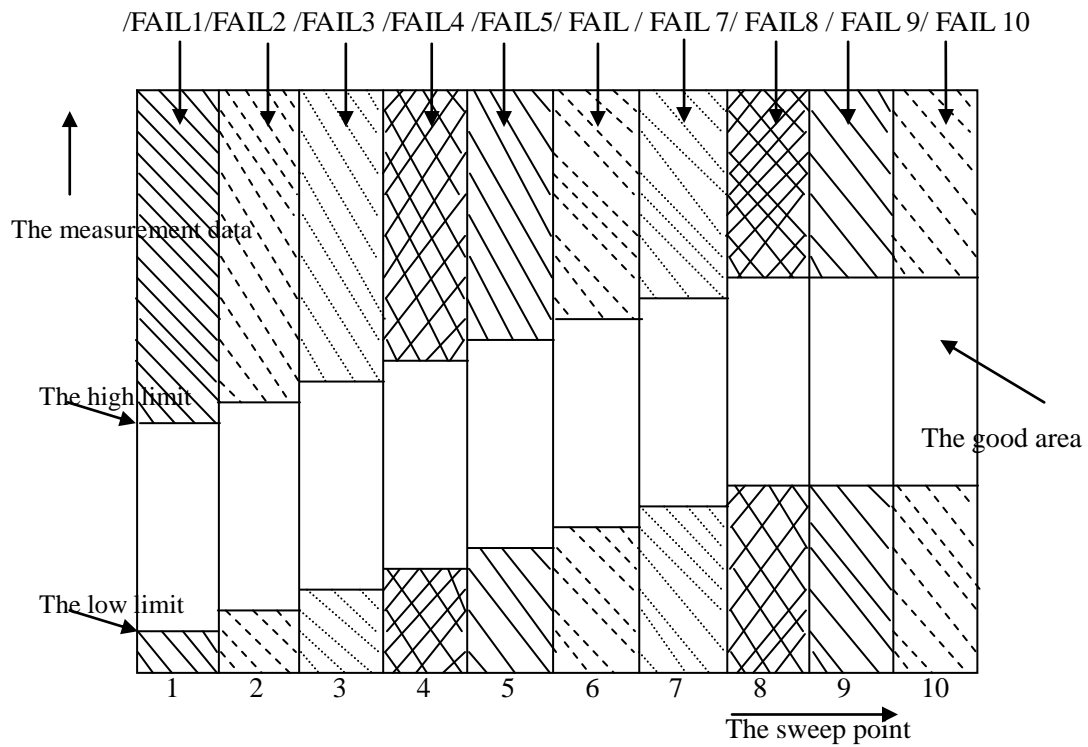
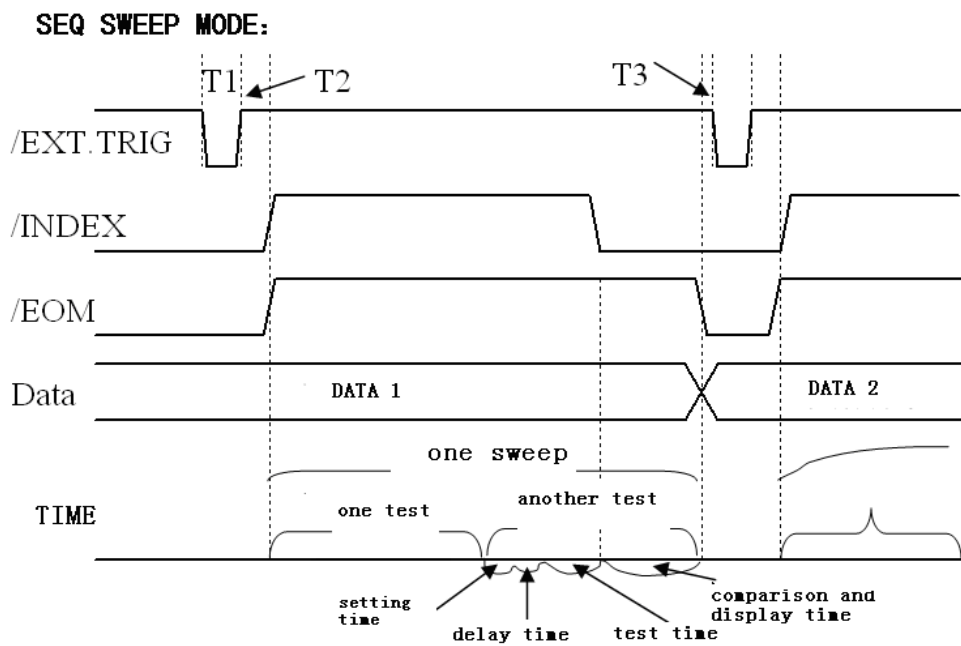

Figure 10-9 The signal area of the list sweep comparison



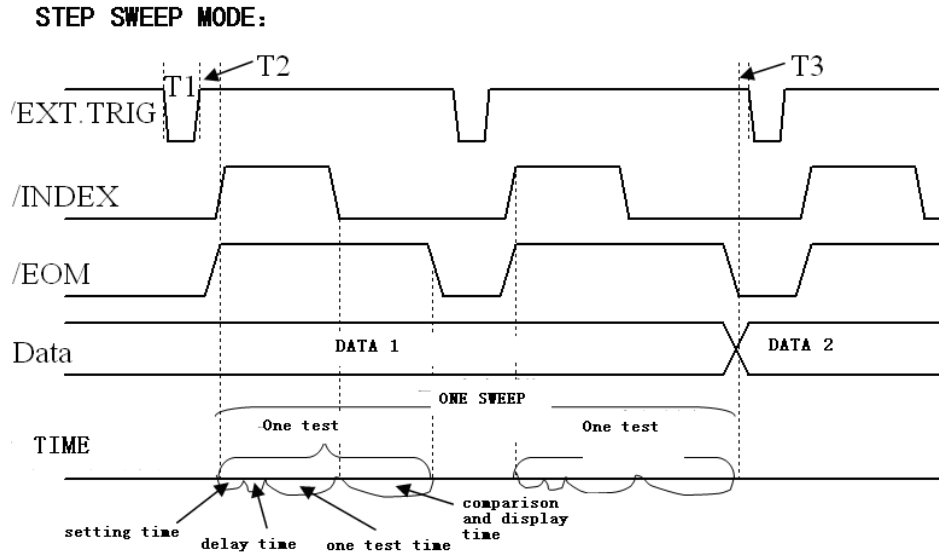

Figure 10-10 the timing chart

Note : (1)The setting time includes the correction ON/OFF time.

(2)The comparison and display time is 4.5ms approximately; T1, T2, T3 See Figure 3.

10.2.3 Electrical Feature

The meanings of some signals in the list sweep comparison function and the bin sorting function are different. However, the electrical characteristics of these signals are the same in both operations, so refer to 10.1.2 for a description of the electrical characteristics of the list sweep sorting function.

10.2.4 List sweep sorting wiring operation instructions

List sweep and bin sorting share the same HANDLER interface in the hardware circuit, and the electrical properties corresponding to the same pin numbers are exactly the same. It is basically the same as the PLC wiring diagram. Therefore, the wiring diagrams refer to 10.1.3.

10.2.5 Using operation

Using the HANDLER interface, set the high and low limits in the list sweep to use the comparison function. Then set the HANDLER interface so that it can OUTPUT/INPUT (output / input) signal. The following operation process is the steps to use the HANDLER interface list sweep compare function.

List sweep compare function setting steps:

1. Press the [Setup] button and click "List Setup" in the menu on the right side of the screen to enter the <List Sweep Setup> page.
2. In the <List Sweep Setup> menu, set the sweep method, sweep frequency point, reference value, upper and lower limits, etc.
3. Press [Display] to enter the <List Display> page. For the description of this page, please refer to the description of the [Display] menu key.

10.3 HANDLER description of transformer single group test

For the sorting of transformer single test, the interface model provided by the instrument is 57BR-4036L, which provides separate sorting of 12 parameters such as /FAIL1-/FAIL12 and the total /PASS and /FAIL signals.

10.3.1 Sorting logic

The sorting signal of the first parameter in the single group setting page corresponds to /FAIL1, the second parameter corresponds to /FAIL2, and so on, the last parameter corresponds to /FAIL12. During the test, which parameter fails the corresponding sorting signal will change. All parameters are qualified, the PASS signal is valid, as long as one parameter is not qualified, the /FAIL signal is valid.

10.3.2 Technical description

10.3.2.1 Output signal

Active low, open collector, optoelectronic isolation

Table 10-7 Output signal

Signal	Overview
/FAIL1-/FAIL12, /PASS, /FAIL	Result output
/INDEX	"Analog measurement end" signal
/EOM	"End of all measurements" signal
/ALARM	Provides an alert when a momentary power failure or processor interface board reset is detected.

10.3.2.2 Input signal

Optoelectronic isolation

Table 10-8 Input signal

Signal	Overview
/KEY_LOCK	Key lock (locks the front panel keyboard, including the touch screen)
/EXT_TRIG	External Trigger: pulsewidth $\geq 1\mu\text{S}$

10.3.2.3 Signal line definition

The HANDLER interface of transformer single test uses three kinds of signals: comparison output, control input and control output. The following is the signal definition of the HANDLER interface when using the transformer single measurement function.

Compare output signal: /FAIL1 - /FAIL12, /PASS, /FAIL.

Control output signal: /INDEX (analog measurement end signal)

/EOM (measurement end and comparison data valid signal)

/ALARM (instrument power down signal).

Control input signal: /EXT.TRIG (external trigger signal)

/Keylock.

See Table 10-9 for the signal assignment and brief description of the above pins.

Table 10-9 The signal assignment of

Pin	Signal	Signal direction	Description
1 2 3 4 5 6 7 8 9 10 11	/FAIL1 / FAIL2 / FAIL3 / FAIL4 / FAIL5 / FAIL6 / FAIL7 / FAIL8 / FAIL9 / FAIL10 / FAIL11	Output	Sorting result All /FAIL (failure signal) outputs are open collector outputs.
12 13	/EXT.TRIG	Input	External trigger: When the trigger mode is set to single, the TH2840 is triggered by the falling edge pulse signal applied to this pin.
14 15	EXT.DCV2	Input	External DC voltage 2: The DC provider pin for the optoelectronic coupling signal(/EXT_TRIG, /KeyLock, /ALARM, /INDEX, /EOM)
16 17 18	+5V	Output	The internal power +5V: to use the internal power is not recommended. If you use the internal power, please ensure that the current is lower than 0.3A and the signal line is far from the disturbance source.
19	/PASS	Output	As long as the measurement result is in any one of /FAIL1-/FAIL12, it will be /PASS
20	/FAIL	Output	If the measurement result is not in any one of /FAIL1-/FAIL12, it will be /FAIL
21	/ FAIL 12	Output	Sorting result of the 12th parameter
22 23 24	Undefined	Output	Factory test signal, please do not connect
25	/KEY LOCK	Input	When this single is effective, all the front

			panel function keys and touch screen of TH2840 are locked and no longer work.
27 28	EXT.DCV1	Input	The external DC voltage 1: the pull-up DC power provider pin for optoelectronic coupling signal (/BIN-/BIN10, /PASS, /FAIL).
29	/ALARM	Output	When circuit is interrupted, /ALARM is effective.
30	/INDEX	Output	When the analog test is finished and the UNKNOWN terminal can be connected to another DUT, /INDEX is effective. But the comparison signal is effective until /EOM is effective.
31	/EOM	Output	End Of Measurement: when the test data and the compared result are effective, this signal is effective.
32,33	COM2	---	The reference ground for external power EXTV2.
34,35,36	COM1	---	The reference ground for external power EXTV1.

10.3.3 Electrical Feature

The definition of some signals in the transformer single measurement sorting function and the bin sorting function and the list sweep sorting function are different, but the electrical properties of the same pin number are exactly the same.

10.3.3.1 DC Isolation Output Signal

Each DC output (pins 1 to 11, 19 to 24, and 29 to 31) is isolated via an open collector optocoupler output. The output voltage of each line is set by a pull-up resistor on the HANDLER interface board. The pull-up resistor is connected with the internal supply voltage (+5V) or with the external supply voltage (EXTV: +5V-24V) by jumper.

The DC isolation output signal utilizes a dedicated electrical system which is independent of the control output signal. Therefore, the processor board has a common line for two separate circuits: COM1 and COM2.

The electrical characteristics of the DC isolated output are divided into two types, see Table 10-10. The output circuit configuration of the test result output signal is shown in Figure 10-3, and the output circuit configuration of the control output signal is shown in Figure 10-4.

Table 10-10 the electrical feature of the DC isolation output

The output signal	The output rated voltage		The maximum current	The reference ground for the circuit
	LOW	HIGH		
Compared signal /FAIL1 - /FAIL12 /PASS /FAIL	≤0.5V	+5V--+24V	6mA	Internal pull-up voltage: TH2840 GND EXTV1: COM1
Control signal /INDEX /EOM /ALARM	≤0.5V	+5V--+24V	5mA	Internal pull-up voltage : TH2840 GND EXTV2: COM2

10.3.3.2 DC Isolation Input Signal

DC isolation input signals include the /EXT_TRIG and /KEY_LOCK signals.

The /EXT_TRIG signal (pin 12 and pin 13) is input to the LED cathode side of the optocoupler. The instrument is triggered when the signal increases from LOW to HIGH. The optocoupler LED (anode side) can be driven by an internal pull-up voltage (+5 V) or an external voltage (EXT.DCV2).

The /KEY_LOCK signal (pin 25) is input to the optocoupler LED (on the cathode side). As long as this is low level, the keys on the front panel of the instrument will all be locked. The optocoupler LED (anode side) can be driven by internal voltage (+5V) or external voltage (EXT.DCV2).

The input circuit configuration of the DC isolation input signal is shown in Figure 10-6.

10.3.4 Handler wiring operation instructions for transformer single measurement

The wiring operation of the HANDLER for single measurement of the transformer is exactly the same as the wiring method of the bin sorting with the same pin number. The wiring diagram of the common anode PLC is shown in Figure 10-7, and the wiring diagram of the common cathode PLC is shown in Figure 10-8.

10.3.5 Using Operation

After the HANDLER interface is correctly connected to the PLC, the deviation mode can be selected in the deviation column on the single group setting page. Deviation mode: Δ , $\Delta\%$. The lower limit of each parameter can be set in the column corresponding to the lower limit, and the upper limit of each parameter can be set in the column corresponding to the upper limit. The first parameter of the single group setting page corresponds to /FAIL1, the second parameter corresponds to /FAIL2, and so on, the twelfth parameter corresponds to /FAIL12. You can select ON in the comparison item on the single group setting page.

The measurement switch of each parameter is selected to be ON, and the upper and lower limits are set at the same time, then the parameter participates in the sorting. Note that this parameter does not participate in sorting without setting upper and lower limits.

10.4 Transformer scan HANDLER description

In Transformer scan, HANDLER uses two DR-25P sockets, namely Trans Handler and Trans Controller. It can provide up to 30 independent sorting signals NS1-NS30, in addition to PASS, NG, TEST and other signals.

10.4.1 Technical Description

10.4.1.1 Output Signal

Active low, open collector, optoelectronic isolation, ULN2003 Drive Enhancement

Table 10-11 Output Signal

Signal	Overview
NS1-NS30, PASS, FAIL	Result output
/TEST	“All measurement end” signal

10.4.1.2 Input Signal

Active low, optoelectronic isolation

Table 10-12 Input Signal

Signal	Overview
EXT_RESET	Reset signal
EXT_START	External trigger signal

10.4.1.3 Signal Line Definition

The HANDLER interface of transformer scan uses three signals: compare output, control input, and control output. The following are the signal definitions of the HANDLER interface when using the transformer scan function.

Compare output signals: NS1–NS30, PASS, FAIL.

Control output signal: TEST (analog measurement completion signal)

Control input signal: EXT_START (external trigger signal)

EXT_RESET (reset signal).

See Table 10-13 (Trans Handler) and Table 10-14 (Trans Controller) for the signal assignment and brief description of the above pins.

Table 10-13 Signal assignment table of transformer scan pins (Trans Handler):

Pin	Signal	Signal direction	Description
1 2 3 4 5 6 7 8 9	NS1 NS 2 NS 3 NS 4 NS 5 NS 6 NS 7 NS 8 NS 9	Output	Sorting signal line: All NS outputs are collector outputs and have different definitions in different sorting modes.
10	TEST	Output	End Of Measurement: when the test data and the compared result are effective, this signal is effective.
11 12 13	+5V	Output	The internal power +5V: to use the internal power is not recommended. If you use the internal power, please ensure that the current is lower than 0.3A and the signal line is far from the disturbance source.
14 15 16 17	GND	Output	
18	24V-	Output	Cathode of cylinder power supply
19	EXT_GND	Input	The reference ground for external power EXT_VCC
20	24V+	Output	Anode of cylinder power supply
21	EXT_VCC	Input	External DC voltage : The DC provider pin for the optoelectronic coupling signal (NS1-NS30,/PASS, /FAIL,TEST)
22	EXT_RESET	Input	Reset signal
23	EXT_START	Input	External trigger signal
24	FAIL	Output	
25	PASS	Output	

Table 10-14 Signal assignment table of transformer scan pin (Trans Controller):

Pin	Signal	Signal direction	Description
1	NS 10	Output	Sorting signal line: All NS outputs are collector outputs and have different definitions in different sorting modes.
2	NS11		
3	NS12		
4	NS13		
5	NS14		
6	NS15		
7	NS16		
8	NS17		
9	NS18		
10	NS19		
11	NS20		
12	NS21		
13	NS22		
14	NS23		
15	NS24		
16	NS25		
17	NS26		
18	NS27		
19	NS28		
20	NS29		
21	NS30		
22	+5V	Output	The internal power +5V: to use the internal power is not recommended. If you use the internal power, please ensure that the current is lower than 0.3A and the signal line is far from the disturbance source.
23			
24	GND	Output	
25			

10.4.2 Electrical Feature

10.4.2.1 DC Isolation Output Signal

Each DC output (pins 1-10, 24, 25 of Trans Handler and pins 1-21 of Trans Controller) are isolated by optocoupler and output from the collector after ULN2003 drive enhancement. The output voltage of each line is related to the power supply voltage used. The high level of the internal power supply is 5V, and the high level of the external power supply is the external power supply voltage. Connect with internal supply voltage (+5V) or with external supply voltage (EXTV: +5V-24V) by jumper. The DC isolated output signal utilizes a dedicated electrical system which is independent of the control output signal. Therefore, a common line for a separate circuit on the processor board:

GND_EXT.

The electrical characteristics of the DC isolated output are divided into two types, see Table 10-14. The output circuit configuration of the test result output signal is shown in Figure 10-11, and the output circuit configuration of the control output signal is shown in Figure 10-12.

Table 10-14 DC isolation output electrical characteristics

The output signal	The output rated voltage		The maximum current	The reference ground for the circuit
	LOW	HIGH		
Compared signal /NS1 - /NS30 /PASS /FAIL	$\leq 0.5V$	+5V--+24V	50mA	Internal pull-up voltage: TH2840 GND External voltage: GND_EXT
Control signal /TEST	$\leq 0.5V$	+5V--+24V	50mA	Internal pull-up voltage : TH2840 GND External voltage: GND_EXT

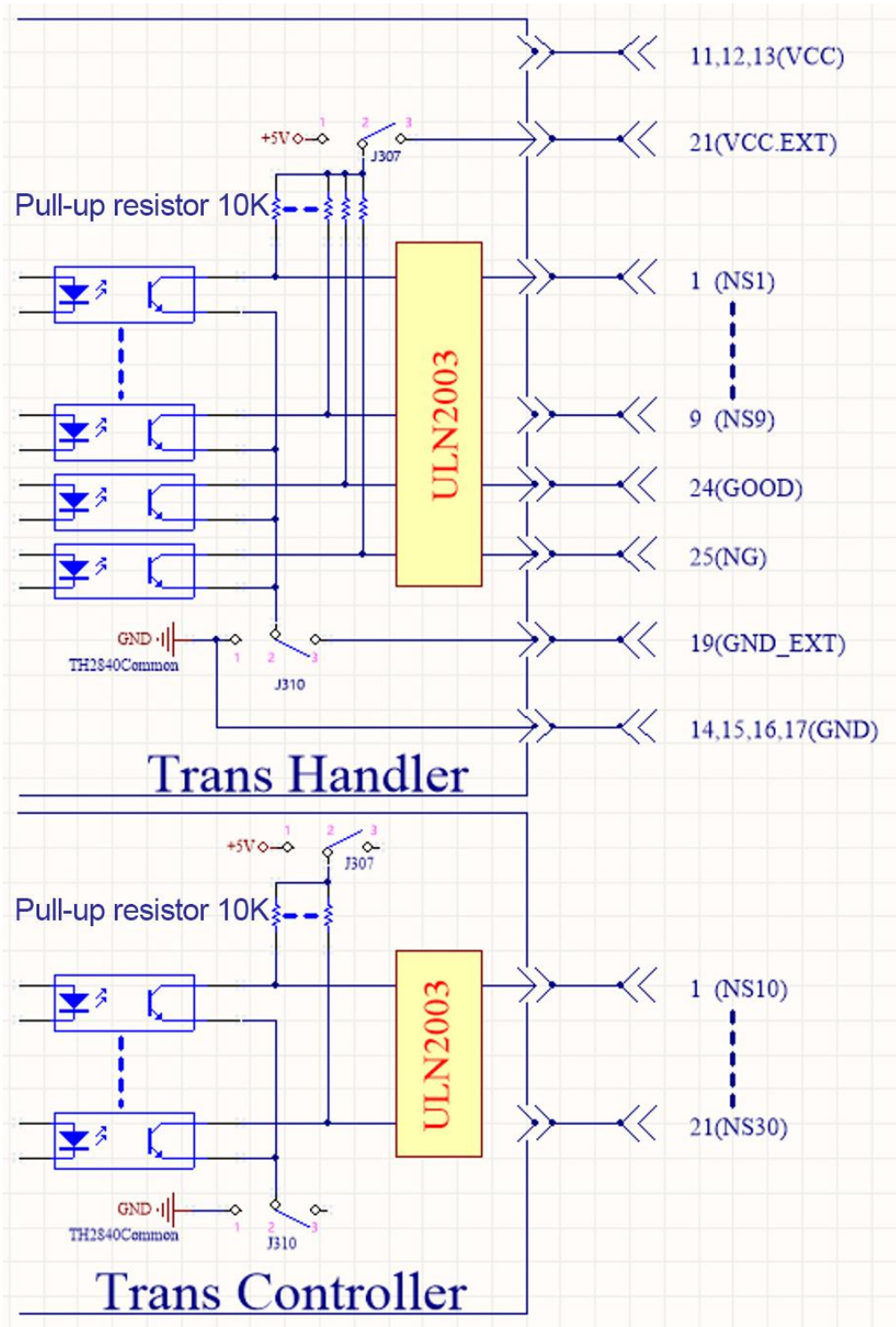

Figure 10-13 Comparison result signal output circuit

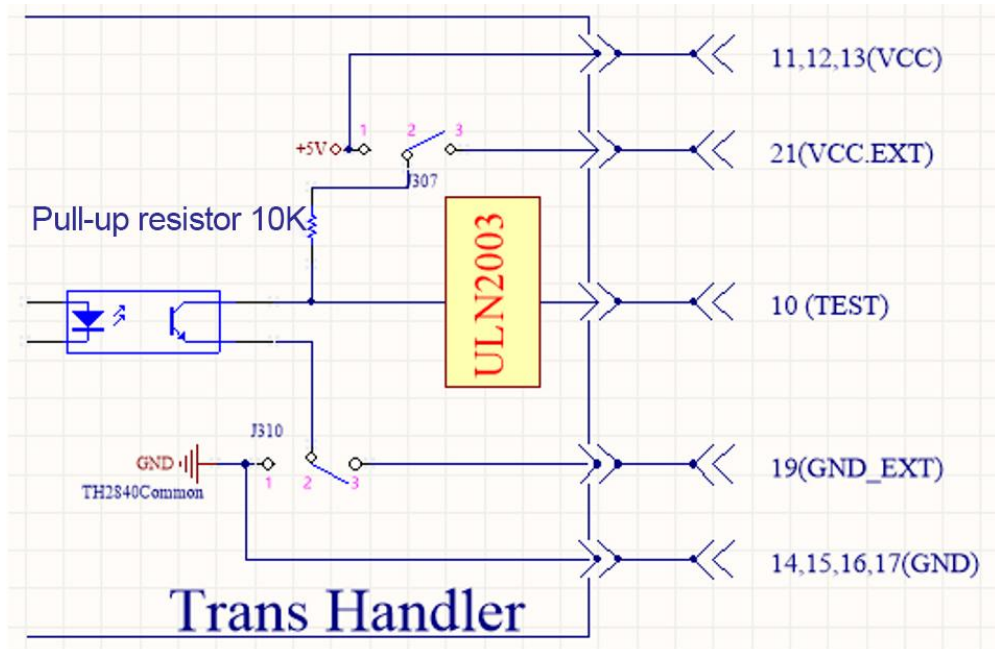

Figure 10-14 Control signal output circuit

10.4.2.2 DC Isolation Input Signal

DC isolation input signals include EXT_RESET and EXT_START signals.

The EXT_RESET signal (pin 22 of the Trans Handler) is input to the optocoupler LED (on the cathode side). As long as this is low level, the keys on the front panel of the instrument will all be locked. The optocoupler LED (anode side) can be driven by internal voltage (+5V) or external voltage (EXT_VCC).

The EXT_START signal (pin 23 of the Trans Handler) is input to the LED cathode side of the optocoupler. The instrument is triggered when the signal increases from LOW to HIGH. The optocoupler LED (anode side) can be driven by an internal pull-up voltage (+5 V) or an external voltage (EXT_VCC).

The input circuit configuration of the DC isolated input signal is shown in Figure 10-15.

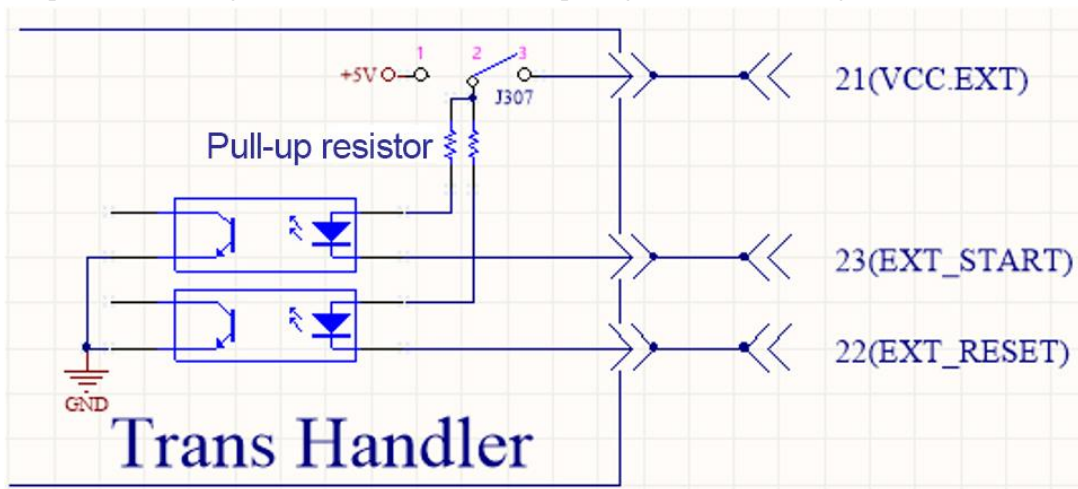

Figure 10-15 Control input circuit

10.4.3 Handler wiring operation instructions for transformer Scan

This section focuses on the example of wiring between the sorting interface of TH2840 transformer scanning and a typical PLC. The wiring example only introduces the wiring of two PLCs, that is, the PLC input circuit common anode and the PLC input circuit common anode. For PLCs with other types of input circuits, you can consult our after-sales service.

The PLC input circuit common anode means that the current flows in from the common terminal of the module and flows out from the input channel of the module, which is often referred to as the source wiring method.

The PLC input circuit common cathode means that the current flows in from the input channel of the module and flows out from the common terminal of the module, which is often referred to as the drain wiring method.

When using transformer scanning and sorting, PLC wiring diagram where handler interface and input circuit are common anode is shown in Figure 10-16, and PLC wiring diagram where handler interface and input circuit are common cathode is shown in Figure 10-17.

The factory default of TH2840 series instrument is external power supply. That is, pins 2 and 3 of J307 are short-circuited, pins 2 and 3 of J310 are short-circuited, JP501 is open, and JP503 is open. Therefore, be sure to connect the power supply to the external power supply pin when using it. If you need to use the internal power supply of the instrument, you need to change the jumper mode of J307 and J310. Please consult our after-sales service for details.

Note: 11, 12, 13 of Trans Handler and 22, 23 of Trans Controller are the 5V power supply inside the instrument and cannot be connected to any external power supply, otherwise the instrument will be damaged.

Considering the anti-interference ability of the instrument, TH2840 recommends users to provide and use an external power supply as the pull-up power supply of ULN2003.

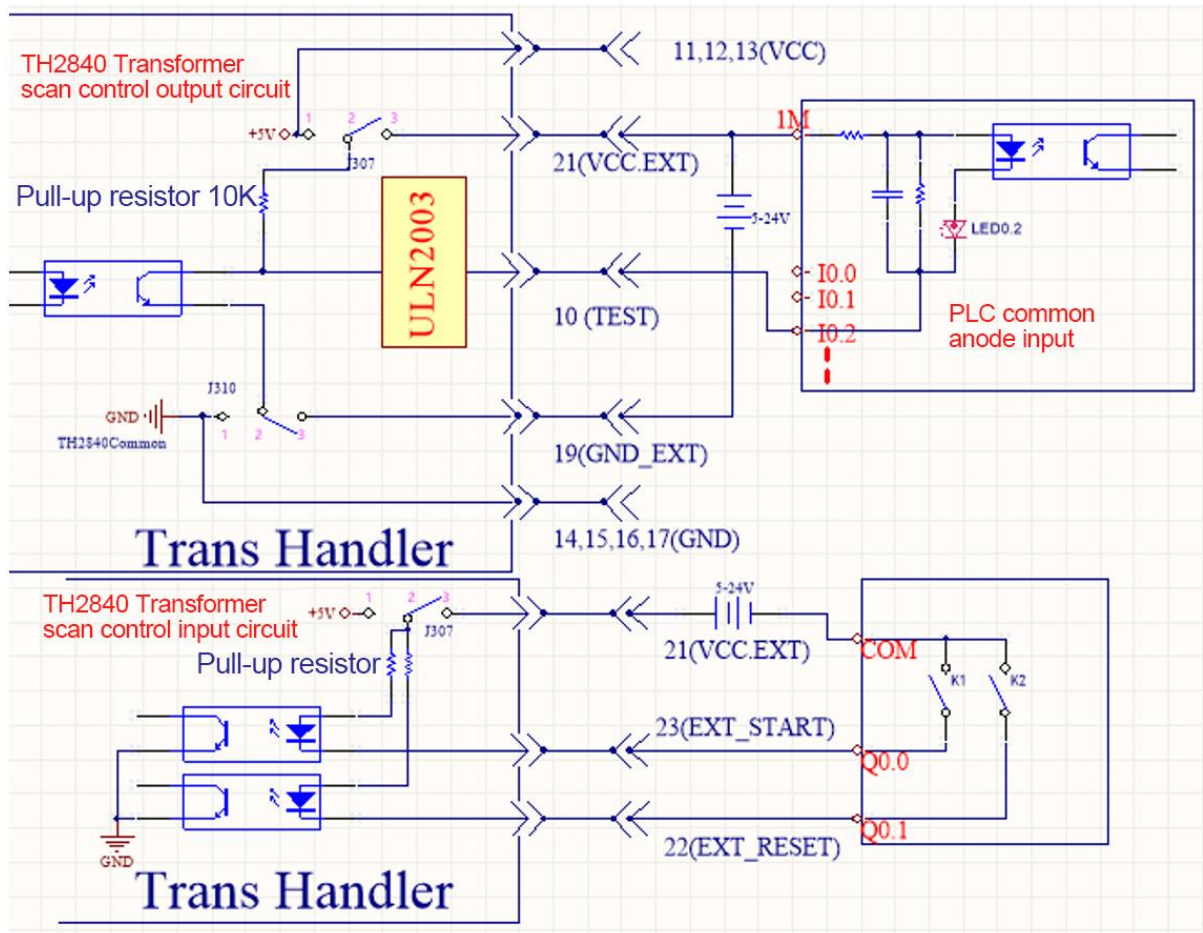

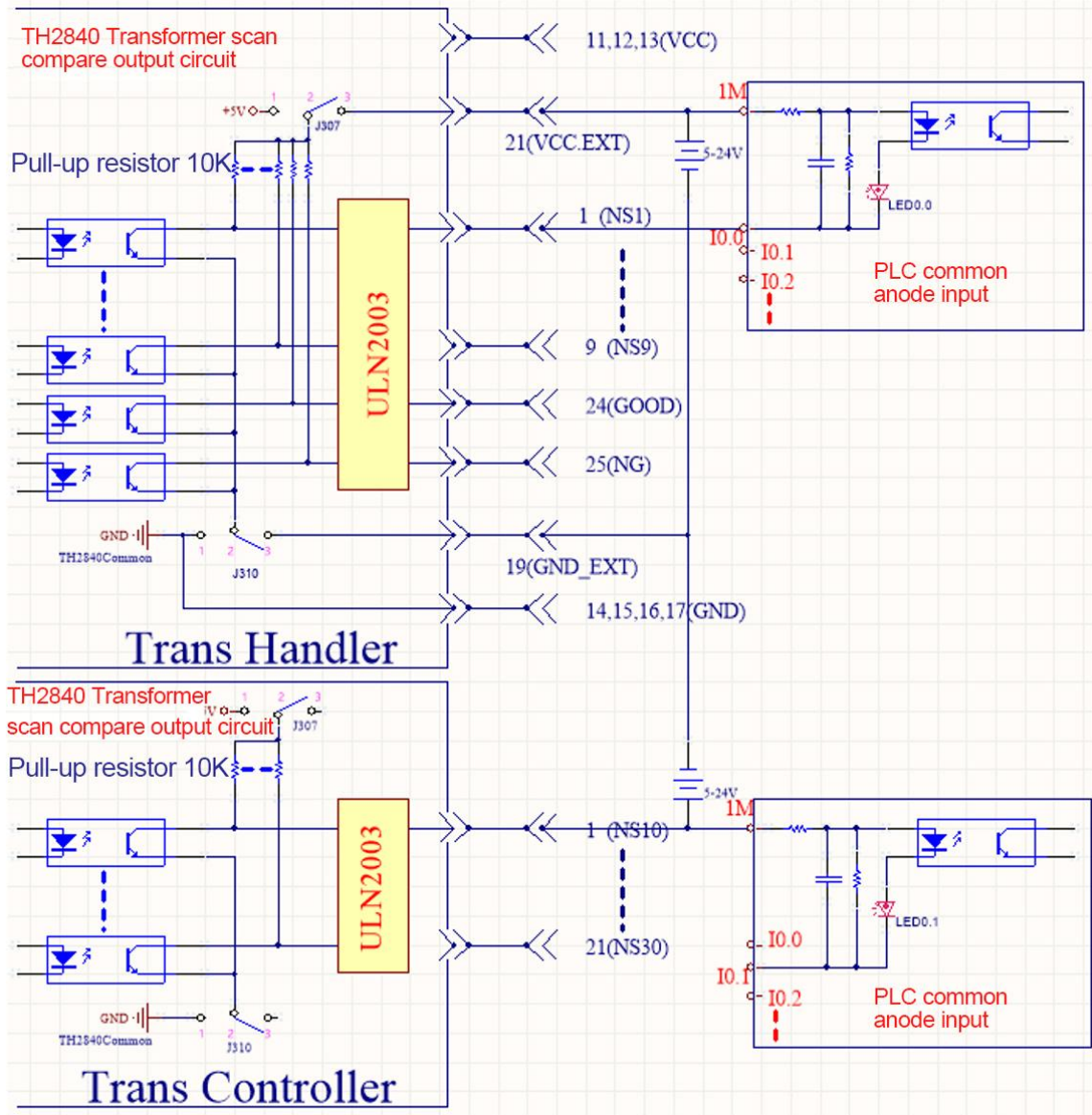

Figure 10-16 PLC wiring diagram where handler interface and input circuit are common anode
 Figure 10-16 Description: The wiring method provided in this figure is a typical connection method, and it needs to be flexibly applied according to the actual situation in practical application.

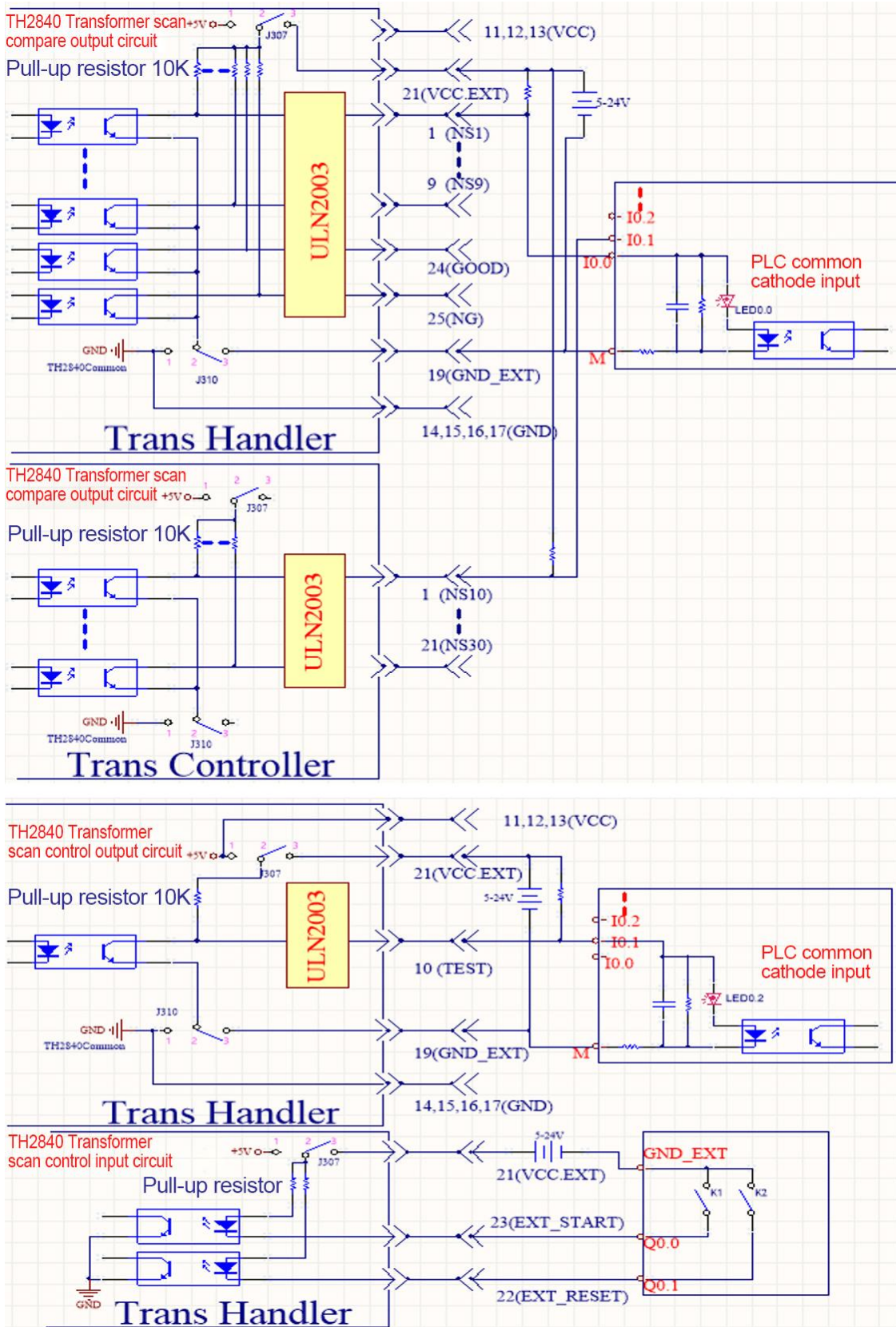

Figure 10-17 PLC wiring diagram where handler interface and input circuit are common cathode

10.4.4 Using operation

Transformer scan sorting is always on. The sorting mode has default, X12, X30.

10.4.4.1 Sorting Mode Setup

After entering the Transformer Scan mode, press "Setup", and click "Handler mode" in the menu bar on the right side of the display screen to enter the handler mode page. There are also pin definitions corresponding to the corresponding handler modes on this page.

10.5 Instructions for HANDLER sorting of scanning fixtures

TH2840AX, TH2840BX, TH2840NX are compatible with TH1901, TH1831, TH1806 series scan boxes.

The TH1831 scan box pin definition is exactly the same as the HANDLER definition of the TH2840 built-in scan board.

Chapter 11 Appendix

11.1 Warranty

The warranty period is two years from the date of shipment of the instrument purchased from the Company by the user unit, and from the date of shipment of the instrument purchased from the operating department. The warranty is issued by the instrument warranty card. During the warranty period, if the instrument is damaged due to improper operation by the user, the maintenance cost is the responsibility of the user. The instrument is responsible for lifelong maintenance by the Company.

It is imperative that the instrument be maintained by professional and technical personnel. It is strictly prohibited for internal components of the instrument to be replaced without authorization. To ensure the accuracy of the test, the instrument must undergo re-measurement of calibration. In the event that the user attempts to perform maintenance without the requisite qualifications, the warranty will be rendered null and void, and the user will be held liable for the costs associated with the maintenance.

It is imperative that the instrument be safeguarded from the detrimental effects of sunlight and humidity. Furthermore, it is of paramount importance that the instrument be utilized in accordance with the specifications delineated in section 1.4.

In the event of an extended period of non-use, it is recommended that the instrument be returned to its original packaging for storage.

Company Statement:

Please note that the contents of this manual may not reflect the complete specifications of the instrument. Tonghui Company reserves the right to make improvements and enhancements to the performance, functions, internal structure, appearance, accessories, and packaging of this product without prior notification. Should you have any questions or concerns regarding the discrepancies between the manual and the instrument, please do not hesitate to contact our company via the address on the cover.