

Operation Manual

TH9130(A)/TH9131(A)

Multi-function Safety Compliance Analyzer

[V1.0.8@2024.03](#)

Tonghui Electronic Co.,Ltd.

www.tonghui.com.cn

Version History:

This manual will be continually improved for ease of use.

Due to possible errors or omissions in the instruction manual, improvement and refinement of the instrument functions, technical updates and software upgrades, the instruction manual will be adjusted and revised accordingly.

Please pay attention to the version of the software you are using and the version of the manual.

March 2024 Eighth Edition

Eighth Edition

March 2024

 **DISCLAIMER:** The Company may make improvements and enhancements to the performance, functions, software, structure, appearance, accessories, packaging, and manuals of this product without notice! If this causes doubt, please contact our company.

CONTENTS

Chapter 1 Overview.....	1
1.1 Introduction.....	1
1.2 Conditions of Use.....	3
1.2.1 Electric Power Source✎	3
1.2.2 Ambient Temperature and Humidity.....	3
1.2.3 Preheating	3
1.2.4 Points of Attention	3
1.3 Volume and Weight	4
1.4 Safety Requirement	4
1.4.1 Electrical Insulation Resistance	4
1.4.2 Dielectric Strength.....	4
1.4.3 Leakage Current.....	5
1.5 Electromagnetic Compatibility.....	5
Chapter 2 Operational Norms and Measures	6
2.1 Operational Specification	6
2.2 Treatment Measures	8
Chapter 3 Panel Description and Operating Instructions.....	11
3.1 Front Panel Description.....	11
3.2 Rear Panel Description	12
3.3 Overview of the Instrument Interface Structure	14
3.4 System Parameter SYSTEM Setting	14
3.4.1 System Test Parameter Setting.....	14
3.4.2 System Environment Parameter Setting.....	20
3.4.3 System Communication Settings	21
3.5 Measurement Setting SETUP Setting.....	22
3.5.1 AC Withstand Voltage Test Setup	23
3.5.2 DC Withstand Voltage Test Setup.....	26
3.5.3 Insulation Resistance Test Setup.....	29
3.5.4 Ground Resistance Test Setup	31
3.5.5 Conductivity Test Setup.....	33
3.5.6 Electrical Test Setup (only available for TH9130/TH9131)	35
3.5.7 Leakage Current Test Setup (only available for TH9130/TH9131).....	37
3.5.8 Open Short Circuit Test Setup.....	50
3.6 Measurement TEST Setting.....	51
3.6.1 Zero	54
3.6.2 List Display and Step Display.....	54
3.7 How to Test.....	55
3.7.1 Offset Clearing of Test Leads/Fixtures.....	55
3.7.2 Sampling Operation of Standard Capacitors	55
3.7.3 DUT Connection Method.....	56
3.7.4 Test Program	57
3.8 File Storage	59
3.9 HANDLER	60
3.9.1 Brief Description of HANDLER.....	60

3.9.2	External Control Line Legend.....	64
Chapter 4	Interfaces and Communications.....	67
4.1	Remote Control Interface.....	67
4.1.1	RS232C Interface Description.....	67
4.1.2	GPIB Interface Description.....	74
4.2	Serial Port Command Set Description.....	78
4.2.1	SCPI Instruction Set.....	81
4.2.2	DISPlay Subsystem Command Set.....	81
4.2.3	FUNcTion subsystem Command set.....	83
4.2.4	SYSTem Subsystem Command Set.....	120
4.2.5	MMEM Subsystem Command Set.....	126
4.2.6	USB Subsystem Command Set.....	128
4.2.7	FETCh Subsystem Command Set.....	131
4.2.8	Other Control Command Sets.....	132
Chapter 5	Technical Indicators.....	134
Chapter 6	Appendice.....	144
6.1	Warranty.....	144
6.2	Manual Change Instructions.....	144

Chapter 1 Overview

Thank you for purchasing and using our products, before you use this instrument, first of all, please confirm according to the last chapter of the manual "Warranty", if there is any discrepancy, please contact us as soon as possible in order to safeguard your rights and interests.

1.1 Introduction

Model TH9130(A)/TH9131(A) Multi-function Safety Compliance Analyzer is designed for full performance safety testing of electronic and electrical equipment. Including AC and DC withstand voltage, insulation resistance, grounding resistance, conduction test, electrical performance and leakage current and other safety test functions. In terms of withstand voltage test, the output power AC: 500VA (5kV, 100mA), DC: 120VA (6V, 20mA), so it can be used for high-power electrical appliances, motors and other equipment to do the withstand voltage test, but also can do the same test for parts. In the insulation resistance test, the display range is 0.05M Ω ~ 50G Ω , test voltage 50V ~ 6000V can be set arbitrarily. In the grounding resistance test current can be up to 40A, and the test voltage can be set. It can also be carried out at the same time with the voltage test, greatly reducing the test time, improve test efficiency. Electrical performance test can detect 277V/16A maximum 4500W of high-power equipment operating conditions. The instrument supports a variety of human body impedance simulation circuit MD, through the eight kinds of DUT power state to detect the leakage current to ground, surface to ground leakage current and leakage current between surfaces.

The instrument is equipped with a 7-inch touch screen, which both displays all test modes, time, voltage, current, resistance values, test steps, etc. on the screen, and allows direct control operation of the instrument. There is also a list display mode, which shows multi-step settings and sequential test results. The instrument is equipped with RS-232C, USB, HANDLER, and optional GPIB suitable for the test system, making the instrument adaptable to a variety of different needs for high security and reliability of the Automatic test system.

The instrument offers a wide range of test functions, typically.

■ AC/DC Withstanding Voltage Test:

Instrument output power

TH9130/TH9130A: AC: 500VA (5kV, 100mA), current up to 120mA when AC voltage is less than 4kV; DC: 150VA (6kV, 25mA), current up to 20mA when DC voltage is more than 1.5kV.

TH9131/TH9131A: AC: 200VA (5kV, 40mA); DC: 120VA (6kV, 20mA).

■ Insulation Resistance Test:

The test range is 0.05M Ω to 50G Ω , and the test voltage is 50V to 6000V, which can be set arbitrarily in 1V steps.

■ AC Grounding Resistance Test:

Test current range 1-40A, test voltage adjustable 3-8V, can measure 0-600m Ω grounding resistance, another can be carried out at the same time with the withstand voltage test, to improve test efficiency.

■ Conductivity Test:

Test range 0-10k Ω , can test whether the ground wire is connected reliably, and can test whether the L&N is shorted abnormally to avoid the danger of powering up. It can also test the condition of grounding wire connection at the same time of voltage resistance test.

■ Electrical Test (only available for TH9130/TH9131):

Test range 0-277VAC, max 16A, power max 4500W.

■ Leak Test (only available for TH9130/TH9131):

The three switches can simulate eight DUT power states, provide multiple sets of human impedance simulation network MD, and can perform leakage current to ground, surface-to-ground leakage current, and surface-to-surface leakage current testing. The test current can be selected as peak or RMS; and AC, DC or AC+DC composite wave can be tested.

■ 500VA AC Power Supply (only available for TH9130)

The instrument has a built-in 500VA AC power supply, which can provide power for electrical testing and leakage testing of DUTs, and also supports the use of external power supply to access the instrument for testing.

■ Open Short Circuit Detection OSC.

Before high-voltage testing, determine whether the parts under test are reliably connected to reduce the occurrence of poor contact.

■ ARC Detection Function.

High frequency signal detection is used to determine whether the insulation of the measured part is defective or not.

■ Crash Voltage Test Function:

According to the setting, the measured parts are gradually measured to detect the degree of high-pressure tolerance in order to analyze the improvement.

■ List Display Function: Simultaneous display of multi-step setups and test results executed in sequence.

The instrument provides a variety of convenient communication interfaces to facilitate the output of measurement results to external devices (e.g., computers) or to form an automated test system.

▲ RS-232C interface: RS-232C provides great convenience for serial communication between the instrument and peripheral devices, through which peripheral devices can set various functions and parameters of the instrument.

▲ USB DEVICE port and LAN port.

▲ HANDLER INTERFACE: This interface allows the instrument to be connected to automation equipment to control the instrument and provide feedback on test results.

▲ GPIB interface (option): This universal interface provides a convenient way to combine the instrument with computers and other measuring instruments to form an automated

test system.

The instrument also provides a convenient and practical file function to save the measurement parameters set by the user. Up to 100 files can be saved, each with up to 50 steps.

1.2 Conditions of Use

1.2.1 Electric Power Source

Power supply voltage: 100V~240VAC

Power supply frequency: 47Hz~63Hz

Rated power: 1200W

1.2.2 Ambient Temperature and Humidity

Normal operating temperature: 0°C~40°C, Humidity: 20%~90%RH

Reference operating temperature: 20°C±8°C, humidity: < 80%RH

Storage ambient temperature:-10°C~55°C, humidity:< 90%RH

1.2.3 Preheating

Warm-up time after power on: ≥ 20 minutes

1.2.4 Points of Attention

(1) Please do not use it in adverse environment such as dusty, vibration, direct sunlight, corrosive or flammable gas.

(2) When the instrument is not used for a long time, please store it in the original packing box or similar box in a dry and ventilated room with suitable temperature, the air should not contain harmful impurities that corrode the measuring instrument, and it should be protected from direct sunlight.

(3) Before starting the power supply, make sure that the supply voltage and fuses are the same as those in the unit's instruction manual, including shape, rating, and characteristics. If a different type of fuse is used or if there is a short circuit, then the unit may be damaged.

Input Voltage Range	Frequency Range	Fuse (Slow Fuse)	Rated Power
110VAC (100V to 120VAC)	47-63 Hz	0A	200VA
220V (200V~240VAC)		0A	200VA

(4) This instrument has been carefully designed to minimize spurious interference due to inputs from the AC power supply side, however, it should still be used in as low a spurious environment as possible, and if this cannot be avoided, a power supply filter should be installed.

(5) Do not use the instrument in areas with strong magnetic or electric field effects, as electromagnetic pulses can cause the instrument to malfunction and possibly create a fire.

(6) Do not use this instrument near sensitive test equipment and receiving equipment. If this instrument is used in the vicinity of such equipment, noise from failure breakdown of the part under test may affect such equipment. Above a test voltage of 3 kV, the electric field between the test leads can ionize the air and create a corona, which generates a large amount of RF (Radio Frequency) bandwidth interference between the test leads. To minimize this effect, make sure the test leads are far enough apart. In addition, keep the test leads away from conductive surfaces (especially sharp metal ends).

(7) There is a cooling fan at the back of the instrument and cooling vents on the left and right to avoid the internal temperature from rising and affecting the accuracy, please make sure the instrument is in a well-ventilated condition.

(8) Do not switch the instrument on and off frequently. After disconnecting the power switch, make sure that there is an interval of a few seconds or more before turning the power switch on again. Do not repeatedly turn the power switch on/off, as the instrument's protection may not be fully operational if this is done. Do not turn off the power switch while the instrument is generating test voltage, except in special or emergency situations.

(9) When normal use of the instrument, as far as possible to make the function of interlock (INTERLOCK) to ensure the safety of use. Working space is more confined occasions: for the test piece to make a box-like structure; in the complex structure of the large test piece for testing occasions: in the test area around the use of fences and so on to prevent electrocution protection structure, in the electrocution protection structure is opened, disconnect (INTERLOCK) signal circuit, to ensure that the workplace is safe and reliable.

1.3 Volume and Weight

Volume: 430mm(W)*132mm(H)*550mm(D)

Weight: 40kg

1.4 Safety Requirement

This instrument is a Class I safety instrument

1.4.1 Electrical Insulation Resistance

The insulation resistance between the power supply terminals and the housing is not less than 50M Ω under reference operating conditions.

Insulation resistance between the power supply terminals and the housing under hot and humid transportation conditions is not less than 2M Ω ;

1.4.2 Dielectric Strength

Under the reference working conditions, the power supply terminals and the shell can withstand the rated voltage of 1.5kV, frequency of 50Hz AC voltage for 1 minute, without breakdown and flying arc phenomenon.

1.4.3 Leakage Current

Leakage current is not more than 3.5mA.

1.5 Electromagnetic Compatibility

Power transient sensitivity according to GB6833.4.

Conductivity sensitivity is according to the requirements of GB6833.6.

Radiation interference according to the requirements of GB6833.10.

Chapter 2 Operational Norms and Measures

This chapter describes the norms and measures to be observed during the use of this instrument. When using this instrument, special care should be taken to ensure safety.

WARNING: This instrument has a test high voltage output of 5kVAC or 6kVDC, and incorrect or faulty operation of this instrument may result in an accident or even death! Therefore, for your own safety, please read the precautions in this section and memorize them to avoid accidents.

2.1 Operational Specification

1) Insulated gloves

Wearing insulated gloves when using the instrument will protect you from touching the high voltage but try not to touch a live conductor with your hands during a high voltage test.

2) Grounding

There is a safety ground terminal on the rear panel housing of this tester, please connect this ground terminal to electrical ground (safety ground, earth ground) with appropriate tools. Without good grounding, when the circuit of the power supply is shorted to ground or the connecting wires of any equipment are shorted to ground, high voltage may be present in the housing of the tester, which is very dangerous and may result in an electric shock accident whenever anyone touches the housing of the tester in the above condition. Therefore, make sure that the safety ground terminal is connected to earth.

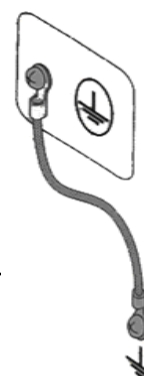

3) Test lead connection

Press the [STOP] key first to confirm that the DANGER indicator is not lit, and then test the wire line connection.

When connecting a test lead to the DUT, first connect the test lead at the RETURN end to the DUT. It is very dangerous if the test lead at the return end is not fully connected or if it is dropped, because the whole DUT may be filled with high voltage.

The high voltage plug of the high voltage test lead must be locked by turning it 90 degrees clockwise after inserting it into the HV to prevent the test lead from falling out.

Before testing, you must check that the test wires on the HV or Return side are not connected, loose or disconnected.

4) Suspension (pause) of testing

To change the test conditions, first press the STOP switch once to take the instrument out of test readiness and make sure that the DANGER lamp is not illuminated. If you need to take a break for a while or will be leaving the place where the test is being conducted, turn off the power switch to prevent a safety hazard caused by accidentally touching the start switch.

5) Remote control

Special care should be taken when using the instrument in remote control mode, as the start

and stop of the high voltage is controlled remotely and the operator cannot know the actual working status of the instrument through the interface. **Pay particular attention to the reliability of the remote-control connection.**

- The "STOP" button must be connected reliably. Press the "STOP" button before replacing the part under test.
- When working in a crowded work environment, the remote switch must have an "INTLOCK" interlock switch and a high voltage indicator. Disconnect the "INTLOCK" interlock switch before replacing the DUT.
- Do not allow the operator or other personnel to touch the DUT, test leads, probes, outputs, and their surroundings while testing the voltage output.

6) Test completion confirmation

If you have to touch a high-voltage area such as the DUT, test leads, probes, or outputs due to reconnection or other test-related conditions, make sure that.

- The power switch is turned off or the instrument displays an operating status other than test status and the DANGER lamp goes out.
- The DUT may be filled with a high voltage at the end of the test, and special attention should be paid to whether the DUT is fully discharged.

7) High voltage test discharge

In a high voltage test, the test leads, test probes and the part under test are charged with high voltage. The instrument has a discharge circuit, which is sometimes required even after the output has been cut off. There is still a risk of electric shock during the discharge process, so do not touch anything that could cause an electric shock. At the end of the test, the instrument's discharge circuitry begins to force a discharge. Do not disassemble the DUT during the test or until the discharge is complete.

Discharge Time: ☺

The time for the voltage to be fully discharged is determined by the test voltage used and the characteristics of the part under test itself.

In the test process, the component under test is discharged through the transformer side (about 2k resistance) to realize the 10uF capacitor 6000V voltage discharge to 30V time of about 0.1s. Instrument fixed discharge time of 0.2s can ensure that the discharge is complete. Instrument internal filter capacitor is discharged through the discharge circuit, can ensure that 0.2s discharge completely.

Assuming that a high voltage applied to the DUT is equivalent to a high voltage applied to a circuit with a 0.01uF capacitor connected in parallel with a 100MΩ resistor, if the DUT is separated during the test or before the end of the discharge, and the DUT is discharged to a voltage of 30V, the test voltage will take about 5s for a test voltage of 5,000V, and about 3.5s for a test voltage of 1,000V.

Discharge time calculation formula: $t = -\ln(30 / U) \times R \times C$

t: Discharge time

30: Discharge residual safety voltage 30V

U: Test set voltage

R: Discharge impedance of the measured part, about $2k\Omega$ resistance

C: Capacitance of the measured part

If the time constant of the part under test is known, then the time required to discharge to 30V after the output is cut off can be derived from the above equation.

8) Turn the power switch on or off

Once the power switch is cut off, if you want to turn it on again, wait for a few seconds and do not turn the power switch on and off continuously to avoid erroneous operation. Especially when there is a high-voltage output state, it is very dangerous to turn on and off continuously. **When turning on or off the power supply, the high voltage output terminal must not be connected to any objects to avoid danger caused by abnormal high voltage output.**

9) Do not touch the high voltage area during testing

Do not approach or touch the areas around the high-voltage outputs, high-voltage test leads, high-voltage probes, parts under test, and their exposed conductors that carry dangerous high voltage while the instrument is under test.

WARNING: Never touch the alligator clips on the test line. It is very dangerous to touch the alligator clips when the instrument is under test because the rubber skin on the alligator clips is not insulated enough!

10) Do not short the test output to ground

Do not short-circuit the instrument's HV output, ground wire to the transmission line or other connector's ground wire, or to the AC power supply to avoid charging the entire tester's enclosure to a very dangerous voltage. To short-circuit the HV output HV to the Return terminal, the entire enclosure of the tester must first be securely connected to earth.

11) Do not connect external voltage to the test terminal

Do not connect any external voltage to the output of the instrument. In the non-discharged state, the instrument is not capable of discharging externally, and connecting the outputs to external voltages may damage the instrument.

2.2 Treatment Measures

1) Handling of emergencies

In case of emergency (e.g. electric shock and burning of the measured part) the instrument is not disconnected from the high voltage output, do the following. You can do either (a) or (b) first, but both operations must be done.

- (a) Turn off the instrument's power switch.
- (b) Unplug the instrument's power cord from the power cord plug.

2) Hazardous condition handling of faulty instruments

In the following cases, the problems that occur are very dangerous, and even if the [STOP] key is pressed, high voltage may still be output from its outputs therefore great care must be

taken.

- When the [STOP] key is pressed, the DANGER indicator remains on continuously.
- The voltmeter has no voltage reading, but the DANGER indicator is on.

When the above condition occurs, please turn off the power immediately and unplug the power supply. Keep away from the instrument immediately and ask the relevant technician to test the test circuit to confirm that there is no danger; or leave the instrument for more than one hour to confirm that there is no output voltage at the test terminal. Remove the relevant connecting wires and send the instrument back to us for repair.

WARNING: Keep away from this instrument immediately after turning off the power and prevent other persons from approaching, and never disassemble the test circuit immediately. Contact our distributor or dealer immediately. High voltages may remain inside the instrument, and it is very dangerous for non-professionals to attempt to troubleshoot the instrument!

3) **DANGER indicator failure**

When it is found that there is already a reading on the voltmeter after pressing the [START] key, but the DANGER indicator is still not on, it may be that the indicator is faulty, so please turn off the machine immediately and send the instrument back to our company or office for maintenance treatment.

4) **Trouble-free use for long periods of time**

If the upper limit set is limited to 100.0mA (during the withstand voltage test), please pay attention to its temperature change, and if the surrounding temperature exceeds 40° C first suspend use and wait for the temperature to drop to the normal temperature before using it, and be sure to test it.

5) **Replacement of fuses**

To prevent electric shock, make sure the power switch is turned off and the AC power cord is unplugged before checking or replacing the fuse. Remove the fuse holder located in the electrical outlet, remove the fuse and press the new fuse into the holder before pressing it into the electrical outlet.

WARNING: Ensure that the fuse used is the same as the one in the device's instruction manual, including shape, rating, and characteristics. If a different type of fuse is used or a short circuit is made, then the unit may be damaged.

6) **AC adapter**

The AC input power used for this instrument is 100V~240VAC and the frequency is 47Hz~63Hz. If the power supply is very unstable, it will cause the instrument to operate incorrectly or abnormally, so please use appropriate equipment to switch to the applicable power supply, such as a power regulator.

7) Instrument output power 500VA

If the device under test draws a large amount of current, a large current (about tens of amperes) may flow for tens of milliseconds before the defective product is judged and the output current is cut off, and the same may happen before the test is conducted. Therefore, it is necessary to pay attention to the capacity of the power supply line and the applicable current line for common connection with other instruments or equipment.

8) Test Leads Away from Panel

When operating the equipment, keep the high voltage line or the object to be measured at least 30CM away from the panel to avoid interfering with the display.

9) Precautions for connecting automation equipment

- The equipment must be connected to the grounding system of the automation equipment.
- The 2 ends of the high voltage line and the Return test line (the output of the device and the end of the object to be tested) are fitted with anti-interference magnetic loops, and the wire is wound at least one turn or more.
- The High Voltage and Return test wires must be separated from the control wires.
- The High Voltage and Return test leads must be kept at an appropriate distance from the instrument/panel.

Chapter 3 Panel Description and Operating Instructions

This chapter contains descriptions and introductions of panels and operations.

3.1 Front Panel Description

The front panel schematic is shown in Figure 3-1.



Figure 3-1

1	Power switch (POWER) ⚡	Turns AC power on or off. When in the pressed position, power is on; when in the ejected position, power is off.
2	START key (green side) STOP key (red circle)	START key: Used to start the test, once the test starts the DANGER indicator lights up. STOP key: Stop key is used to abort the test; it can also be used to cancel the prompt status of PASS, FAIL, etc.
3	USB port	Used to connect an external USB memory.
4	Instrument Trademarks and Models	
5	PrtScn key	Screenshot button to capture the current screen image to USB memory, the memory must be pre-plugged into the front panel socket.
6	F1 to F6 selection keys	There are different functions under each different display screen. There are corresponding function options on the right side of the display screen for quick selection. If the description text is blank or in gray font, it means that the corresponding key is invalid.
7	FILE key	File shortcuts to view internal files as well as external files.
8	Functional area (FUNCTION)	TEST key, press the key lights up, the instrument enters the ready-to-test state. SETUP key, press the key lights up, the instrument enters the parameter setting interface. SYSTEM key, press the key lamp lights to display the system setting interface.

9	Arrow key	Used to move the cursor around the screen, the selected parameter is displayed with an orange background.
10	Numeric keypad	Used to enter numbers or, if required, characters (file names).
11	Indicator light area	PASS lamp, after the end of the test, no test data beyond the initial setting is found, the instrument judges that the test is qualified, and the PASS judgment lamp is on. FAIL lamp, in the test, appear beyond the set test data, the instrument judgment test failed, FAIL judgment lamp on. DANGER light, this light will be on as long as the test is in progress, indicating that the test is in progress. Indicates that high voltage is being output.
12	HV side	High potential terminal for high voltage output, this terminal is a high voltage output terminal and should not be touched when the DANGER light is on with high voltage output.
13	Return side	High-voltage test reference, also known as the low-potential terminal
14	Ground resistance test terminal	The four test terminals for ground resistance include the Current output Current terminal, the Current return Return terminal, and the Sense+ and Sense- terminals for voltage sampling.
15	Liquid crystal display (touch screen)	Display of test information, operation settings
Table 3-1		

3.2 Rear Panel Description

The rear panel schematic is shown in Figure 3-2.

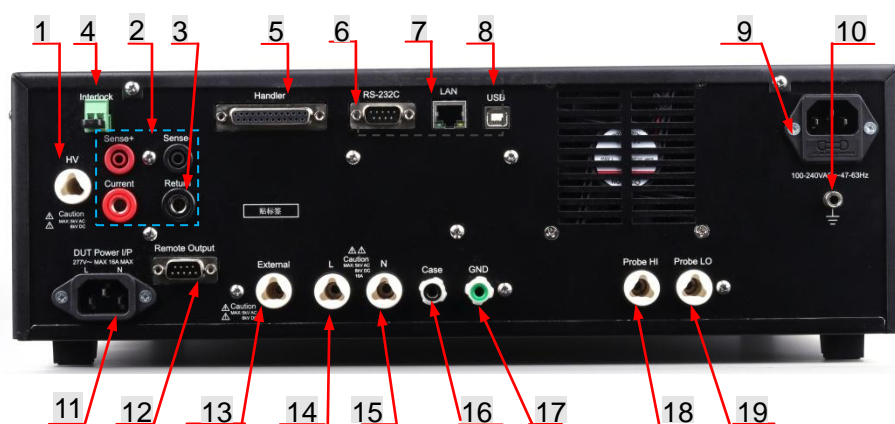

Figure 3-2

1	HV side	High potential terminal for high voltage output, this terminal is a high voltage output terminal and should not be touched when the DANGER light is on with high voltage output.
2	Ground resistance test terminal	The four test terminals for ground resistance include the Current output Current terminal, the Current return Return terminal, and the Sense+ and Sense- terminals for voltage sampling.
3	Return side	The high-voltage test reference, also known as the low-potential terminal.
4	INTER LOCK	Short-circuit these terminals to allow high voltage output.
5	HANDLER interface	This interface allows control of instrument start/stop and output of test results. See the Instrument HANDLER Interface Description section for a detailed description.
6	RS232C interface	Serial communication interface to communicate with a computer.
7	LAN interface	Communication interface to communicate with a computer.
8	USB DEVICE interface	A communication interface through which a computer can control the instrument with a set of control Commands.
9	Electric socket	AC power outlet and fuse holder for a three-wire power and fuse outlet.
10	Protective earth terminal	Safety ground terminal, need to use the appropriate tools, this grounds terminal reliable ground.
11*	Power input for object to be measured	The input of the DUT's operating power supply is also the input of the external AC source.
12*	Remote output terminal	Connect the external AC power supply and control the sequence of the AC power supply to make its output.
13*	EXTERNAL end	For voltage or insulation resistance testing, the DUT can have one additional external test point.
14*	L-line output	Connect to the Firewire output terminal of the DUT.
15*	N-wire output	Connect to the zero-line output terminal of the DUT.
16*	Case end	A terminal for connecting the enclosure or grounding point of the DUT to this instrument. This grounding point is completely isolated from the leakage current test circuit during the leakage current test.
17*	GND terminal	The ground wire of the input power supply of the DUT is connected to the connection terminal of this instrument, and this terminal is completely isolated from the ground terminal (10 in the figure) on this instrument.
18*	Probe HI side	The high voltage input to the human body impedance analog circuit (MD) test bar is typically the high voltage input to the surface leakage current test and the surface-to-surface leakage current test.
19*	Probe terminal LO	The low voltage input to the human body impedance analog circuit (MD) test bar is typically the low voltage input to the surface leakage current test and the inter-surface leakage current test.

Table 3-2

Note*: *The marking options are all available for TH9130/TH9131.

3.3 Overview of the Instrument Interface Structure

The interface structure of the instrument is schematized as follows.

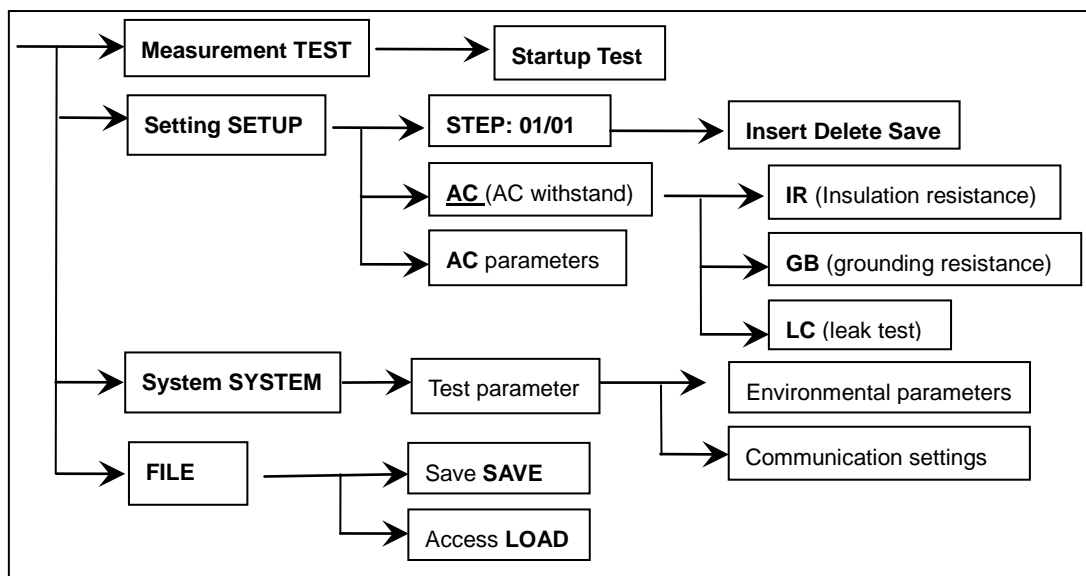

Figure 3-3 Schematic diagram of test operation flow

Interface Description:

- The first column of the interface structure is written in the initial state of the panel's function key invocation as a standard (the specific interface parameters are described in detail later.) The TEST interface cannot modify the parameters.

- The second column of the interface structure is the parameter structure of the initial interface. For example, SETUP interface defaults STEP 01/01: program step 1, total steps 1, AC (AC withstand voltage): AC withstand voltage test interface, AC parameter: other parameters for AC withstand voltage test parameters.

- The third column of the interface structure is the function switching interface, the second interface can be changed by selecting some function symbols, and the related parameters of this interface will be changed. For example, if you change AC to DC, the instrument will change the AC withstand voltage test mode to DC withstand voltage test mode, and the 'AC parameter' in the current interface will be changed to the 'DC parameter' that needs to be set for DC withstand voltage.

3.4 System Parameter SYSTEM Setting

3.4.1 System Test Parameter Setting

Operating Instructions.

- 1、 Press [SYSTEM] key to enter the system setting interface shown in Figure 3-4.
- 2、 Change the system settings related to test, environment, and communication by using the ▲], [▼] arrow keys or knobs, or by touching the screen directly.
- 3、 Move the cursor to the parameter item you want to set. Change the parameter settings

by touching the screen or the F1 to F6 keys or numeric keys. As well as selecting Upgrade, Initialize and Save.

4、 If you need to use numeric key to input, press [ENTER] key to confirm, [ESC] key to reset, [←] key to delete the wrongly input numbers or letters.

The test-related parameter settings in the system setup are shown in Figure 3-4.

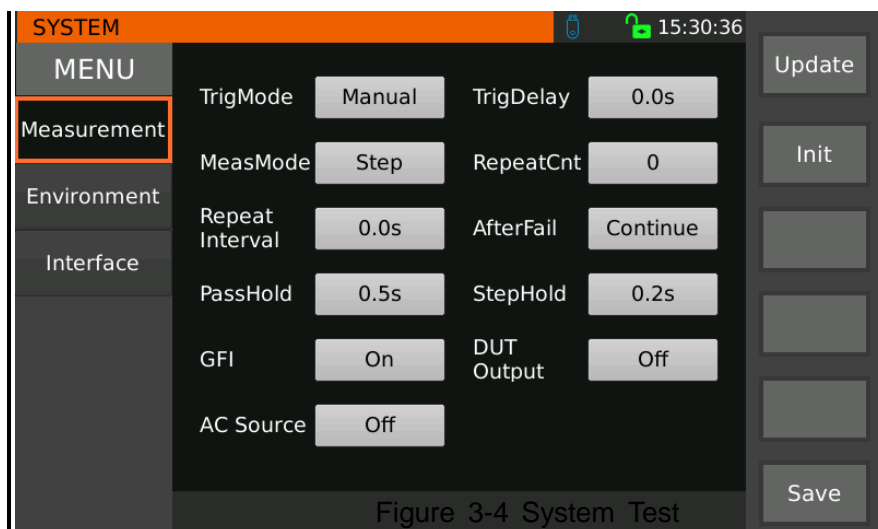

Figure 3-4 System Test

Setting up the project	Configurable range	Default value	Description
Trigger method	Manual/External /Bus	Anually operated	Set the trigger mode in which the instrument starts the test, and only accepts the trigger signal under the current trigger mode.
Trigger delay	0.0 to 99.9s	0.0s	Set the delay time from the reception of the trigger signal to the start of measurement.
Test modes	General test Repeat test Cyclic test Single-step test Breakdown test	General Tests	General Test: Execute only one test according to the file settings. Repeat Test: Execute the test as many times as it is repeated. Cyclic Test: Uninterrupted continuous cyclic test. Single-step test: A test that executes only the current step. Breakdown test: Tests for insulation breakdown points
Repetition	0 to 999	0	The number of repetitions can be set for the above repeated test modes.
Test interval	0.0 to 99.9s	0.0s	For repeated and cyclic tests, set the time interval between two tests.
Test failure	Continue test Retest Stop test Lock	Continue tests	Test failure, that is, after the instrument reported FAIL, you can set whether to continue the next test, or press [START] to re-test, or press [STOP] first, then press [START] to start the test; the lock is the

			need to enter the password after the failure.
Time of qualifying interrogation (QIT)	0.2 to 99.9s	0.5s	Set the duration of buzzer sound when passing (PASS)
Inter-division hold	0.1 to 99.9s/keypad	0.2s	Set the interval time between test steps STEP, the key means to press the [START] key to continue after the test stops. A minimum of 0.8 seconds is maintained between items after the electrical and leakage tests.
AC power (available only for TH9130)	Close/Open	Close	Set whether the instrument's built-in AC power supply is turned on.
Backplane Output (available only for TH9130/31)	Close/Open	Close	Set the backplane DUT and EXTERNAL for high voltage output.
Electrocution protection	Close/Open	Open	Set whether the electric shock protection is turned on.
Table 3-3			

3.4.1.1 Trigger Method

The instrument can only start the test after receiving the trigger signal. The instrument has three trigger modes: manual, external (EXT) and bus (BUS). The instrument can only accept the trigger signal under the current trigger mode, and the trigger signal is only valid under the TEST interface. The instrument ignores other triggers before a measurement is finished and can be triggered again after the measurement is finished, or press the [STOP] key to exit the measurement, and then trigger the measurement again.

- Manual Trigger: Press the [START] key on the panel, the instrument starts to measure.
- External Trigger: A low level greater than 10ms is input externally via the HANDLER interface board.
- Bus Trigger: Send a trigger signal via RS232C or GPIB interface to initiate the test.

The bus trigger method can only be set via bus Commands, as described in detail in section 4.

3.4.1.2 Test Failure

Test failure that is After Fail, refers to the test report FAIL after the processing measures set, divided into continue testing, retesting and stopping the test.

- (1) When CONTINUED TEST CONTINUE is set, when any one of the step STEPs determines that the DUT is defective, the test will continue until all the step STEPs are completed.
- (2) When set to re-test RESTART, the test can be restarted directly by pressing the [START]

key when any one of the steps STEP determines that the part under test is defective.

(3) When set to STOP test STOP, when any one of the steps STEP determines that the tested part is defective, you must press the [STOP] key before you can press the [START] key to restart the test.

3.4.1.3 Test Mode

There are several test modes to choose from, namely normal test, repeat test, cycle test, single-step test, and breakdown test, as shown in Figure 3-5.

Single-step test: If there are multiple test steps in a file, when the test mode is selected as single-step test, only the currently selected test step will be executed. No other test steps will be executed sequentially after this step.

Breakdown Test: Voltage breakdown test is a kind of destructive test in the actual test of the limit ability of the parts to be tested. After selecting the breakdown test mode, press [TEST] key to enter the breakdown test interface, as shown in Figure 3-6.

AC breakdown test or DC breakdown test can be selected through the touch screen or direction keys and knobs, and according to the options in the figure, different starting voltage, termination voltage, and step voltage or number of test steps and other parameters can be selected.

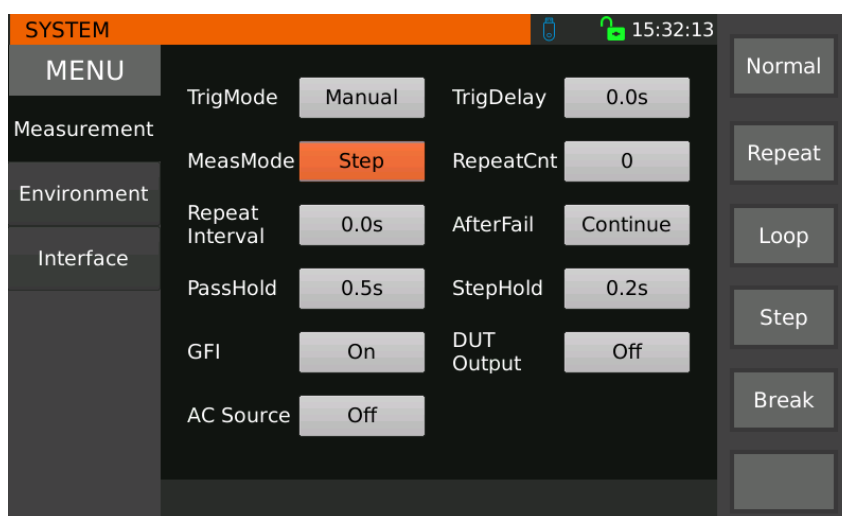

Figure 3-5 Test Mode

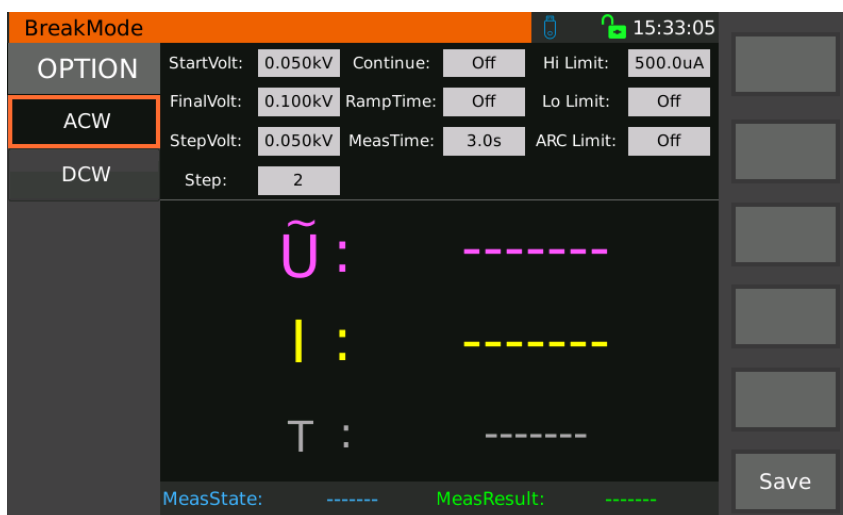

Figure 3-6 Breakdown Test Interface

Setting up the project	Configurable range	Default value	Description
Breakdown Options	AC breakdown / DC breakdown	AC	Selectable mode of breakdown testing AC or DC breakdown
Starting voltage	0.05kV ~ termination voltage	0.05kV	Set voltage starting value
Termination voltage	0.05 ~ 5kV	0.1kV	Set termination voltage value
Step voltage	0.005 ~ 0.5kV	0.05kV	Set the value of the voltage increased at each step
Test steps	2 ~ 999	2	Determined by start and stop and step voltage, also can be set by yourself
Continuous test	Open/Close	Close	Set whether to continue testing after all steps are completed
Rising time	0 ~ 999,0 - Close	Close	Set the rise time for each step
Testing time	0.3 ~ 999s	3.0s	Set the test time for each step
Upper current limit	AC: 0~100mA DC: 0~20mA	0.500mA 0.500mA	Set the upper limit of leakage current
Lower current limit	AC: 0~upper limit value DC: 0~upper limit value 0 - Close	Close Close	Set the lower limit of leakage current
Arc limiting	AC: 0~20mA DC: 0~10mA 0 - Close	Close Close	Set the upper arc limit

Table 3-4

3.4.1.4 Electrocutation Protection

Note: The output power of this instrument can be up to 500VA, the output current is up to 100mA (AC withstand voltage test mode), if electrocution, the situation is already very serious, will cause the operator's coma or even death.

There are two options for the setting item of electric shock protection, which are OFF and ON.

when the electric shock protection is set to ON, when the operator contacts with the high-voltage output, as shown in Figure 3-7, the ammeter measures different current values respectively, then the current $i_3 = i_2 - i_1$ flowing through the human body, and the high-voltage output is cut off immediately when i_3 exceeds the limit value to protect the safety of the operator.

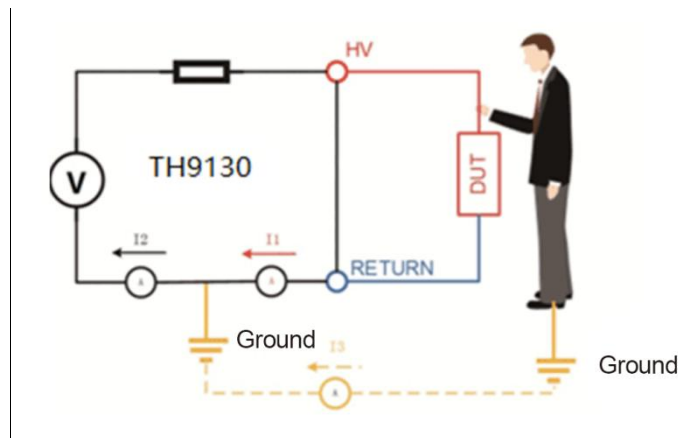

Figure 3-7 Schematic

3.4.1.5 AC Power Supply (only available for TH9130)

The AC power supply is used to provide power to the DUT when the test function is electrical performance test (RUN) or leakage current test (LC).

If the AC power supply setting in Figure 3-4 System Test Parameter Setting is set to "On", the setting option of AC power supply will be added when entering the Electrical Performance Test Setting Interface (Figure 3-29) and Leakage Current Test Setting Interface (Figure 3-33). The output voltage (test voltage), test frequency, upper limit of current, whether zero line is grounded or not (zero-line grounding), voltage range, and overload constant current of AC power supply can be set, and the detailed parameter description can be found in the description of AC power supply in 3.5.6 and 3.5.7.

Note: The AC power supply in this instrument is 500VA open-loop power supply, if this capacity of power supply can not meet the test requirements, you can connect a larger capacity of external AC power supply. At this time, please set "AC Power" to "Off", then you can use the external AC power supply.

3.4.1.6 Backplane Output (only available for TH9130/TH9131)

The Back Panel Output function is used to set whether or not there is a high voltage output from the L&N terminal and the EXTERNAL terminal on the rear panel of the instrument.

If the [Backplane Output] option in the system setting is set to "Off", then the [Backplane Output] option in the setting page of AC Withstand Voltage Test, DC Withstand Voltage Test and Insulation Resistance Test will be "Off" by default. That means the operator can not set the backplane output, at this time, if the test is conducted, only the front panel HV end and the rear panel HV end have high voltage output.

If the option "Backplane Output" in the system setting is set to "On", the option "Backplane Output" in the setting page of AC withstand voltage test, DC withstand voltage test and insulation resistance test will be changed from "Off" to "P-G" (Primary to Ground) option by default, and "S-G" (Secondary to Ground) and "P-S" (Primary to Secondary) can be selected. "P-G" (Primary

to Ground) option, and "S-G" (Secondary to Ground) and "P-S" (Primary to Secondary) can be selected. This function is for an additional high voltage output, which can be tested at multiple points. At this time, if the test is conducted, not only the HV terminal of the front panel and the HV terminal of the rear panel have high-voltage output, but also the L&N terminal or the EXTERNAL terminal of the rear panel have high-voltage output. For details of specific parameter settings, see 3.5.1 for AC withstand voltage test setting instructions.

3.4.2 System Environment Parameter Setting

Operating Instructions:

- 1、 Press **[SYSTEM]** key to enter the system setting interface shown in Figure 3-4.
- 2、 Select by **[▲]** , **[▼]** arrow keys or knob or directly touch the screen to enter the environment-related system setting interface shown in Figure 3-8.
- 3、 Move the cursor to the parameter item you want to set to change the parameter setting.

The environment-related parameter settings in the system setup are shown in Figure 3-8.

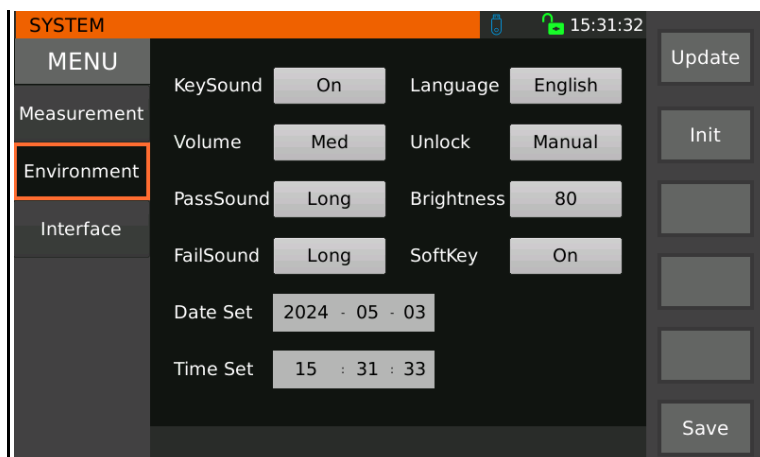

Figure 3-8 System Environment Parameter Settings

Setting up the project	Configurable range	Default value	Description
Keypad sound	Close/Open	Close	Set whether the key sound is turned on or off
System language	Chinese/English	Chinese	Select Chinese or English display
Sound volume	Off / Bass / Midrange / Treble	Soprano	Adjust the buzzer volume
Pushbutton lock	Manual/Bus	Manually operated	Set whether the key lock is set manually or bus-controlled
Qualified sound	Off/Long Tone/Double Short Tone	Long Tone	Set whether the PASS alarm is turned on or not, where the beeping time of the long beep is the value of the PASS setting in the Test column of the System interface.

Screen brightness	1 ~ 100	50	Adjust screen brightness
Bad sound	Off/Long Tone/Double Short Tone	Long Tone	Set the failure (FAIL) alarm sound is turned on, where the long beep for the sound continues to beep until STOP to terminate the beeping
Date Setting	_____	_____	Year, month and day can be set as desired
Time setting	_____	_____	24-hour time can be set as required

Table 3-5

3.4.3 System Communication Settings

Operating Instructions:

- 1、 Press **[[SYSTEM]]** key to enter the system setting interface shown in Figure 3-4.
- 2、 Choose to enter the communication related system setting interface shown in Fig. 3-9 and Fig. 3-10 through **[[▲]]** , **[[▼]]** arrow keys or knob or touch the screen directly.
- 3、 Move the cursor to the parameter item you want to set to change the parameter setting.

The system communication settings are shown in Figure 3-9 and Figure 3-10.

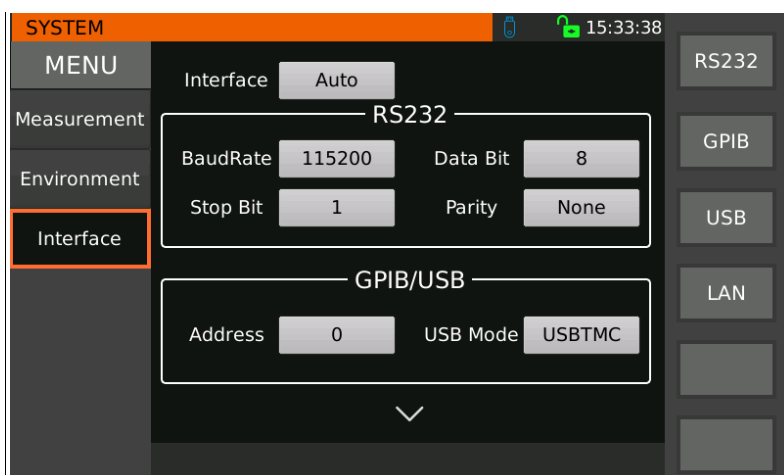

Figure 3-9 System Communication Setup 1

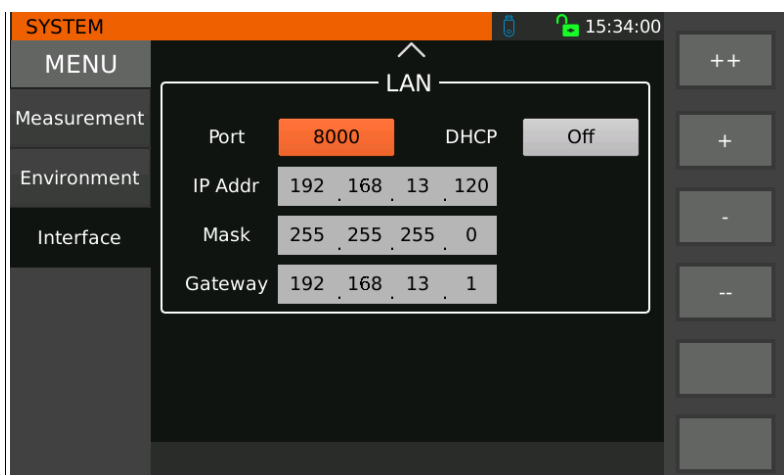

Figure 3-10 System Communication Setup 2

From the above figure, it can be seen that the communication of the instrument is mainly categorized into RS232C, GPIB (optional), USB and LAN. for specific description and detailed explanation, please refer to Chapter 4, Interfaces and Communication section.

3.5 Measurement Setting SETUP Setting

Operating Instructions:

- 1、 Press [SETUP] key to enter the measurement setting interface shown in Figure 3-11.
- 2、 Insertion and deletion of test steps, as well as new file creation and display page turning in case of multiple steps are performed by F1 to F6 keys or touch screen.
- 3、 Touch [Test Mode] option key or [▶] direction key to enter the interface as shown in Fig. 3-12 and Fig. 3-13, you can select different test modes, including AC Withstand Voltage, DC Withstand Voltage, Insulation Resistance, Ground Resistance, Conductance Test, Electrical Test (only TH9130X), Leakage Current (only TH9130X), Open/Short Circuit.
- 4、 Move the cursor to the parameter item you want to set to change the parameter setting.



Figure 3-11 Measurement Setup 1

The changes to the test steps are shown in the following table.

Function	Explanation
Insertion steps	A new test step is added after this step, and the order of the new step and the steps that follow are shifted back one place.
Deletion step	Deletes the current test step and moves the sequence of subsequent steps forward one place.
New file	Create a new test program.
Reproduction steps	Select the current step as the duplicate step and click Insert to insert the same step as the duplicate step.
Preceding page	The page jumps to the display page of the step one step before the current step.
Next page	The page jumps to the display page of the step one step below the current step.

Table 3-6



Figure 3-12 Test Mode Selection 1

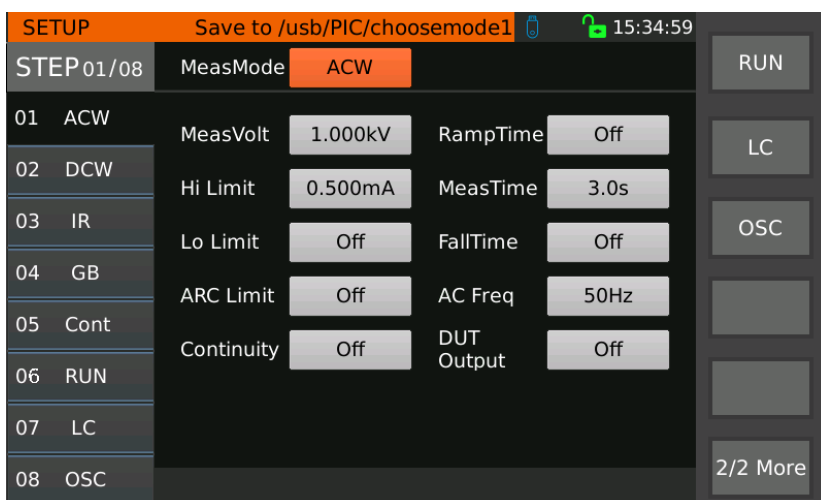

Figure 3-13 Test Mode Selection 2

3.5.1 AC Withstand Voltage Test Setup



Figure 3-14 AC Withstand Voltage Parameter Setting

Setting up the project	Configurable range	Default value	Description
------------------------	--------------------	---------------	-------------

Test pattern	All test modes	--	The current step can be set to the desired test mode
Test voltage	0.050 ~ 5.000 kV. 0 - Close	Close	Setting the required voltage for AC withstand voltage test
Upper current limit	0.001~120.0mA	0.5000mA	Set the upper limit value of the test current. For voltage less than or equal to 4kV, the current can be up to 120mA; for voltage greater than 4kV, the current can be up to 100mA.
Lower current limit	0.001mA ~ upper limit, 0 - off	Close	Set the lower limit value of the test current, the lower limit value should be less than or equal to the upper limit value or off.
Arc limit	1mA to 20mA. 0 - Close	Close	Set the upper limit of the permissible AC arc current. Closed indicates no requirement for an arc.
Test Frequency	50Hz or 60Hz	50Hz	Select frequency of the testing withstand voltage
Rising time	0.1 ~ 999.9s. 0 - Closed	Close	Sets the time it takes to rise to the set voltage. Turn off the rise time and the voltage rise are completed within the first cycle of the test.
Testing time	0.3 ~ 999.9s 0 - Continuous Testing	3.0s	Set the test time for the AC withstand voltage test. Set to 0 to indicate that the test continues until it is ended by pressing STOP.
Falling time	0.1 ~ 999.9s. 0 - Closed	Close	The time it takes for the voltage to drop from the set voltage to a low voltage. Off indicates that the test time is over, and the voltage output is cut off directly.
Conductivity test*	Open/Close	Close	Test whether the ground wire of the DUT is connected reliably to the ground test terminal of this instrument.
Backplane output*	P-G/S-G/P-S	P-G	Setting is allowed only when the backplane output setting in the system settings is turned on.

Table 3-7

Note*: *Marked for TH9130/TH9131 only.

Backplane Output: When the Backplane Output is set to "On" in the System Settings, this function is allowed to be set in the parameter setting of AC Withstand Voltage. The setting interface is shown in the figure. The setting options include [P-G] (Primary to ground), [S-G] (secondary to ground) and [P-S] (Primary to secondary). This function is to have one more high

voltage test terminal, at this time, not only the HV terminals of the front and rear panels have high voltage output, but also one of the corresponding options has high voltage output, as shown in the following table.



Figure 3-15 Backplane Output Parameter Settings

Setting Options	Test High End (High Voltage)	Test Low End	Description
P-G	Rear Panel L&N	Rear Panel CASE	Rear panel L and N terminals shorted for high voltage output, CASE terminal for test low side
S-G	Rear Panel EXTERNAL	Rear Panel CASE	The EXTERNAL end of the rear panel is the high-voltage output, and the CASE end is the test low end.
P-S	Rear Panel L&N	Rear Panel EXTERNAL	Rear panel L and N terminals are shorted for the high voltage output, and the EXTERNAL terminal is the test low side.

Table 3-8

For wiring of the instrument, please refer to the test instructions. Here we take a power supply DUT as an example to make a simple wiring example of the instrument, as shown in the following figure. The L&N terminal on the rear panel of the instrument is connected to the L and N line terminals (AC input) of the DUT, the GND terminal on the rear panel of the instrument is connected to the G line terminal of the DUT, the Case terminal on the rear panel of the instrument is connected to the enclosure or the ground terminal of the DUT, and the EXTERNAL terminal of the instrument is connected to the secondary output terminal (DC output) of the DUT. If P-G is selected, it is to do high-voltage test between L&N terminal and Case terminal; if S-G is selected, it is to do high-voltage test between EXTERNAL terminal and Case terminal; if P-S is selected, it is to do high-voltage test between L&N terminal and EXTERNAL terminal.

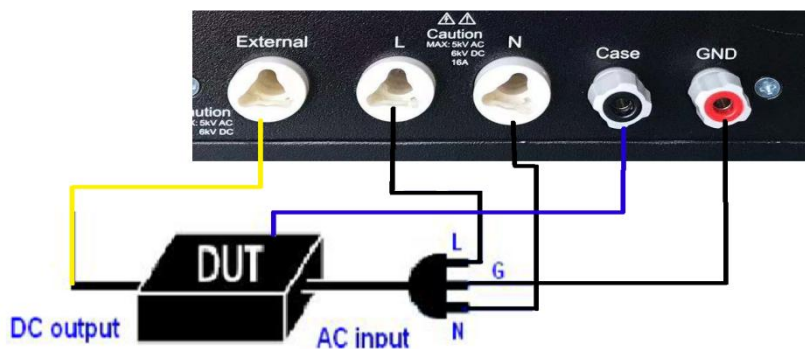

Figure 3-16 Instrument Backplane Wiring Diagram

Conductivity test: Check whether the ground wire of the DUT and the ground test terminal of the instrument are connected reliably. If the option is set to "On", the ground test wire must be connected from the ground test terminal of this sub-instrument to the ground input wire of the DUT, i.e., the resistance from the Case terminal of the rear panel to the GND terminal should be less than 1 ohm. While performing the voltage withstand test, the grounding of the DUT will also be tested. If the ground wire is not connected properly, the voltage withstand test will not be performed. If the ground wire suddenly opens during the test, the withstand voltage test will also be interrupted immediately. If the option is set to "Off", the DUT will not be tested for a ground wire, and it is not necessary to connect the ground wire.

3.5.2 DC Withstand Voltage Test Setup



Figure 3-17 DC Withstand Voltage Setting

Setting up the project	Configurable range	Default value	Description
Test pattern	All test modes	--	The current step can be set to the desired test mode
Test voltage	0.050 ~ 6.000 kV. 0 - Closed	Close	Set the required voltage for DC withstand voltage test
Upper current limit	0.0001mA ~ 25mA	0.5000mA	Set the upper limit value of the test current. For voltage less than 1.5kV, the current can be up to 20mA; for voltage greater than or equal to 1.5kV, the current can be up to 25mA.
Lower	0.0001mA ~ upper	Close	Set the lower limit value of the test current, the

current limit	limit, 0 - off		lower limit value should be less than or equal to the upper limit value or off.
Rising judgment	Close/Open	Close	When the creepage judgment setting is turned on, the DC withstand voltage test will judge whether the current test value exceeds the current limit setting value when the rise time is executed. When the creepage judgment is set to off, the DC withstand voltage test will not judge whether the current test value exceeds the upper current limit setting when the rise time is executed.
Rising Arc	1mA ~ 10mA 0 - Close	Close	Set the upper limit of the arc current when the DC voltage rises. Closed indicates that there is no requirement for arcing as the voltage rises.
Arc limiting	1mA ~ 10mA 0 - Close	Close	Set the upper limit of the permissible DC arc current. Closed indicates no requirement for an arc.
Rising time	0.1 ~ 999.9s 0 - Close	Close	Sets the time it takes to rise to the set voltage. Turn off the rise time and the voltage rise is completed within the first cycle of the test.
Delay time	0.1 ~ 999.9s 0 - Close	Close	Set the time required for waiting (during the time of delayed opening, the upper and lower current limit values are not judged, but subject to not exceeding the upper limit of the set current slot).
Testing time	0.3 ~ 999.9s 0 - Continuous Testing	3.0s	Set the test time for the DC withstand voltage test. Set to 0 to indicate that the test continues until it is ended by pressing STOP.
Falling time	0.1 ~ 999.9s. 0 - Closed	Close	The time it takes for the voltage to drop from the set voltage to a low voltage. Off indicates that the test time is over, and the voltage output is cut off directly. (Tested parts may be electrically charged)
Conductivity test*	Open/Close	Close	Test whether the ground wire of the DUT is connected reliably to the ground test terminal of this instrument.
Backplane output*	P-G/S-G/P-S	P-G	Setting is allowed only when the backplane output setting in the system settings is turned on.

Table 3-9

Note*: *Marked for TH9130/TH9131 only.

Backplane Output: When the Backplane Output is set to "On" in the System Settings, this function is allowed to be set in the parameter setting of DC Withstand Voltage. The setting interface is shown in the figure. The setting options include $\llbracket P-G \rrbracket$ (Primary to ground), $\llbracket S-G \rrbracket$ (secondary to ground) and $\llbracket P-S \rrbracket$ (Primary to secondary). This function is to have one more high voltage test terminal, at this time, not only the HV terminals of the front and rear panels have high voltage output, but also one of the corresponding options has high voltage output, as shown in the

following table.



Figure 3-18 Backplane Output Settings

Setting Options	Test High End (High Voltage)	Test Low End	Description
P-G	Rear Panel L&N	Rear Panel CASE	Rear panel L and N terminals shorted for high voltage output, CASE terminal for test low side
S-G	Rear Panel EXTERNAL	Rear Panel CASE	The EXTERNAL end of the rear panel is the high-voltage output, and the CASE end is the test low end.
P-S	Rear Panel L&N	Rear Panel EXTERNAL	Rear panel L and N terminals are shorted for the high voltage output, and the EXTERNAL terminal is the test low side.

Table 3-10

For wiring of the instrument, please refer to the test instructions. Here we take a power supply DUT as an example to make a simple wiring example of the instrument, as shown in the following figure. The L&N terminal on the rear panel of the instrument is connected to the L and N line terminals (AC input) of the DUT, the GND terminal on the rear panel of the instrument is connected to the G line terminal of the DUT, the Case terminal on the rear panel of the instrument is connected to the enclosure or the ground terminal of the DUT, and the EXTERNAL terminal of the instrument is connected to the secondary output terminal (DC output) of the DUT. If P-G is selected, it is to do high-voltage test between L&N terminal and Case terminal; if S-G is selected, it is to do high-voltage test between EXTERNAL terminal and Case terminal; if P-S is selected, it is to do high-voltage test between L&N terminal and EXTERNAL terminal.

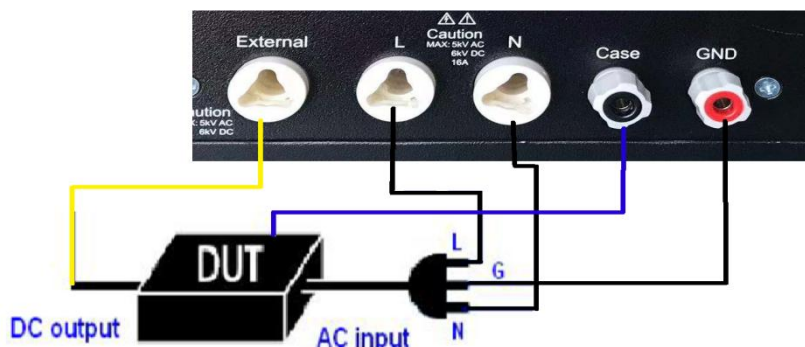

Figure 3-19 Instrument Backplane Wiring Diagram

Conductivity test: Check whether the ground wire of the DUT and the ground test terminal of the instrument are connected reliably. If the option is set to "On", the ground test wire must be connected from the ground test terminal of this sub-instrument to the ground input wire of the DUT, i.e., the resistance from the Case terminal of the rear panel to the GND terminal should be less than 1 ohm. While performing the voltage withstand test, the grounding of the DUT will also be tested. If the ground wire is not connected properly, the voltage withstand test will not be performed. If the ground wire suddenly opens during the test, the withstand voltage test will also be interrupted immediately. If the option is set to "Off", the DUT will not be tested for a ground wire, and it is not necessary to connect the ground wire.

3.5.3 Insulation Resistance Test Setup



Figure 3-20 Insulation Resistance Setting

Setting up the project	Configurable range	Default value	Description
Test pattern	All test modes	--	The current step can be set to the desired test mode
Test voltage	0.050 ~ 6.000kV, 0 - off	Close	Set the required voltage for insulation resistance testing
Lower limit of resistance	0.05M ~ 50GΩ	1.000MΩ	Set the lower limit of insulation resistance
Upper limit of resistance	Lower limit value ~50GΩ 0 - Close	Close	Set the upper limit of insulation resistance, greater than the lower limit of insulation resistance or off.

Rising time	0.1 ~ 999.9s 0 - Close	Close	Set the time it takes to rise to the set voltage. Turn off the rise time and the voltage rise are completed within the first cycle of the test.
Delay time	0.1 ~ 999.9s 0 - Close	Close	Sets the delay time for the insulation resistance test, which can be used to wait for the test value to stabilize, off means no delay time.
Testing time	0.3 ~ 999.9s 0 Continuous Testing	3.0s	Set the test time for the insulation resistance test. Set to 0 to indicate that the test continues until it is ended by pressing STOP.
Falling time	0.1 ~ 999.9s 0 - Close	Close	The time it takes for the voltage to drop from the set voltage to a low voltage. Off indicates that the test time is over, and the voltage output is cut off directly.
Test range	Auto, 10mA, 3mA, 300uA, 30uA, 3uA, 300nA	Auto	Set the current test range of insulation resistance, auto range Automatically switches to the corresponding range according to the change of test value, and fixed range means fixed at the selected range.
Backplane output*	P-G/S-G/P-S	P-G	Setting is allowed only when the backplane output setting in the system settings is turned on.
Table 3-11			

Note*: *Marked for TH9130/TH9131 only.

Auto Ranging: To select the appropriate current range for IR, please calculate the current based on the test voltage and the insulation impedance of the object to be measured, i.e. $I = U/R$, and then select the appropriate current range accordingly. The relationship between current range and resistance measurement range is shown in Table 3-8 below.

Current range	Resistance Measurement Range	
	set voltage 50V to 499V	set voltage 500V to 6000V
10mA(3~10mA)	0.05MΩ~1MΩ	0.05MΩ~4.5MΩ
3mA(0.3~3mA)	0.5MΩ~4.5MΩ	3.0MΩ~15.0MΩ
300uA (30 to 300uA)	3.0MΩ~15.0MΩ	10.0MΩ~45MΩ
30uA(3~30uA)	10.0MΩ~45MΩ	35.0MΩ~450MΩ
3uA(0.3~3uA)	45MΩ~0.45GΩ	0.40GΩ~4.5GΩ
300nA(20~300nA)	0.40GΩ~4.9G Ω	4.0GΩ~50.0GΩ
Table 3-12		

Backplane Output: Same settings as for AC withstand voltage and DC withstand voltage tests, see 3.5.1 and 3.5.2 for details on backplane output.

3.5.4 Ground Resistance Test Setup

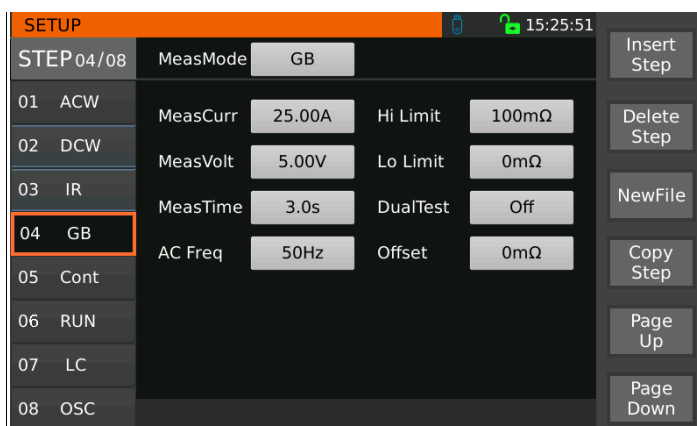

Figure 3-21 Grounding Resistance Setting

Setting up the project	Configurable range	Default value	Description
Test pattern	All test modes	--	The current step can be set to the desired test mode
Test Current	1.00 ~ 40.00A	25.00A	Set the current required for the ground resistance test.
Test voltage	3.00 ~ 8.00V	5.00V	Set the voltage required for the ground resistance test.
Testing time	0.5 ~ 999.9s 0 - Continuous Testing	3.0s	Set the test time for the grounding resistance test. Set to 0 to indicate that the test continues until it is ended by pressing STOP.
Test Frequency	50Hz/60Hz	50Hz	Set the frequency of the grounding resistance test current.
Resistance Limit	0~600mΩ	100mΩ	Set the upper limit of grounding resistance. 0 to 600mΩ (1.00 to 10.00A) 0 to 200mΩ (10.01 to 30.00A) 0 to 150mΩ (30.01 to 40.00A)
Lower limit of resistance	0mΩ ~ upper resistance limit	0mΩ	Set the lower limit value of grounding resistance.
Synchronized testing	Off / AC withstand voltage / DC withstand voltage	Close	Set the grounding resistance test and voltage withstand test to be output for testing at the same time.
Compensation settings	0-200mΩ	0mΩ	Zeroing values are set manually and Automatically on the test screen.

Table 3-13

Test Voltage: This test voltage setting mainly lies in limiting the maximum voltage of the

output open circuit, that is, setting the output voltage in constant voltage mode, while the grounding resistance test is constant current test mode, if the actual test current can not reach the set current, the test voltage can be set to 8V.

Synchronized Test: Ground resistance test and voltage withstand test output test at the same time. The option setting is categorized into Off, AC Withstand Voltage, and DC Withstand Voltage, as shown in Figure 3-22. If the setting is AC Withstand Voltage, the grounding resistance and AC Withstand Voltage will be tested at the same time during the test; if the setting is DC Withstand Voltage, the grounding resistance and DC Withstand Voltage will be tested at the same time; and if the setting is Off, this function will be turned off.

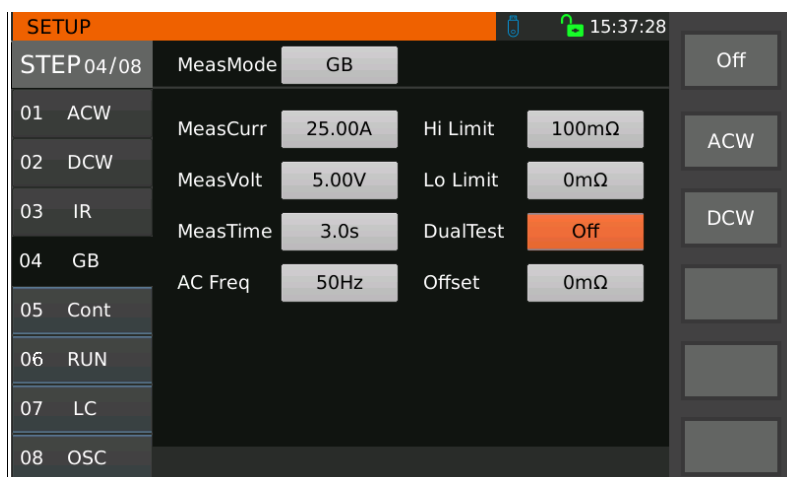

Figure 3-22 Ground Resistance Synchronization Test Setup

As an example, if the option is set to AC withstand voltage, the following explanation is given:

When the synchronized test is set to AC withstand voltage, the test step will Automatically add an AC withstand voltage step, as shown in Figure 3-23, select the new AC withstand voltage test step, enter the parameter setting interface of AC withstand voltage, and set the corresponding parameters, as shown in Figure 3-24. Press [TEST] to enter the test interface, as shown in Figure 3-25, you can see the main parameter display column, both the parameters of grounding resistance and the main test parameters of AC withstand voltage.

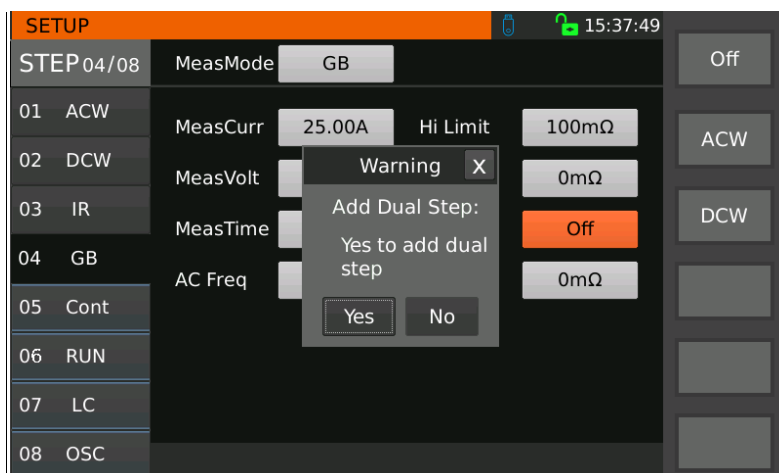

Figure 3-23 Simultaneous testing of grounding resistance and AC withstand voltage

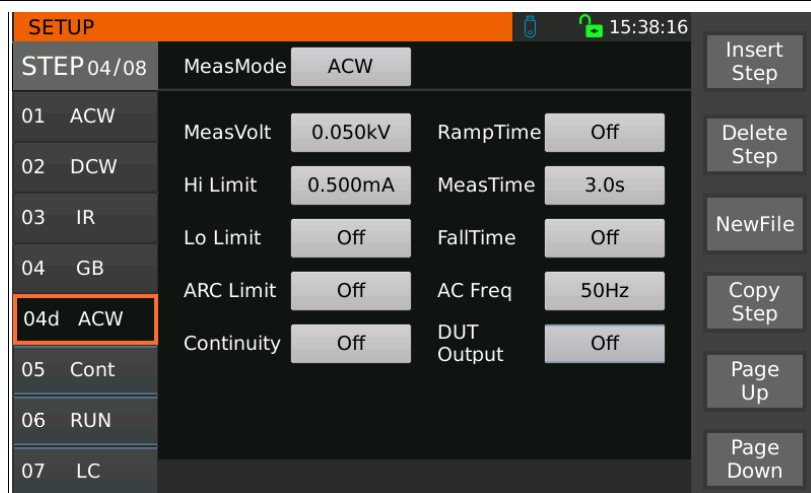

Figure 3-24 AC Withstand Voltage Setup for Synchronized Testing

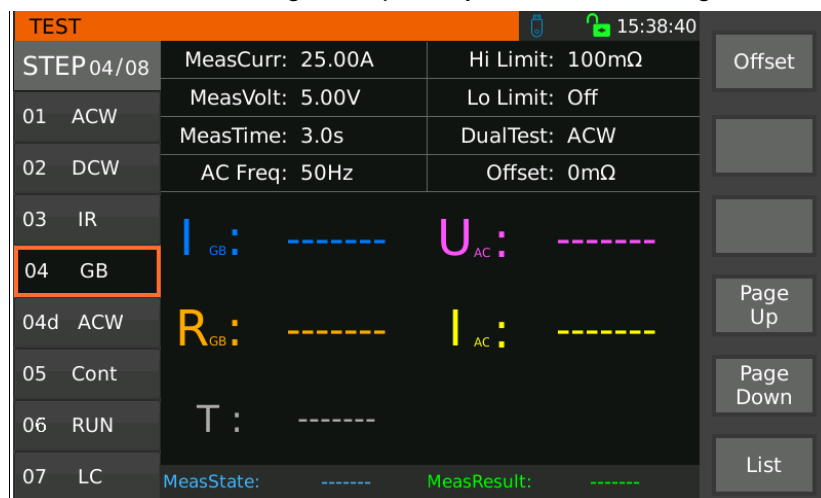

Figure 3-25 Measurement Display for Synchronization Test

3.5.5 Conductivity Test Setup

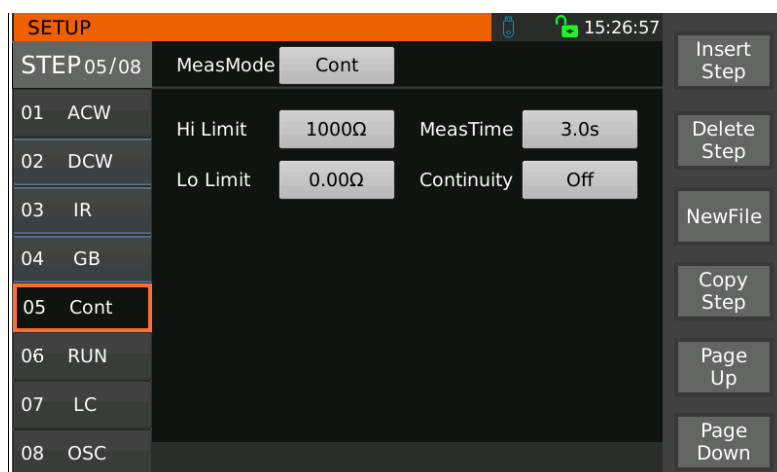

Figure 3-26 Conductivity Test Setup

Setting up the project	Configurable range	Default value	Description
Test pattern	All test modes	--	The current step can be set to the desired test mode

Resistance Limit	0.00Ω~10000Ω	1000Ω	Set the upper limit value of the on-state test resistance.
Lower limit of resistance	0.00Ω~ upper resistance limit	0.00Ω	Set the lower limit value of the on-state test resistance.
Testing time	0.3 ~ 999.9s 0 - Continuous Testing	3.0s	Set the test time for the conduction test. Set to 0 to indicate that the test continues until it is ended by pressing STOP.
Conductivity test*	GND/Off/L-N	Off	On-resistance test, testing the resistance value between different detection terminals.
Table 3-14			

Note*: *MArking available for TH9130/TH9131 only.

On-resistance test: On-resistance test, can test the resistance between different detection terminals, adding the DUT L to N test application, which can detect the DUT (DUT) L line to the N line of the internal impedance, to prevent the DUT L and N short circuit or abnormalities caused by the danger of power supply. As shown in Figure 3-27, click on "Conductivity Test" to select GND, Off, and L-N options.

If GND is selected, the instrument detects the internal impedance from the Case end of the rear panel to the GND end.

If OFF is selected, the instrument detects the internal impedance of the instrument itself from the Current end to the Return end:

If L-N is selected, the instrument detects the internal impedance from the L terminal to the N terminal of the rear panel.

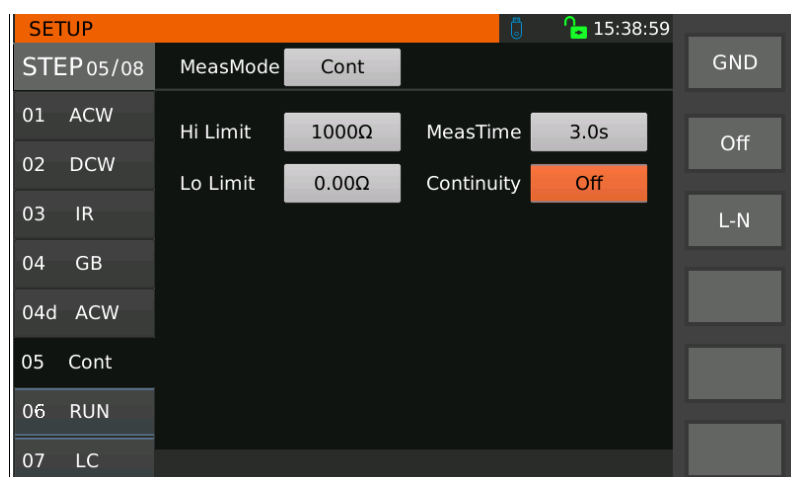

Figure 3-27 On-resistance Setting

3.5.6 Electrical Test Setup (only available for TH9130/TH9131)

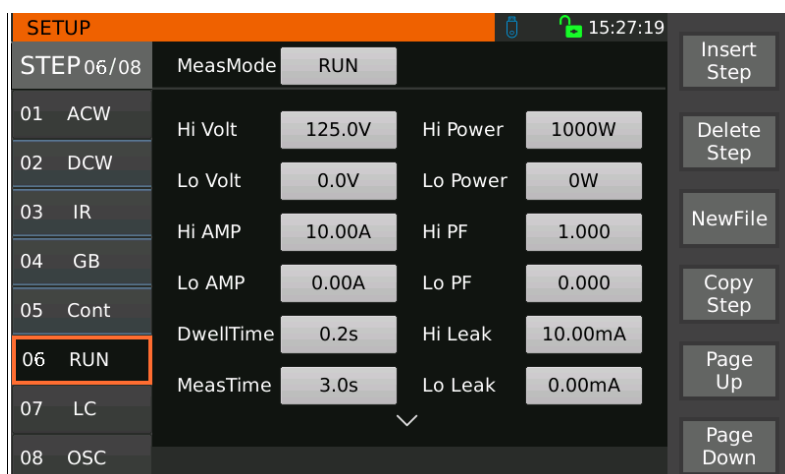

Figure 3-28 Electrical Test Setup

Setting up the project	Configurable range	Default value	Description
Test pattern	All test modes	--	The current step can be set to the desired test mode
Upper voltage limit	0.0 ~ 277.0V	125.0V	Set the upper voltage limit for electrical tests
Lower voltage limit	0.0V ~ upper voltage limit	0.0V	Set the lower voltage limit for electrical tests
Upper current limit	0.00 ~ 16.00A	10.00A	Set the upper current limit for electrical tests
Lower current limit	0.00A ~ upper current limit	0.00A	Set the lower current limit for electrical tests
Waiting time	0.2 ~ 999.9s	0.2s	Set the time required for waiting (during the waiting time, the upper and lower current limit values will not be judged, but if the current limit value of the instrument hardware is exceeded, the test will be reported as failed).
Testing time	0.1 ~ 999.9s 0 - Continuous Testing	3.0s	Set the test time for the electrical test. Set to 0 to indicate that the test continues until it is ended by pressing STOP.
Upper power limit	0 ~ 4500W	1000W	Set the upper power limit for electrical tests

Lower limit of power	0 ~ upper power limit	0W	Set the lower power limit for electrical tests
Upper limit of power factor	0.000 ~ 1.000	1.000	Set the upper power factor limit for electrical tests
Lower limit of power factor	0.000 ~ upper limit of power factor	0.000	Set the lower power factor limit for electrical tests
Upper limit of leakage	0.00 ~ 10.00mA 0- Close	10.00mA	Set the upper limit of leakage current
lower limit of leakage	0.00 ~ upper leakage limit	0.00mA	Set the lower limit of leakage current
Remote control	Memory group 1 - Memory group 7	Memory group 1	The output of the AC power supply TH71XX can be remotely controlled.

Table 3-15

AC Power Supply (only available for TH9130): If AC Power Supply is set to On in the System Setup, there is a setup screen as shown below in the Setup screen of Electrical Test.

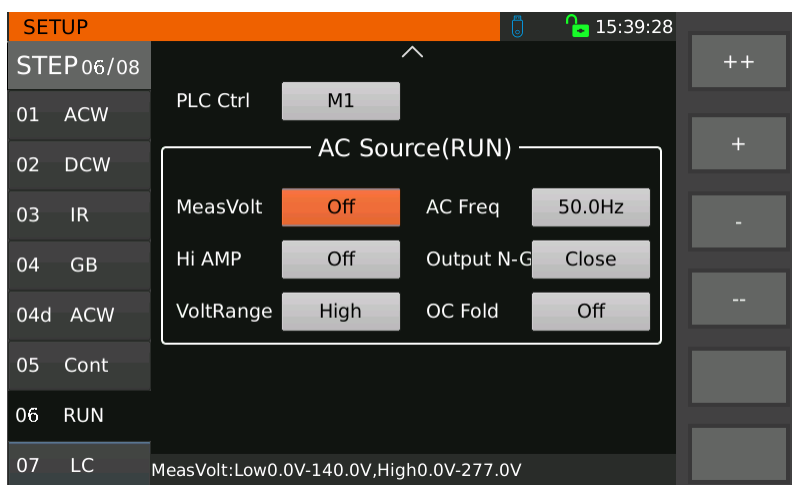

Figure 3-29 AC Power Setup

Setting up the project	Configurable range	Default value	Description
Test voltage	0.0 ~ 277.0V 0.0 ~ 140.0V	Close	Set the test voltage of the AC power supply. Higher/lower voltage ranges correspond to different ranges.
Test	45.0 ~ 500.0 Hz	50Hz	Set the test frequency of the AC power

Frequency			supply
Upper current limit	0.0 ~ 2.1A 0.0 ~ 4.2A	Close	Set the upper test current limit for the AC power supply. Higher/lower voltage ranges correspond to different ranges.
Zero-line ground	Disconnect/Close	Close	Set whether the zero wire of the AC power supply is grounded.
Voltage range	Upscale/downscale	Upscale	Set the voltage range of the AC power supply.
Overload constant current	Open/Close	Close	If it is set to open, when the output current is greater than the upper current limit setting value, it will continue to output at the set current value (the test voltage will drop) without protection; if it is set to close, when the output current is greater than the upper current limit setting value, the instrument will stop output immediately.

Table 3-16

3.5.7 Leakage Current Test Setup (only available for TH9130/TH9131)

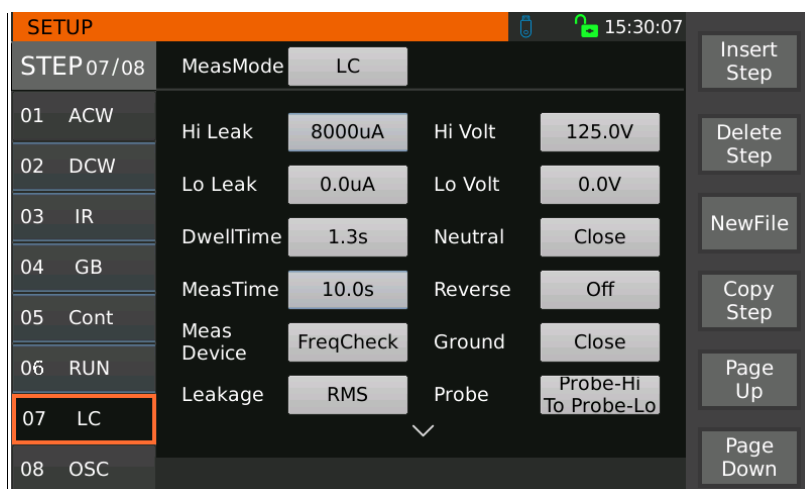

Figure 3-30 Leakage Current Setting 1

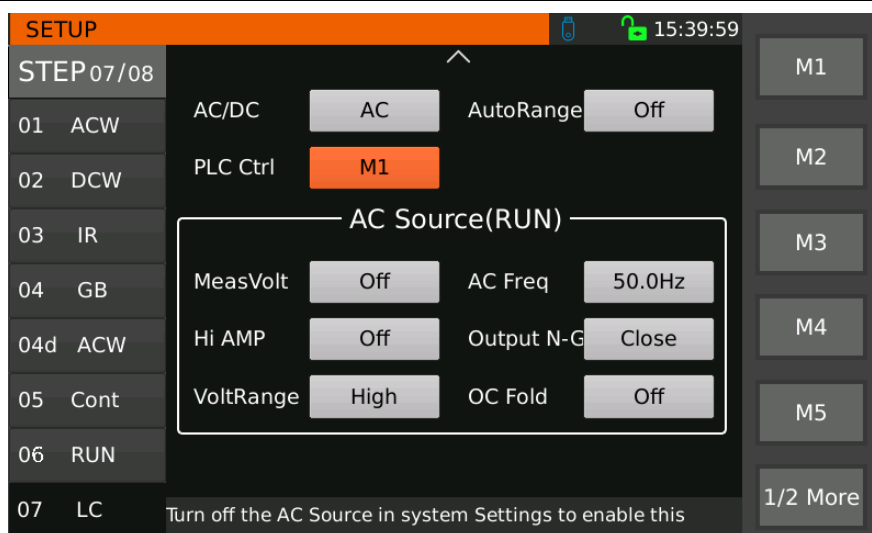

Figure 3-31 Leakage Current Setting 2

Setting up the project	Configurable range	Default value	Description
Test pattern	All test modes	--	The current step can be set to the desired test mode
Leakage limit	0.0 ~ 10000uA	6000uA	Set the upper limit of leakage current for leakage testing
Lower limit of leakage	0.0 ~ upper leakage limit	0.0uA	Set the lower limit of leakage current for leakage test
Voltage limit	0.0 ~ 277.0V	125.0V	Set the upper voltage limit for leakage testing
Lower voltage limit	0.0V ~ upper voltage limit	0.0V	Set the lower voltage limit for leakage testing
Waiting time	0.5 ~ 999.9s	0.5s	Set the time required to wait for a leak test. The settable range varies depending on the test settings.
Testing time	0.1 ~ 999.9s 0 - Continuous Testing	3.0s	Set the test time for the leak test. The settable range varies depending on the test settings. Set to 0 to indicate that the test continues until it is ended by pressing STOP.
Zero-line switch	Disconnect/Close	Close	Set the status of the power supply zero line for leakage testing
Polarity switch	On/Off/Auto	Close	Set the power polarity state for leakage testing
Grounding switch	Disconnect/Close	Close	Set the power ground state for leak testing
Ecological network	See description below	UL544NP	Set up the human body impedance network model for leakage testing, as

			detailed in the specific national and international standards in the technical specifications.
Leakage current	RMS/Peak	Effective value	Set the mode of the tested leakage current value.
Probe settings	Ground-to-ground line of fire Probe to firewire Probe to probe	Ground-to-ground line of fire	Set the probe position for leak testing. See description below for detailed instructions.
Ac/dc	AC/DC /AC+DC	AC + DC	Set the leakage current to AC, DC or AC+DC.
Auto range	Open/Close	Open	Set the current test range for leakage test, switch to the corresponding range Automatically according to the change of the test value when turning on the auto-range and close the auto-range to fix it at the selected range.
Remote control	Memory group 1 - Memory group 7	Memory group 1	The output of the AC power supply TH71XX can be remotely controlled.

Table 3-17

3.5.7.1 DUT Working Condition

The operating power state setting of the object to be measured is determined by switches S1, S2, and S3. (S1 stands for Neutral Switch, i.e., Zero Line Switch; S2 stands for Reverse Polarity Switch, i.e., Polarity Switch; S3 stands for Ground Switch, i.e., Ground Switch.) As shown in Figure 4-30 below, these three switches can have eight combinations of states. To change the working power state of the object to be measured, simply check the corresponding switch option, and then select the upper-right corner option to enter the corresponding switch setting interface.

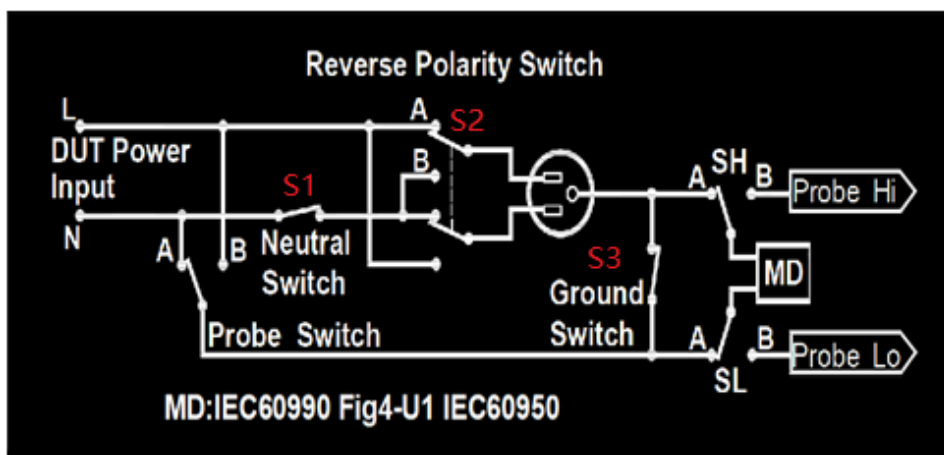
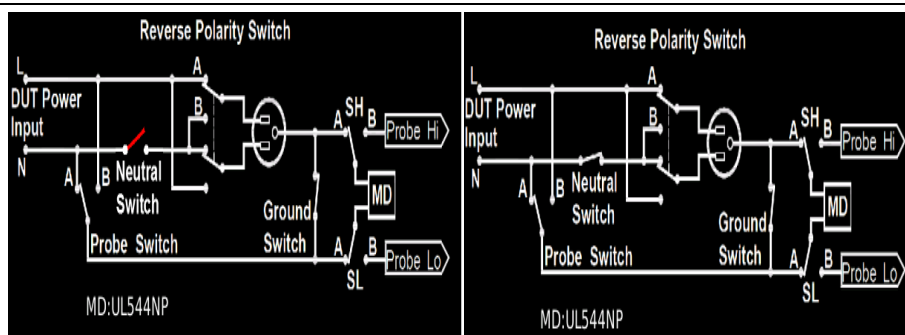

Figure 3-32 Power state setting for the object to be measured

The Neutral Zero switch has both open and closed options, and the corresponding schematic is shown below.



Disconnect Diagram

Closed Diagram

The Reverse Polarity Switch has three options: On, Off and Auto, and the corresponding schematic diagrams for On and Off are shown in the figure below. When Reverse is selected as Auto, the instrument will test the leakage current value of the line with Reverse switch in "open" and "closed" state respectively, and then take the larger one as the final leakage current value.

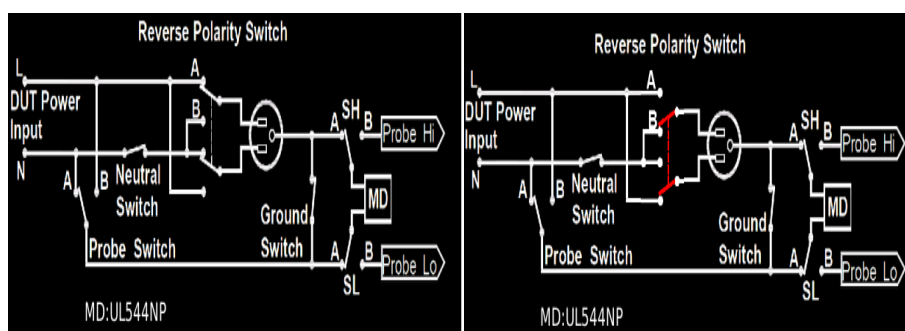

Open Diagram

Close Diagram

The Ground Ground switch has two options, Disconnect and Close, and the corresponding schematic is shown below.

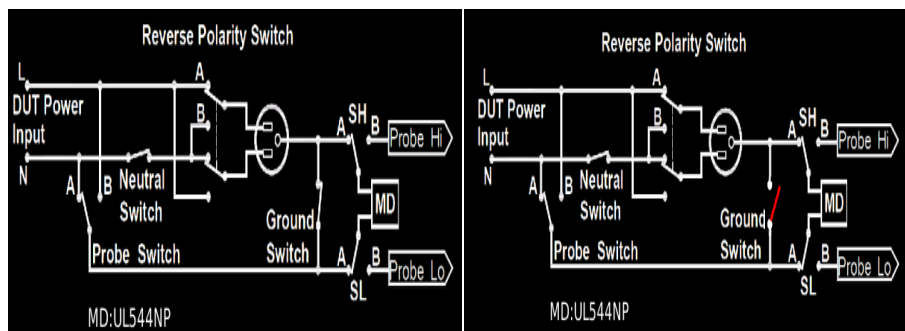

Disconnect Diagram

Close Diagram

After selecting the required working power state (page selection confirmation), you can press the [TEST] key to enter the test interface, press the [START] green key to start the test, the instrument will Automatically store the selected working power state into the instrument. The working power of the object to be tested has 12 settings and eight states, as shown in Table 3-18.

Setting the category	Neutral	Reverse	Ground	Power status of the object to be measured
	Zero-line switch S1	Reverse polarity S2	Ground switch S3	
1	Close	Close	Turn off	Status I
2	Close	Open	Turn off	Status II
3	Turn off	Close	Turn off	Status III

4	Turn off	Open	Turn off	Status IV
5	Close	Close	Close	Status V
6	Close	Open	Close	Status VI
7	Turn off	Close	Close	Status VII
8	Turn off	Open	Close	Status VIII
9	Close	Auto	Turn off	Status 1 & Status 2
10	Turn off	Auto	Turn off	Status III & IV
11	Close	Auto	Close	Status V & Status VI
12	Turn off	Auto	Close	Status VII & VIII

Table 3-18

The operating power settings for the eight Status are shown below:

Status I: General standardized test (Class I products)

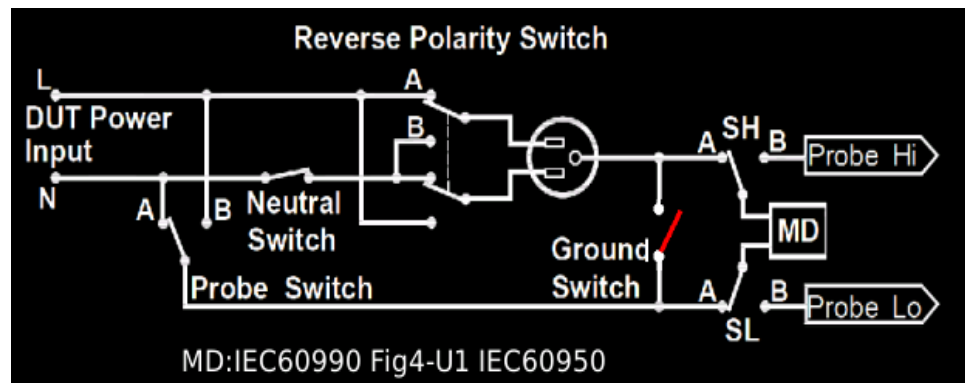

Neutral: Closed; Reverse: Closed; Ground: Disconnected

Status II: L and N reverse test (Class I products)

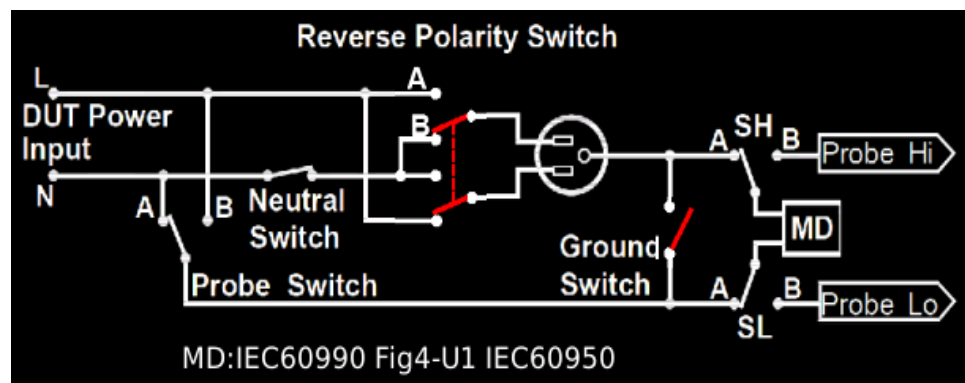

Neutral: Closed; Reverse: Open; Ground: Disconnected

Status III: Single Failure Test (Class I product)

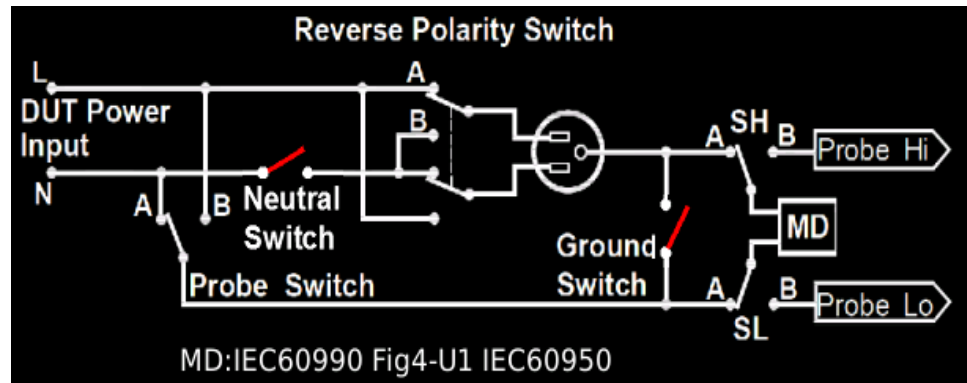

Neutral: Disconnect; Reverse: Closed; Ground: Disconnect

Status IV: Single fault and L and N reverse tested (Class I products)

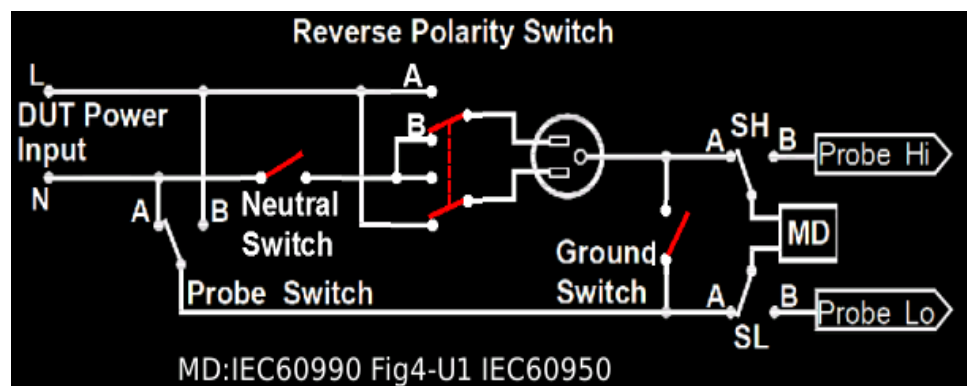

Neutral: Disconnect; Reverse: Open; Ground: Disconnect

Status V: Single Fault Test (Class II products)

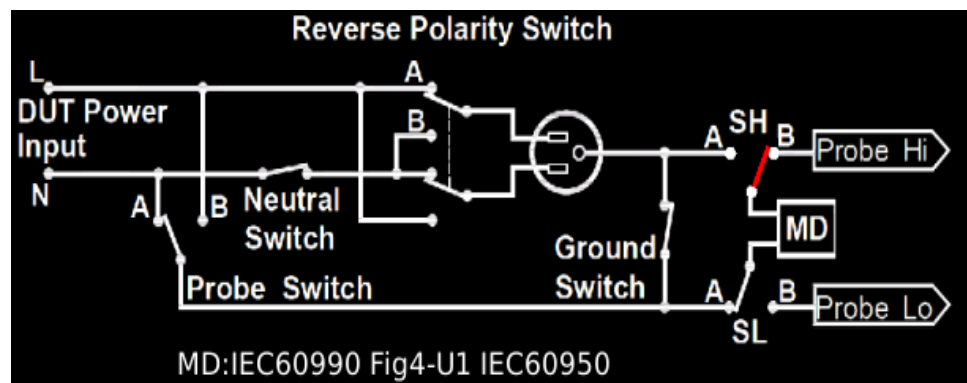

Neutral: Closed; Reverse: Closed; Ground: Closed

Status VI: L, N reverse test (Class II products)

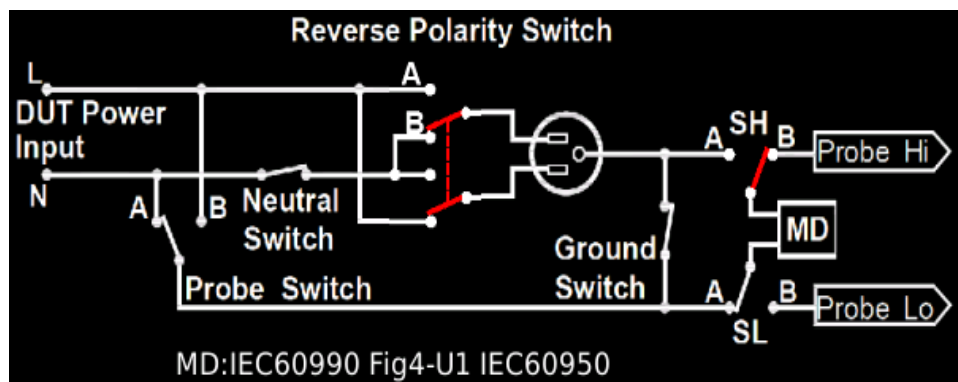

Neutral: Closed; Reverse: Open; Ground: Closed

Status VII: Single failure test (Class II products)

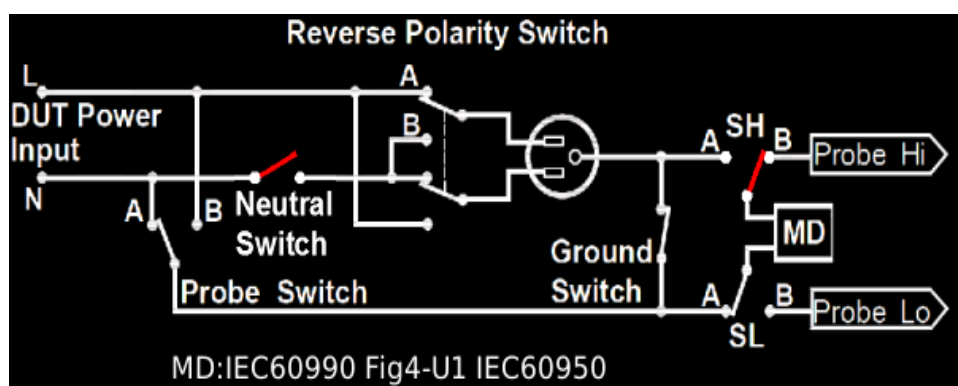

Neutral: Disconnect; Reverse: Close; Ground: Close

Status VIII: Single fault with L and N reverse test (Class II products)

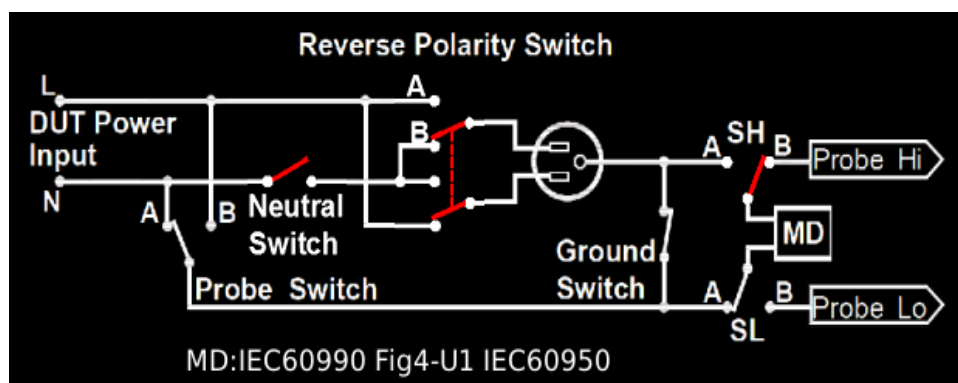

Neutral: Disconnect; Reverse: Open; Ground: Close

3.5.7.2 Human Impedance Network Modeling

Human body network refers to the model of human impedance network, select "Human body network" in the setting interface, and then select "Human body network" in the upper right corner, the instrument interface will pop up the picture of the corresponding impedance network model available for selection, as shown in the figure. For specific national and international standards, please refer to the technical specifications.

UL544NP

Measure Device	UL544NP	UL544P
UL544NP	UL544P	
IEC60601-1	UL1563	
IEC60990 Fig4-U1	IEC60990 Fig4-U2	
IEC60990 Fig5-U1	IEC60990 Fig5-U3	
IEC61010-1 A.2	IEC60598 FigG.4	
Especial Network	FreqCheck	
Cancel	Yes	

UL544P

Measure Device	UL544NP	UL544P
UL544NP		UL544P
IEC60601-1	UL1563	
IEC60990 Fig4-U1	IEC60990 Fig4-U2	
IEC60990 Fig5-U1	IEC60990 Fig5-U3	
IEC61010-1 A.2	IEC60598 FigG.4	
Especial Network	FreqCheck	
Cancel	Yes	

IEC60601, GB9706.1

Measure Device	UL544NP	UL544P
UL544NP	UL544P	
IEC60601-1	UL1563	
IEC60990 Fig4-U1	IEC60990 Fig4-U2	
IEC60990 Fig5-U1	IEC60990 Fig5-U3	
IEC61010-1 A.2	IEC60598 FigG.4	
Especial Network	FreqCheck	
Cancel	Yes	

UL1563

Measure Device	UL544NP	UL544P
UL544NP	UL544P	
IEC60601-1	UL1563	
IEC60990 Fig4-U1	IEC60990 Fig4-U2	
IEC60990 Fig5-U1	IEC60990 Fig5-U3	
IEC61010-1 A.2	IEC60598 FigG.4	
Especial Network	FreqCheck	
Cancel	Yes	

IEC60990 Fig4-U1, GB4706.1

Measure Device	UL544NP	UL544P
UL544NP	UL544P	
IEC60601-1	UL1563	
IEC60990 Fig4-U1	IEC60990 Fig4-U2	
IEC60990 Fig5-U1	IEC60990 Fig5-U3	
IEC61010-1 A.2	IEC60598 FigG.4	
Especial Network	FreqCheck	
Cancel	Yes	

IEC60990 Fig4-U2, GB12113.1

Measure Device	UL544NP	UL544P
UL544NP	UL544P	
IEC60601-1	UL1563	
IEC60990 Fig4-U1	IEC60990 Fig4-U2	
IEC60990 Fig5-U1	IEC60990 Fig5-U3	
IEC61010-1 A.2	IEC60598 FigG.4	
Especial Network	FreqCheck	
Cancel	Yes	

IEC60990 Fig5-U1, GB7000.1

Measure Device	UL544NP	UL544P
UL544NP	UL544P	
IEC60601-1	UL1563	
IEC60990 Fig4-U1	IEC60990 Fig4-U2	
IEC60990 Fig5-U1	IEC60990 Fig5-U3	
IEC61010-1 A.2	IEC60598 FigG.4	
Especial Network	FreqCheck	
Cancel	Yes	

IEC60990 Fig5-U3, GB12113.1

Measure Device	UL544NP	UL544P
UL544NP	UL544P	
IEC60601-1	UL1563	
IEC60990 Fig4-U1	IEC60990 Fig4-U2	
IEC60990 Fig5-U1	IEC60990 Fig5-U3	
IEC61010-1 A.2	IEC60598 FigG.4	
Especial Network	FreqCheck	
Cancel	Yes	

IEC61010-1 A.2, GB4793.1

Measure Device	UL544NP	UL544P
UL544NP	UL544P	
IEC60601-1	UL1563	
IEC60990 Fig4-U1	IEC60990 Fig4-U2	
IEC60990 Fig5-U1	IEC60990 Fig5-U3	
IEC61010-1 A.2	IEC60598 FigG.4	
Especial Network	FreqCheck	
Cancel	Yes	

IEC60598FigG.4, GB7000.1

Measure Device	UL544NP	UL544P
UL544NP	UL544P	
IEC60601-1	UL1563	
IEC60990 Fig4-U1	IEC60990 Fig4-U2	
IEC60990 Fig5-U1	IEC60990 Fig5-U3	
IEC61010-1 A.2	IEC60598 FigG.4	
Especial Network	FreqCheck	
Cancel	Yes	

Special Needs Networks

Frequency Detection

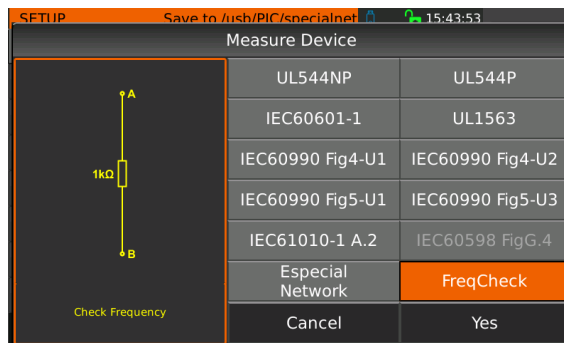
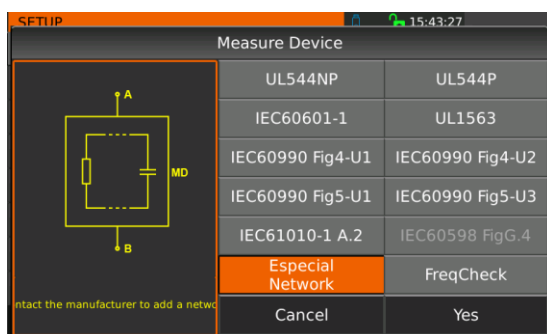

IEC60598FigG.4, GB7000.1: If this network is required, please contact the manufacturer to add it.

Special network: According to the human body impedance model required by the customer, another test model can be added, and the program can be re-upgraded to match the model impedance.

Frequency detection: Leakage current test bandwidth detection, test probe selection Probe Hi and Probe Lo terminals, the human body impedance network model selection "frequency detection", at this time the built-in MD impedance is 1kΩ, you can use the two test probes directly connected to the signal generator and the standard voltmeter, can be detected on the instrument bandwidth. You can use the two test probes to connect the signal generator and standard voltmeter directly to detect the bandwidth of the instrument and display it on the instrument.

3.5.7.3 Probe Position Setting

Probe setting is to select the test position of leakage current test, select "Probe Setting" in the setup interface, and then select "Probe Setting" in the upper-right corner, the instrument interface will pop up to select the probe options. There are mainly ground to fire, probe to fire and probe to probe, as shown below

Earth Leakage Current

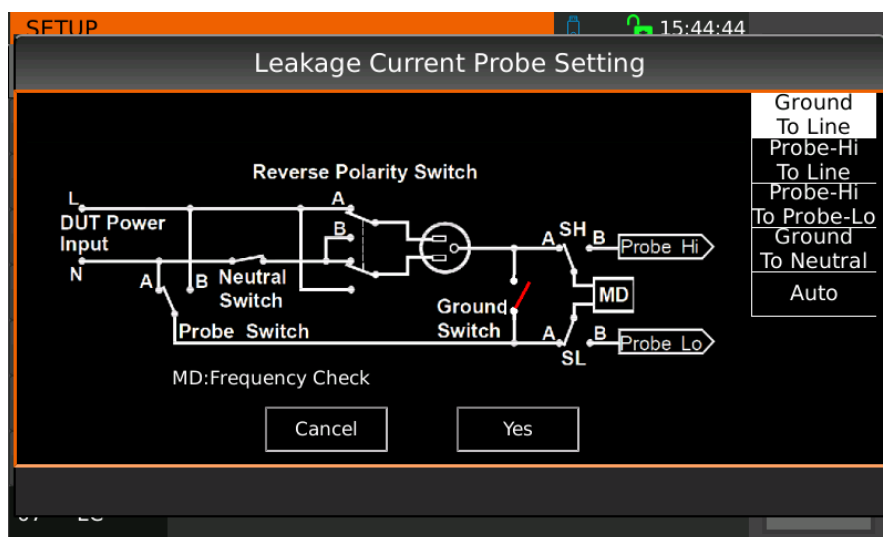

Surface-to-Earth Leakage Current

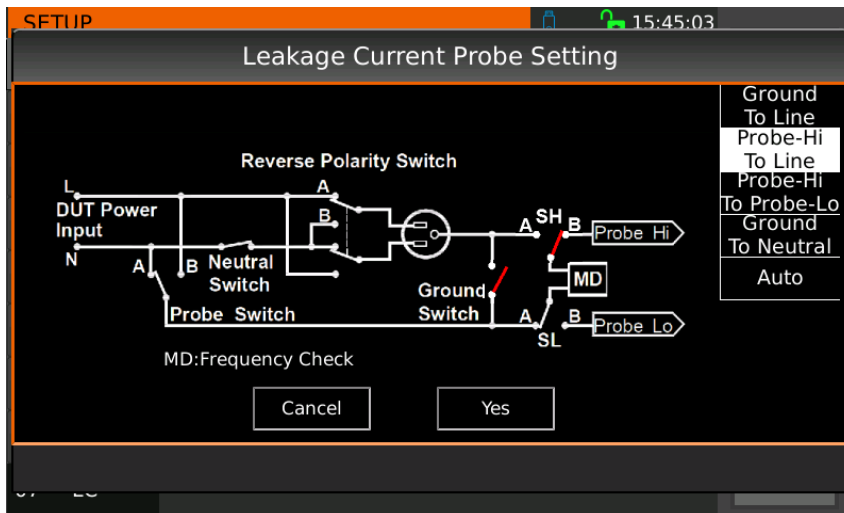

Inter-surface Leakage Current

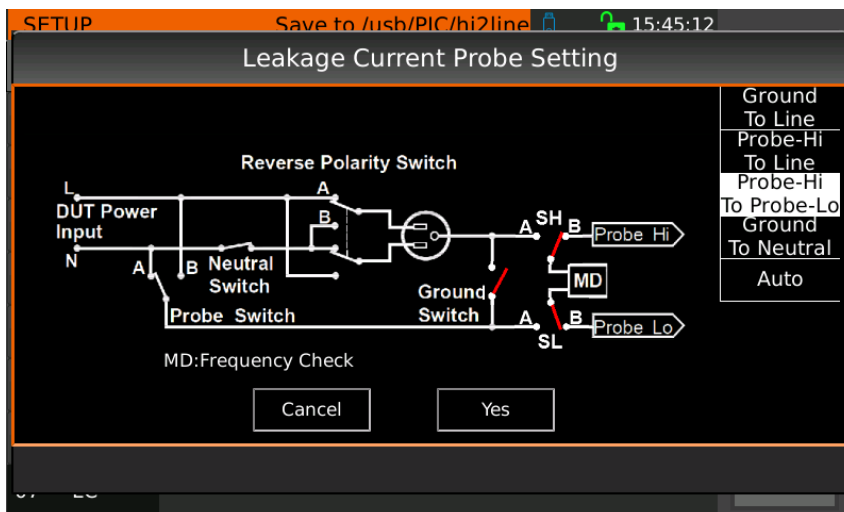

If the **Reverse** polarity switch is set to "Off" and the **Ground** ground switch is set to "Disconnected", the Probe Setup option will add two options, Ground to Zero and Auto, both of which are used to test for leakage current to ground, as shown below. Both options are used to test the leakage current to ground, as shown in the following figure.

Earth Leakage Current

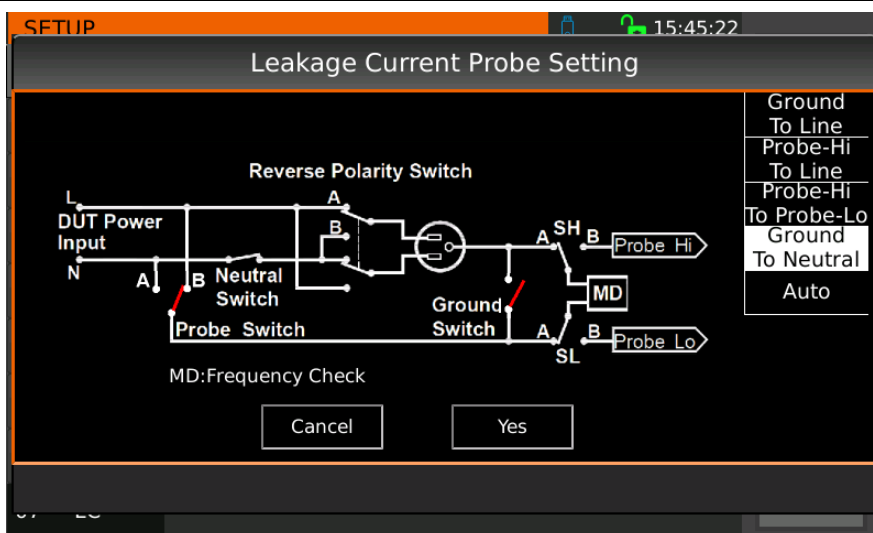

Earth Leakage Current

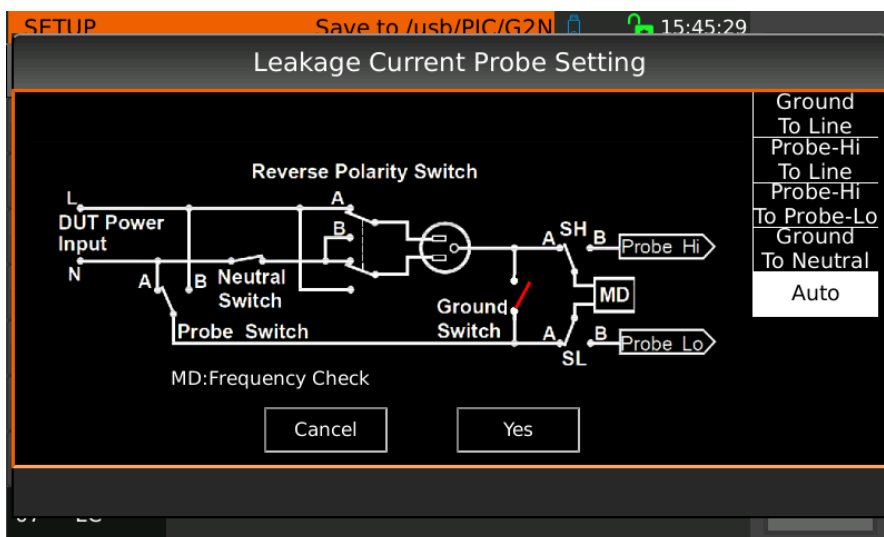

Automatic is measured once each with the Probe Switch switch placed in positions A and B in the diagram above.

Test Probe Position Description Table

Ground To Line	Switch Position				Leakage Current Test
	SH	SL	Probe Switch	Ground Switch	
Earth to Fire Ground To Line	A	A	A	DisconnectOpen/CloseClose selectable	Earth Leakage Current Earth Leakage Current
Probe to Firewire Probe-Hi to Line	B	A	A	DisconnectOpen/CloseClose selectable	Surface-to-Earth Leakage Current Surface to Line Leakage Current
Probe to Probe Probe-Hi to Probe-Lo	B	B	A	DisconnectOpen/CloseClose selectable	Inter-surface leakage current Surface to Surface Leakage Current

*Ground to Zero Ground To Neutral	A	A	B	Settle for Open	Earth Leakage Current Earth Leakage Current
*Automatic AUTO	A	A	Once for A and B	Settle for Open	Earth Leakage Current Ground To Line & Ground To Neutral
Note: The two tests marked with * above require Reverse to be set to OFF and Ground to be set to Open.					
Table 3-19					

Ground To Line for human body impedance simulation circuit (MD) is connected to the ground of the operating power line of the object to be tested and to the neutral of the system, for leakage current to ground testing.

Probe-Hi To Line is a human body impedance analog circuit (MD) that connects one end to the Probe-Hi, which must be connected to the enclosure of the object to be tested, and the other end to the neutral of the system for surface leakage current testing.

Probe-Hi To Probe-Lo is a human body impedance simulation circuit (MD) connected to the terminals of Probe-Hi and Probe-Lo. It is possible to use a probe or a test rod to connect the two test rods of the human body impedance simulation circuit directly to the two test points of the object under test, and to test the leakage current between these two test points as a surface-to-surface leakage current test.

3.5.7.4 Test Properties and Range Settings

Leakage **current value** mode setting: RMS or peak PEAK can be selected, if RMS is selected, it means that the tested leakage current value is the RMS value of the current; if PEAK is selected, it means that the tested leakage current value is the peak value of the current.

Leakage **current waveform** mode setting, i.e. AC/DC setting: AC AC, DC or AC+DC AC+DC can be selected; if AC is selected, it means that the tested leakage current is purely AC value; if DC is selected, it means that the tested leakage current is purely DC value; if AC+DC is selected, it means that the tested leakage current is AC+DC value (composite wave).

Note: If the leakage current value mode is selected as Peak PEAK, the instrument will force the leakage current value mode to change from Peak PAEK to RMS when the leakage current waveform mode is selected as DC DC.

If AC/DC is selected as AC + DC and the range is set to auto range, the minimum wait time is 0.5 seconds.

If AC/DC is selected as AC or DC and the range is set to auto-range, the minimum wait time is 1.8 seconds.

If AC/DC is selected as AC or DC and the range is set to a fixed range, the minimum wait time is 1.3 seconds.

AC Power Supply (only available for TH9130): If AC Power Supply is set to On in the System Setup, there is a setup screen as shown below in the Setup screen of Electrical Test.

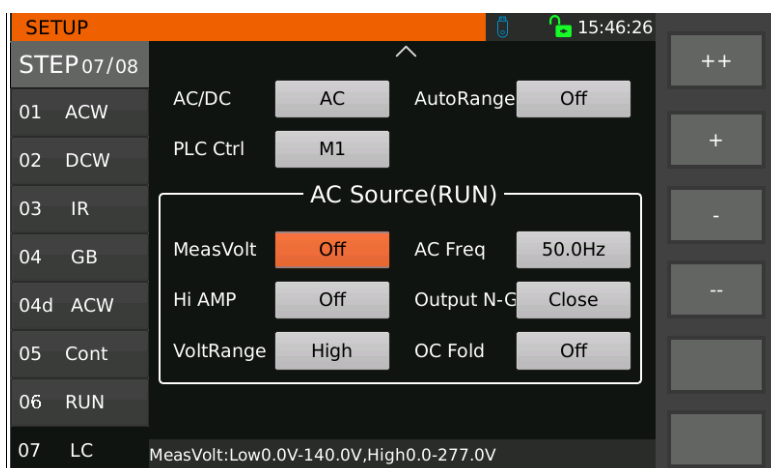

Figure 3-33 AC Power Setup

Setting up the project	Configurable range	Default value	Description
Test voltage	0.0 ~ 277.0V 0.0 ~ 140.0V	Close	Set the test voltage of the AC power supply. Higher/lower voltage ranges correspond to different ranges.
Test Frequency	45.0 ~ 500.0 Hz	50Hz	Set the test frequency of the AC power supply
Upper current limit	0.0 ~ 2.1A 0.0 ~ 4.2A	Close	Set the upper test current limit for the AC power supply. Higher/lower voltage ranges correspond to different ranges.
Zero-line ground	Disconnect/Close	Close	Set whether the zero wire of the AC power supply is grounded.
Voltage range	Upscale/downscale	Upscale	Set the voltage range of the AC power supply.
Overload constant current	Open/Close	Close	If it is set to open, when the output current is greater than the upper current limit setting value, it will continue to output at the set current value (the test voltage will drop) without protection; if it is set to close, when the output current is greater than the upper current limit setting value, the instrument will stop output immediately.

Table 3-20

3.5.8 Open Short Circuit Test Setup

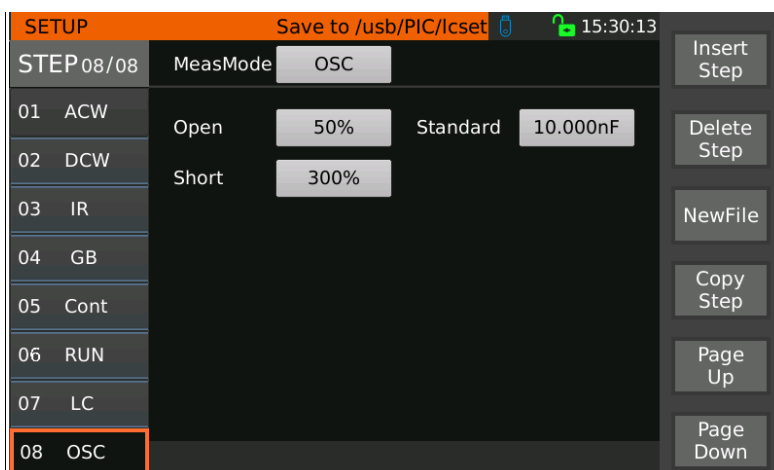

Figure 3-34 Open Short Circuit Test Setup

Setting up the project	Configurable range	Default value	Description
Open Circuit Determination	10% ~ 100%. Step 1%	50%	Set the condition for determining that the test result is an open circuit, expressed as a percentage of the test value to the sampling standard value.
Short Circuit Determination	100% ~ 500% 0 - Closed Step 10%	300%	Set the conditions for determining that the test result is a short circuit, expressed as a percentage of the test value to the sampling standard value. 0 means off, i.e. no short circuit determination.
Sampling criteria	0.001~40nF	10.000nF	To set the standard capacitance value for open-short detection, you can enter a standard value by using the numeric keys, or you can obtain a value as a standard value by sampling.

Table 3-21

Sampling standard: Move the cursor to the sampling standard, as shown in Figure 3-35. You can input the standard value by numeric keys and confirm it by pressing $\llbracket \text{ENTER} \rrbracket$. You can also press $\llbracket \text{sampling} \rrbracket$ key in the figure for sampling. After pressing the sampling key, the instrument enters the standard value sampling state, the instrument outputs 100V AC signal with frequency 600HZ when sampling and obtains the current flowing through the measured part in 1s. (Sampling voltage output, pay attention to safety). The capacitance value displayed by the instrument is not the actual capacitance value, but the value of the sampled current after impedance conversion, which should be approximated with the actual capacitance value installed between the test terminals.

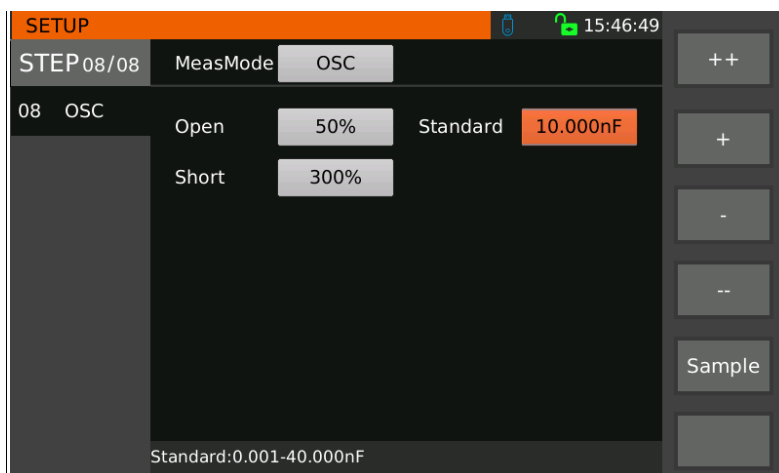

Figure 3-35 Sampling Standard Settings

3.6 Measurement TEST Setting

Operating Instructions:

1. Press [TEST] key to enter the AC measurement interface shown in Figure 3-36.1.
2. Press "Zero" key to clear the zero function, press [▲], [▼] arrow keys or knob or touch the screen directly to display the parameter settings of different test steps as shown in Fig. 3-36.2--Fig. 3-36.8, and press "List Mode" to enter the list display page. Press "List Mode" to enter the list display page.

In the TEST interface you can start the high voltage measurement of the component under test, his test parameters must be set in detail and correctly in the setup interface. After starting the measurement, the main data are displayed in the center of the instrument's display in large fonts. The real-time test data is displayed during the test, and the last test result is displayed after the test is finished without pressing the [STOP] key.

Details are shown in Figures 3-36.1 through 3-36.8 as follows.

The left side of the screen displays the test steps and test functions; the upper center displays the setup parameters related to the test functions; the middle of the screen displays the main test data such as the measured voltage, current, resistance, etc.; the lower center displays the test status and test results; and the right side displays the zeroing and page-turning options.



Figure 3-36.1 AC Withstand Voltage Measurement



Figure 3-36.2 DC Withstand Voltage Measurement



Figure 3-36.3 Insulation Resistance Measurement



Figure 3-36.4 Grounding Resistance Measurement



Figure 3-36.5 Conductivity Test Measurements

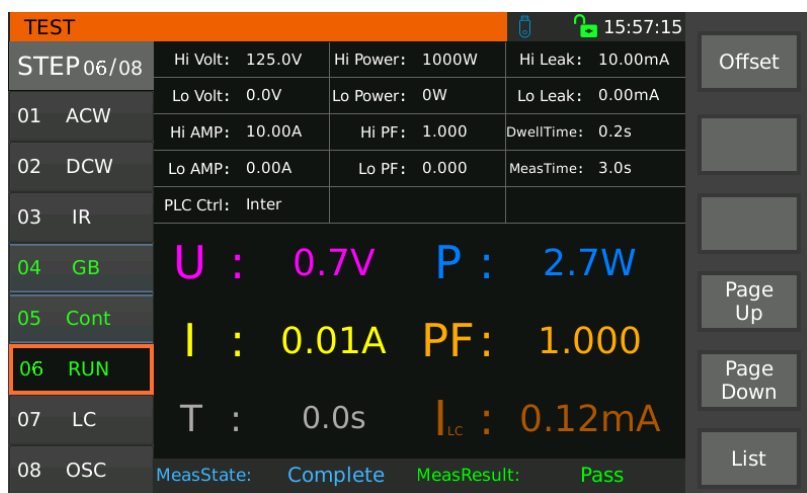

Figure 3-36.6 Electrical Test Measurements

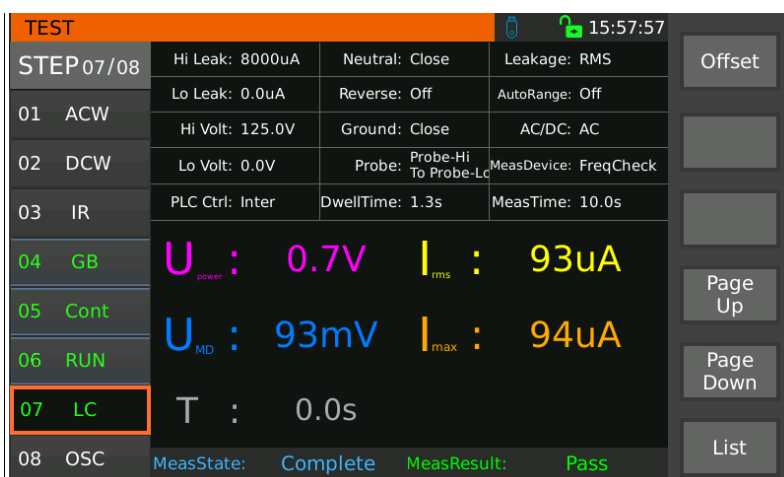

Figure 3-36.7 Leakage Current Measurement (only available for TH9130/TH9131)



Figure 3-36.8 Open/Short Circuit Measurement

3.6.1 Zero

Before the test, due to the instrument working environment and the test cable placement position changes, the instrument no-load test may appear some bottom numbers. For customers who require accurate measurement, you can clear the zero in the TEST measurement interface. The specific operation steps are as follows.

① The object to be tested is first removed from the test line or fixture, and then the SETUP screen is used to set the desired test conditions.

② Press [TEST] key to enter the measurement interface, press "Zero" key, the instrument starts to measure the leakage current of the test line and display the current, taking the current test value as the zero value.

Press the "Zero" key and then press START, the DANGER indicator will flash, and the voltage output time will be 5s.

3.6.2 List Display and Step Display

In addition to the original step display interface, the instrument also has a new list display interface, which can display the parameters of multiple steps, and in the measurement TEST interface, you can press the "list mode" key to enter the list test interface.

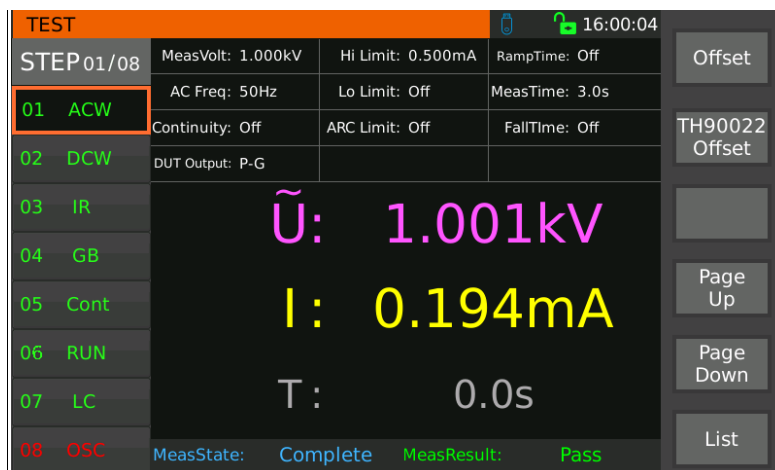

Figure 3-37 Step Display Screen

In the step display page, in addition to the step, test function and other information, at this time it will display the relevant test parameters of the step to be tested that has been set up and completed, as well as the main test data such as the measured voltage, current, resistance, and the test status and test results. As shown in Figure 3-37.

Step	Actual	Limit	Test	Result	Offset
01 ACW	1.001kV	500.0uA	0.194mA	Pass	
02 DCW	1.001kV	500.0uA	191.2uA	Pass	TH90022 Offset
03 IR	1.001kV	1.000MΩ	5.262MΩ	Pass	
04 GB	24.81A	100.0mΩ	4mΩ	Pass	
05 Cont	---	1000.00Ω	0.22Ω	Pass	Page Up
06 RUN	0.7V	10.00A	0.01A	Pass	
07 LC	0.7V	8000.0uA	93.1uA	Pass	Page Down
08 OSC	0.1kV	0.051nF	0.399nF	Short... Fail	

MeasState: Complete AllResult: ----- MeasTime: 0s

Figure 3-38 List Display Interface

In the list display page, the first column shows the test steps and test mode, the second to fourth columns are the test parameters, and the fifth column shows the test results. After pressing [START] to start the test, the test parameters change from setup parameters to test values. As shown in Figure 3-38. Press the "STEP" key to return to the step test interface.

3.7 How to Test

3.7.1 Offset Clearing of Test Leads/Fixtures

- ① First, remove the object to be tested from the test line or fixture and confirm the set test conditions.
- ② Press [TEST] key to enter the measurement interface, press "Zero" key and then press START, the instrument will start to measure the leakage current of the test line and display the current, and take this test value as the zero value.
- ③ After pressing the "Zero" key, the DANGER indicator flashes and the voltage output time is 5s (when the test time is set to be more than 5s), if the test time is less than 5s, the voltage will be output according to the set test time.
- ④ The DANGER lamp stops blinking at the end of clearing.

3.7.2 Sampling Operation of Standard Capacitors

- ① The action of sampling a standard capacitance value, or entering a capacitance value as a standard value, must be performed prior to performing a test in the open short circuit test mode (OSC) or when testing a new capacitance to be tested or replacing a capacitance to be tested.
- ② Before sampling the standard capacitance value, zeroing is performed in the TEST interface. Zeroing must be repeated each time the test leads or fixtures are changed to ensure the accuracy of the test.

③ When sampling a standard capacitance value, first use a standard sample of the capacitance to be tested as the object to be tested, press Sampling in the OSC mode, and measure the capacitance value as the standard value to be used in the test.

④ When testing in the open/short circuit test mode (OSC), the sampled capacitance value is used as the condition for judging OPEN/SHORT.

3.7.3 DUT Connection Method

The steps for connecting the routine tests are described below:

① First confirm that there is no voltage output from the instrument and that the DANGER indicator does not light up or blink.

② Then connect the test line for low potential to the Return terminal of the instrument, short-circuit this test line with the high-end test line, and insert the high voltage test line into the HV terminal of the high voltage output to confirm that there is no high voltage output.

③ Finally, connect the test lead from the low potential Return end to the DUT first, and then connect the test lead from the high potential HV end to the DUT.

④ For ground resistance test, connect the test lead at the RETURN end first, and then connect the test lead at the CURRENT end to the DUT.

For the wiring of the **backplane output** test, here we take a power supply DUT as an example to make a simple instrument wiring example, as shown in the following figure. The L&N terminals on the rear panel of the instrument are connected to the L and N lines of the DUT (AC input), the GND terminal on the rear panel of the instrument is connected to the G line of the DUT, the Case terminal on the rear panel of the instrument is connected to the enclosure or ground terminal of the DUT, and the EXTERNAL terminal of the instrument is connected to the secondary output of the DUT (DC output).

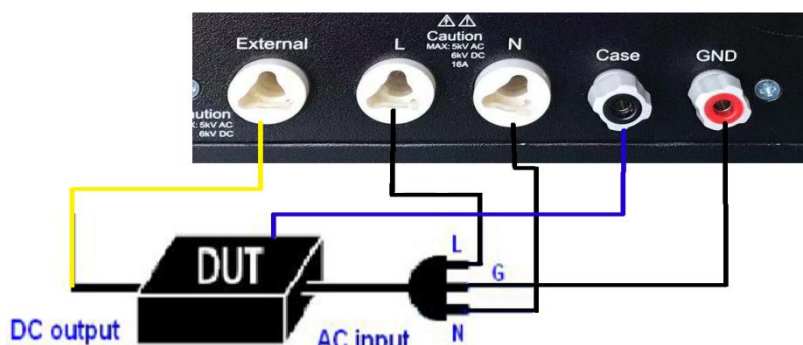

Figure 3-39 Instrument Backplane Wiring Diagram

For wiring using the **TH90022 fixture box** test, as shown in the figure below. Connect the DUT input (AC input) directly to the socket of the TH90022, the EXTERNAL terminal to the DUT's secondary output (DC output), and the Case terminal on the rear panel to the DUT's enclosure.

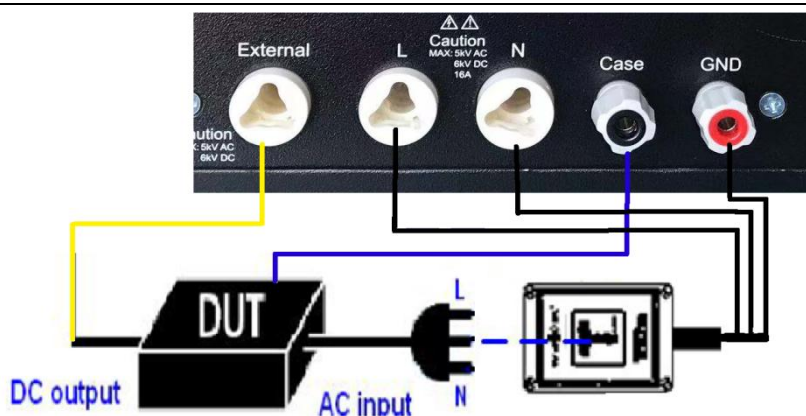

Figure 3-40 TH90022 Wiring Diagrams

For test lead connections for **electrical** and **leakage tests**, refer to the two wiring diagrams above. The input terminal (AC input) of the DUT is connected to the L and N terminals on the rear panel of the instrument or to the socket terminal of the TH90022. The G line end of the DUT is connected to the GND terminal on the rear panel of the instrument.

3.7.4 Test Program

3.7.4.1 Routine Test Procedures

- ① Correctly connect the DUT according to the DUT connection method.

Press [TEST] key to enter the measurement interface, at this time it will display the steps to be tested which have been set up, the left side of the screen displays the test steps and test functions; the upper center displays the setup parameters related to the test functions; the middle part displays the main test data such as measured voltage, current, resistance, etc., and the lower part of the middle is the test status and test results; the right side is the clearing and flipping page option.

- ② Press the [STOP] key to prepare for the test.

Press the [START] key to start the test, when the key is pressed, there will be high voltage or high current output, at this time the DANGER light flashes. **Warning: At this time in the test state, there is a high voltage or high current output!!!!** The screen displays the measured high voltage output value, the measured current value or resistance value, and the corresponding time, and there is an information prompt in the lower left corner.

- ③ Conformity Determination

When all the test states are tested and the lower right corner of the test result shows qualified, the instrument is judged as qualified and cuts off the high-voltage output, and the rear panel also gives the qualified signal, and the buzzer operates at the same time.

- ④ Failure to pass judgment

If abnormal test value is detected, the instrument will be judged as unqualified, and the output will be cut off immediately. The back panel gives the unqualified signal, the buzzer moves at the same time, and continues to move until the instrument presses the [STOP] key. The lower right corner of the test result is unqualified.

In any case, to abort the test output just press the [STOP] key.

3.7.4.2 OSC Test Program

- ① Correctly connect the DUT according to the DUT connection method

Press [TEST] key to enter into the measurement interface, then it will display the steps to be tested which have been set up, including test steps, test functions, and the percentage of open-circuit and short-circuit judgment, and the test voltage, capacitance value and time.

- ② Press the [STOP] key to prepare for the test

Press the [START] key to start the test, when this key is pressed, there will be a high voltage output, at this time the DANGER lamp flashes. The measured high voltage output value, the measured capacitance value and the corresponding time are displayed, and there is an information prompt in the lower left corner.

- ③ Conformity Determination

When all the test states are tested and the lower right corner of the test result shows qualified, the instrument is judged as qualified and cuts off the high-voltage output, and the rear panel also gives the qualified signal, and the buzzer operates at the same time.

- ④ Failure to pass judgment

If abnormal test value is detected, the instrument will be judged as unqualified, and the output will be cut off immediately. The back panel gives the unqualified signal, the buzzer moves at the same time, and continues to move until the instrument presses the [STOP] key. The lower right corner of the test result is unqualified.

Failure Description Form:

Test Results Show	Implied Meaning
Bad OPEN circuit	Capacitance open capacitance test value and sampling standard percentage is less than the percentage of open judgment setting
Bad SHORT circuit	Capacitance short circuit capacitance test value and sampling standard percentage is greater than the short circuit judgment setting percentage

Table 3-22

In any case, to abort the test output just press the [STOP] key.

Example: Take 3-coil inductor for example: the capacitance between 1-2 is about 300P, the capacitance between 1-3 is about 200P, and the capacitance between 2-3 may be short-circuited. First confirm the value of the open circuit, not connected to the measured parts, sampling: $C_s = 100P$; then confirm the standard value, repeatedly connected to the measured parts to record the sampling data range: $C_s = 350P \sim 450P$; and finally confirm the value of the short-circuit, short-circuit 2-3, repeatedly sampling data range: $C_s = 550P \sim 650P$.

Parameter setting calculation.

Assume that Cs = 400P;

OPEN value: Lower limit $100P/400P=25\%$, upper limit $350P/400P=88\%$, 60% recommended.

SHORT value: Lower limit $450P/400P=112\%$, upper limit $550P/400P=138\%$, 125% is recommended.

3.8 File Storage

Operating Instructions:

1, press [FILE] key, enter the file management interface, as shown in Figure 3-41.

2、Through [▲], [▼] key, knob or direct touch to move the cursor to realize the selection of internal file Files and external file usb, as shown in Figure 4-41.

3, through the [OK] key or touch the screen to the file you want to set up the project, through the F1 ~ F6 keys can be the corresponding operation, as shown in Figure 3-43 and 3-44.

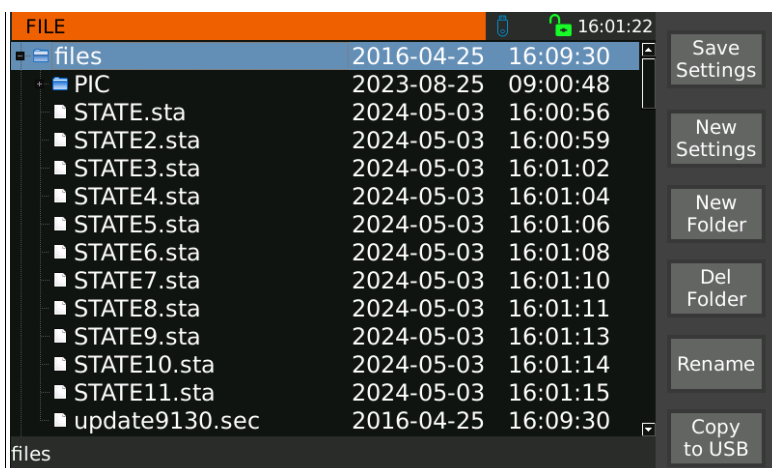

Figure 3-41 Internal Folder Interface

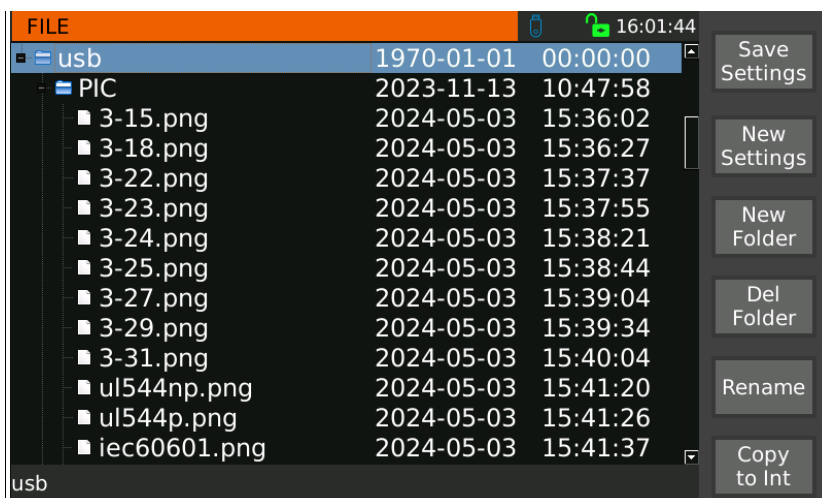

Figure 3-42 External Folder Interface

Functionality	Description
New Folder	Create a new folder
Delete Folder	Delete the currently selected folder
Rename	Rename the currently selected file or folder
Save to internal	Store the current file inside the instrument
Save to USB flash drive	Store the current file on a USB flash drive
Copy to USB flash drive	Copy internal files to a USB flash drive
Copy to internal	Copy files from a USB flash drive into the instrument
Loading file	Load the selected file into the instrument
Delete file	Delete the selected files

Table 3-23

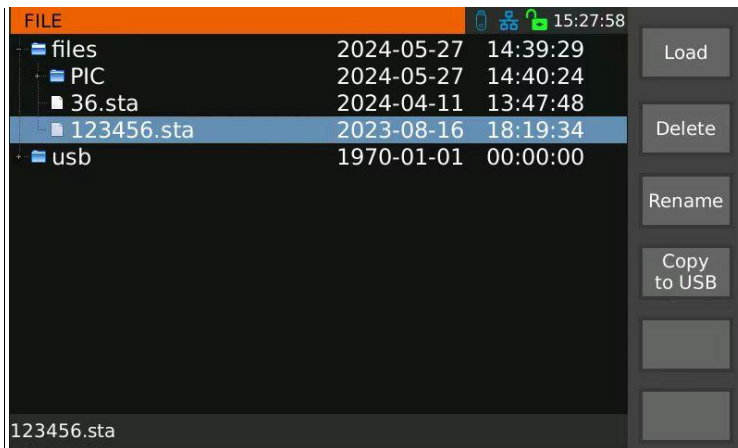

Figure 3-43 Internal File Operation Interface

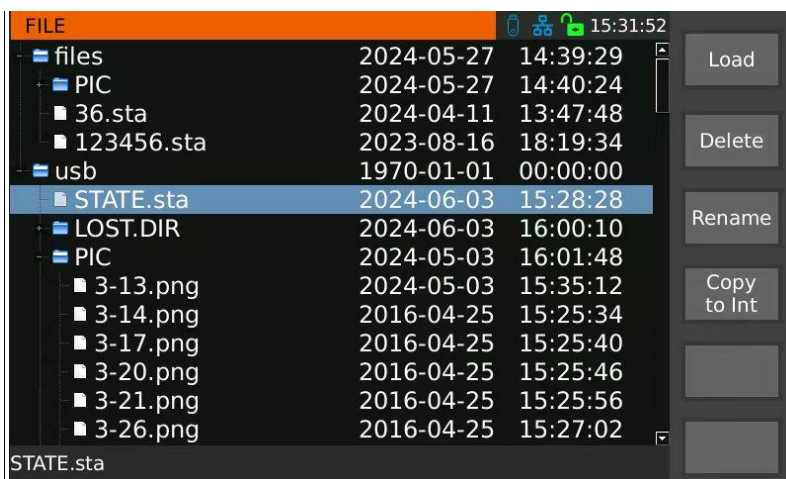

Figure 3-44 External File Operation Interface

3.9 HANDLER

3.9.1 Brief Description of HANDLER

The instrument provides a versatile **HANDLER** interface, which is mainly used for the output of instrument test results. When the instrument is used in an automAted test system, the interface

provides the contact signal with the system and the test result output signal. The signals can be divided into two main categories: internal output signals and external input signals. The internal outputs can be further divided into test result outputs and contact signal outputs. Internal signal output specification: **DC 24V, 20 ~ 40mA**; external signal input specification: **DC 3V ~ 26V (HIGH), 10mA ± 4mA**.

Interface Pin Description:

Pin	Test Function	Signal Name	Causality	Description
2	Open-short circuit	/OPEN	Output	Open-short OPEN output
	Earth resistance	/GR_HIGH		The test result is HIGH FAIL, and the output is LOW
	Conductivity Test	/ConR_HIGH		
	Electrical testing	/RunU_HIGH		
	Leakage test	/LCU_HIGH		
3	Open-short circuit	/SHORT	Output	Open-short SHORT output
	Earth resistance	/GR_LOW		The test result is LOW FAIL, and the output is LOW
	Conductivity Test	/ConR_LOW		
	Electrical testing	/RunU_LOW		
	Leakage test	/LCU_LOW		
4	Common	/FAIL	Output	The output is LOW when the test result is FAIL, then the /HIGH, /LOW, /ARC_FAIL, /GFI_FAIL, and /SHORT_FAIL signals are output (LOW action)
5	Common	/PASS	Output	When the test result is PASS, the output is LOW, and the signals /HIGH, /LOW, /ARC_FAIL, /GFI_FAIL, and /SHORT_FAIL will not be output (all are HIGH).
6	AC withstand voltage	/HIGH	Output	The test current of AC withstand voltage is greater than the upper limit, the test result is HIGH FAIL, and the output is LOW.
	DC withstand voltage			The test current of DC withstand voltage is greater than the upper limit, the test result is HIGH FAIL,

				and the output is LOW.
	Electrical insulation resistance			Insulation resistance test resistance is greater than the upper limit, the test result is HIGH FAIL, the output is LOW.
	Leakage test			Leakage test leakage current is greater than the upper limit, the test result is HIGH FAIL, the output is LOW
7	AC withstand voltage	/LOW	Output	The test current of AC withstand voltage is less than the lower limit, the test result is LOW FAIL, and the output is LOW
	DC withstand voltage			The test current of DC withstand voltage is less than the lower limit, the test result is LOW FAIL, the output is LOW
	Electrical insulation resistance			Insulation resistance of the test resistance is less than the lower limit, the test result is LOW FAIL, the output is LOW
	Leakage test			Leakage test leakage current is less than the lower limit, the test result is LOW FAIL, the output is LOW
15	Electrical testing	/RunI_HIGH	Output	The test current of the electrical test is greater than the upper limit, the test result is HIGH FAIL, and the output is LOW
18	Electrical testing	/RunI_LOW	Output	The test current of the electrical test is less than the lower limit, the test result is LOW FAIL, and the output is LOW
19	Pressure resistance test	/SHORT_FAIL	Output	The test result is SHORT_FAIL and the output is LOW
	Electrical testing	/RunP_HIGH		The test power of the electrical test is greater than the upper limit, the test result is HIGH FAIL, and the output is LOW
	Leakage test	/MD-ULimit		The test voltage of MD is greater than 30VDC, the test result is MD-U Limit, and the output is LOW
20	Pressure resistance	/ARC_FAIL	Output	The test results in ARC_FAIL and the output is LOW

	test			
	Electrical testing	/RunP_LOW		The test power of the electrical test is less than the lower limit, the test result is LOW FAIL, and the output is LOW
21	Pressure resistance test	/GFI_FAIL	Output	The test result is GFI_FAIL and the output is LOW
1	Electrical testing	/RunPF_HIGH	Output	The power factor of the electrical test is greater than the upper limit, the test result is HIGH FAIL, and the output is LOW
14	Electrical testing	/RunPF_LOW	Output	The power factor of the electrical test is less than the lower limit, the test result is LOW FAIL, and the output is LOW
16	Common	/EOT	Output	When this signal is HIGH, it means that the test program is being tested; when this signal is LOW, it means that the test program is finished or in standby.
17	Common	/EOS	Output	When this signal is HIGH, it means that the test step (STEP) is currently being tested; when this signal is LOW, it means that the test step (STEP) has been completed and the next step has not yet been carried out or all test steps have been completed.
13	Common	+24V	Output	Internal DC voltage output
24,25	Common	GND	--	Low voltage terminal of internal voltage output
,23	Common	COM	--	Low voltage terminals of input/output signals
10,11	Common	EXT_DCV	Input	+VEXT: external DC voltage input, input voltage range between +3V and +26V
8	Common	/EXT_STOP	Input	External STOP signal input, action when signal status is LOW
9	Common	/EXT_START	Input	External START signal input, action when signal status is LOW

Table 3-24

3.9.2 External Control Line Legend

3.9.2.1 Example of using the internal power supply

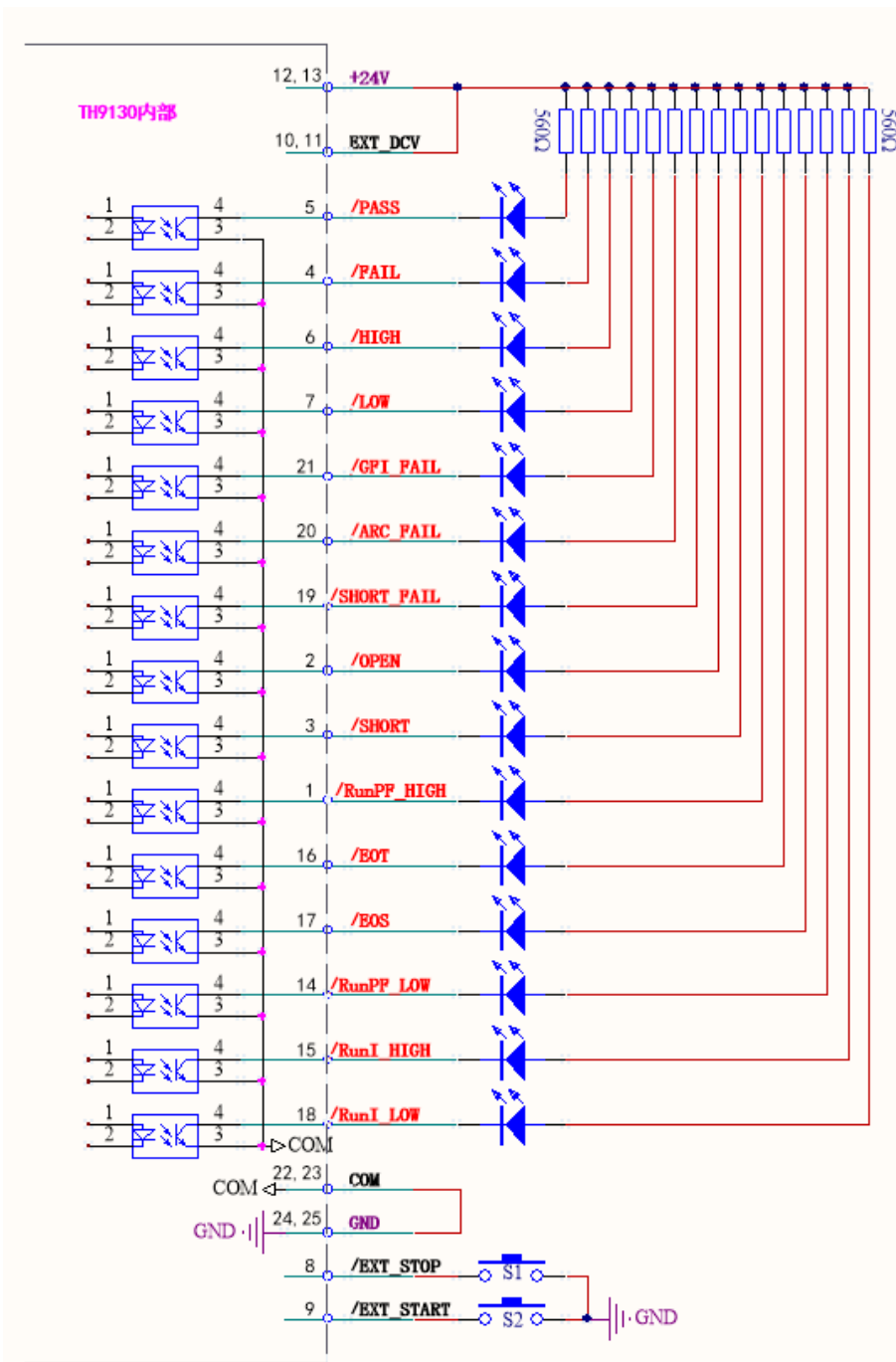

3.9.2.2 Example of using the external power supply

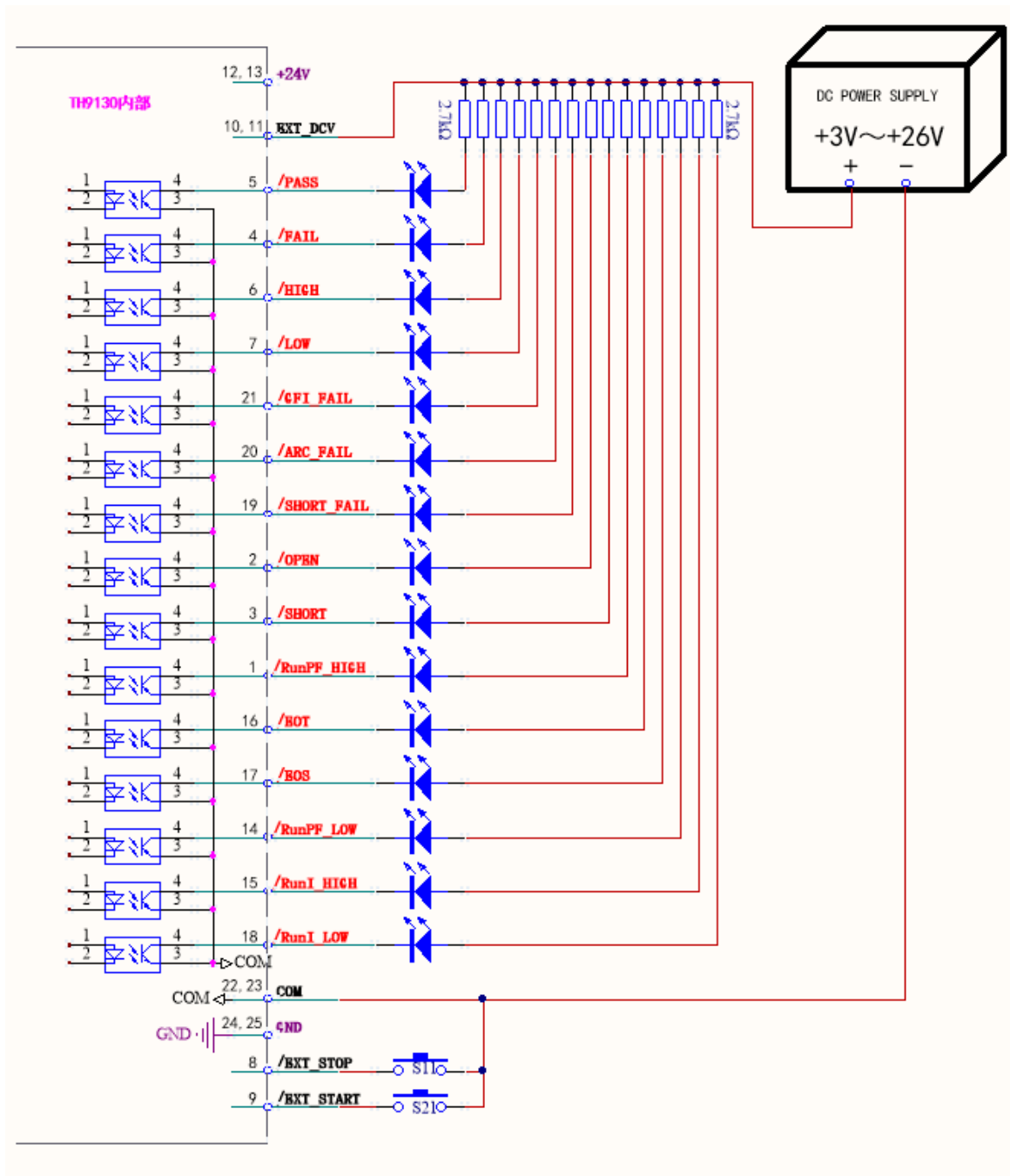

3.9.2.3 Timing Diagram

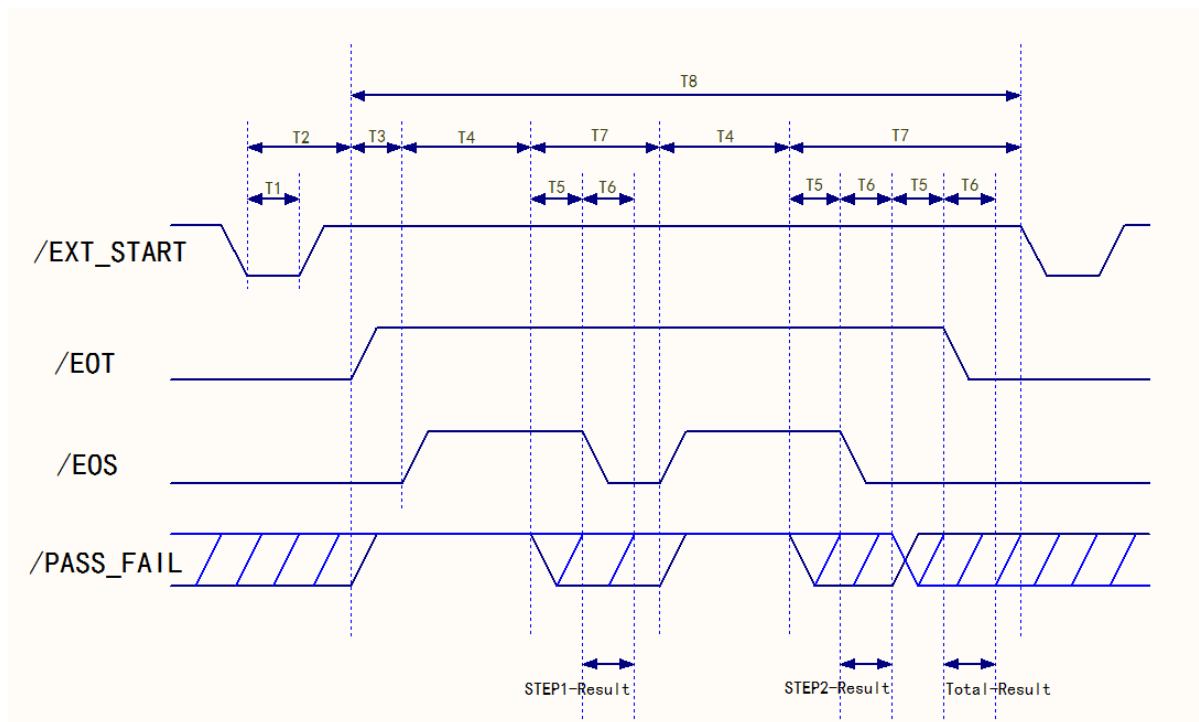

Timing diagram - example of 2 test steps

Time	Range	Explanations
T1	>10mS	External trigger signal(/EXT_STRAT) continue time, need about >10mS
T2	<20mS	External trigger signal(/EXT_STRAT) time needed from start to /EOT signal is cleared, <20mS
T3	-----	Time setup for the trigger delay
T4	-----	Time needed for each test steps (STEP)
T5	>10mS	/PASS_FAIL signals, stable waiting time, >10mS
T6	>10mS	/EOS continue time, result output time or /EOT signal stable waiting time, >10mS
T7	-----	Time needs for each test steps completion
T8	-----	Time needed for the test files (FILE)

Chapter 4 Interfaces and Communications

The instrument can use either the RS232C serial interface (standard) or the GPIB parallel interface (optional) for data communication and remote control without the instrument panel, but they cannot be used at the same time; they have the same programmed Commands but use different hardware configurations and communication protocols. This chapter describes how to use the interface, and the use of interface Commands is detailed in Chapter 4.2.

4.1 Remote Control Interface

4.1.1 RS232C Interface Description

The instrument provides an RS232C interface for communication with a computer. The instrument provides a wealth of program control Commands, through the RS232C interface, the computer can implement the instrument panel almost all the functions of the operation.

4.1.1.1 RS232C Interface Introduction

Currently widely used serial communication standard is the RS-232 standard, can also be called asynchronous serial communication standard, used to realize the computer and the computer, computer and peripheral data communication between the RS for the "Recommended Standard" (Recommended Standard) of the acronym, 232 is the standard number, the standard is the United States Electronic Industries Association (EIA) published in 1969 standard, it provides for one bit at a time by a data line transmission. Standard number, the standard is the U.S. Electronic Industries Association (EIA) in 1969 officially announced the standard, which provides for one bit at a time by a data line transmission.

Most serial port configurations are usually not strictly based on the RS-232 standard: 25-pole connectors are used at each port (9-pole connectors are used for IMB AT). The most commonly used RS-232 signals are shown in the table.

Code	Notation	25 pole connector pin number	9 pole connector pin number
Request To Sent	RTS	4	7
Clear To Send	CTS	5	8
Data Set Ready	DSR	6	6
Data Carrier Detect	DCD	8	1
Data Terminal Ready	DTR	20	4
Transmit Data	TXD	2	3
Receive Data	RXD	3	2
Ground	GND	7	5

As with most serial ports in the world, the instrument's serial interface is not strictly based on the RS-232 standard, but only a minimal subset is provided. The following table.

Code	Notation	Connector Pin Number
Transmit Data	TXD	3
Receive Data	RXD	2
Ground	GND	5

This is the easiest and cheapest way to communicate using the serial port.

①Note: The serial port pin definition of this instrument is basically the same as the pin definition of the connector of a standard 9-cell RS232C.

The RS232C connector on this instrument uses a 9-pole pin DB type socket with the following pinout sequence.

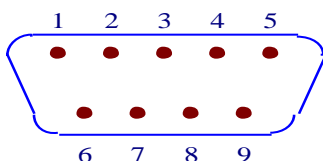

(Viewed from the outside)

Direct connection is possible using a standard DB type 9-pole box plug.

⚠WARNING: To avoid electrical shock, turn off the power when plugging or unplugging the connector.

⚠WARNING: Do not short the output terminals, or short to the chassis to avoid damage to the device.

4.1.1.2 Communication with Computers

The instrument is connected to the computer as shown in the following diagram.

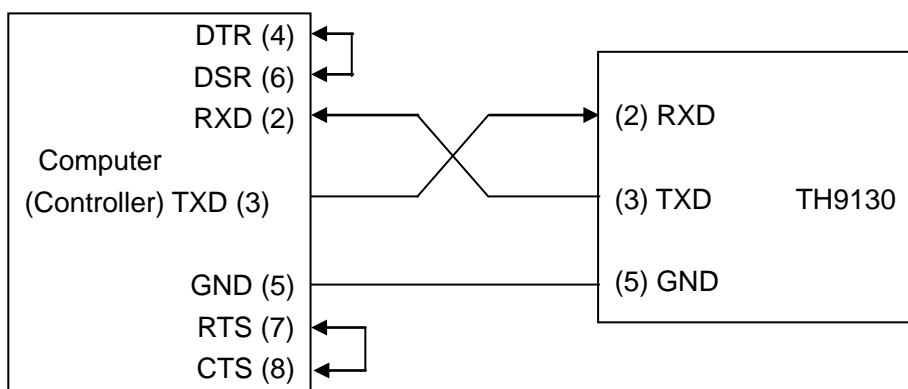

As can be seen from the above figure, the pin definition of this instrument is the same as that of the 9-pole connector serial interface pin definition used by IBM AT-compatible machines. Users can use two-core shielded cable as shown in the diagram to make their own three-wire connection cable (the length should be less than 1.5m) or from the same benefit of the Electronic Co., Ltd. purchased to the serial interface between the computer and the instrument cable or directly buy a standard DB9 core cable (crossover cable).

When making your own connecting cable, note that you should short pins 4 and 6 and pins 7 and 8 on the computer connector.

■ When communicating with the computer through the serial port, the bus mode of the instrument should be set first, and the operation sequence is as follows.

Press the SYSTEM menu key→ (F3 softkey)→ arrow keys to move the cursor to the port type→ RS232C softkey.

■ Serial Port Main Parameters

Transmission method	Full duplex asynchronous communication with start and stop bits
Baud Rate	9600 bps/19200bps/38400bps/115200bps
Data bit	8 BIT or 7 BIT
Stop bit	1 BIT or 2BIT
Calibration	No parity / Odd parity / Even parity
Termination character	NL (newline, ASCII code 10)
Contact details	Software contact
Connectors	DB9 core

■ Software Protocol

Since no hardware communication is used on the RS232 interface, to minimize possible data loss or data errors during communication, the instrument uses character return for software communication. Please refer to the following when preparing the computer communication software.

- (1) The Command string syntax and format are described in Chapter 5.3, "Serial Port Command Set".
- (2) Commands sent by the host are transmitted in ASCII code, with NL (i.e., line feed, ASCII code 10) as the terminator, and the instrument starts executing the Command string after receiving the terminator.
- (3) Whenever the instrument receives a character, it immediately sends the character back to the host, and the host should continue to send the next character after receiving this return character. If the return character is not accepted, the possible factors are
 1. Serial port connection failure.
 2. Check that the instrument has turned on the RS232 port function.
 3. The instrument is executing a bus Command and is temporarily unable to respond to a serial accept. At this point, the last character sent is ignored by the instrument and the host should retransmit the unreturned character if the Command string is to be complete.
- (4) This instrument sends information to the host computer only in the following two cases:

1. Command characters normally received from the host are sent back in that character.
2. Executes the Query command and sends the query result to the host.
- (5) Once the instrument executes the Query command, it will send the query result immediately, regardless of whether the current Command string has been fully executed. Therefore, there can be multiple queries in a Command string, but the host has to read the result operation for a corresponding number of times. This protocol recommends only one query in a Command string.
- (6) The query result is sent as an ASCII string, with NL (i.e. line break, ASCII code 10) as the terminator.
- (7) When the instrument sends the query result, it is sent continuously (about 1ms interval), and the host should be in the state of accepting data, otherwise it may cause data loss.
- (8) After the host generates a query, it should ensure that it reads the empty query result (accepting NL to indicate the end) to avoid conflicts between the query and the return; similarly, the host should read the empty return character before reading the query result.
- (9) For some bus Commands that take a long time to complete, such as clearing zero, the host should actively wait or synchronize the execution of the previous Command by responding to the user's keyboard input confirmation to avoid the next Command being ignored or errors during the Command execution.
- (10) The communication software compiled with DOS application software should be run in a pure DOS environment that supports serial ports. If it is run under WINDOWS, errors may occur due to different management of serial ports.

■ Serial Interface Program Example

The following example is a communication program written in C to run under a pure DOS environment, where the main function can be extended by the user to communicate arbitrarily, and the other sub-functions show how to use the serial port for string input and output.

```
#define PORT 0

#include "dos.h"
#include "stdio.h"
#include "stdlib.h"
#include "ctype.h"
#include "conio.h"

void port_init( int port,unsigned char code );

int check_stat( int port ); /* read serial port state(16bit) */

void send_port( int port,char c ); /* send a character to serial port */
```

```

char read_port( int port ); /* recive a character form serial port */

void string_wr( char *ps ); /* write a string to serial port */

void string_rd( char *ps ); /* read a string from serial port */

char input[256].          /* quAry recieve bufer */

main()

{ port_init( PORT,0xe3 );/* initialize serial port:baud = 9600,no verify,1 bit stop,8 bit data */

    string_wr( "trig:sour bus;*trg" ).

    string_rd( input ).

    printf( "\n%s",input ).

    string_wr( "freq 10khz" ).

    string_wr( "func:imp:type rx;:func:smon on" ).

    string_wr( "voltage:level 500mv" ).

}

/* write string to serial port */

void string_wr( char *ps )

{ char c.

    int m,n.

    while( check_stat(PORT) & 256 ) read_port( PORT );/* read data until null */

    for( ;*ps; )

    { c = 0.

        for( m = 100;m;m-- )

        { send_port( PORT,*ps ).

            for( n = 1000;n;n-- )

            { delay( 2 ); /* wait about 2ms, use dos.h libray funtion */

                if( kbhit() && ( getch() == 27 ) ) /* if escape key keypress */

                { printf( "\nE20:Write Canceled!" );

                    exit(1);

```

```

    }
    if( check_stat(PORT) & 256 )
    { c = read_port( PORT );
      break;
    }
  }
  if( n ) break;
}
if( c == *ps ) ps++;
else
{ printf( "\nE10:Write Echo Error!" );
  exit(1);
}
}

send_port( PORT, '\n' ); /* send Command end symbol */
delay( 2 );
while( ! (check_stat(PORT) & 256) );
read_port( PORT ).
}

/* read string from serial port */
void string_rd( char *ps )
{ unsigned char c,i.
  for( i = 0; i < 255; i++ ) /* max read 256 characters */
  {while( ! (check_stat(PORT) & 256) ) /* wait serial receive ready */
    if( kbhit() && (getch() == 27) ) /* if escape key keypress */
    { printf( "\nE21:Read Canceled!" );
      exit(1);
    }
  }

  c = read_port( PORT );

```

```
    if( c == '\n' ) break;

    *ps = c.

    ps++;

}

*ps = 0.

}

/* send a character to serial port */

void send_port( int port,char c )

{

    union REGS r.

    r.x.dx = port; /* serial port */

    r.h.ah = 1; /* int14 function1:send character */

    r.h.al = c; /* character to be sent */

    int86( 0x14,&r,&r ).

    if( r.h.ah & 128 ) /* check ah.7,if set by int86( 0x14,&r,&r ),mean trans error */

    { printf( "\nE00:Serial port send error!" );

        exit(1);

    }

}

}

/* read a character from serial port */

char read_port( int port )

{ union REGS r; }

    r.x.dx = port; /* serial port */

    r.h.ah = 2; /* int14 function2:read character */

    int86( 0x14,&r,&r ).

    if( r.h.ah & 128 ) /* if ah.7 be set,mean trans error */

    { printf( "\nE01:Serial port read error!" );

        exit(1);

    }

}
```

```
    return r.h.al;
}

/* check the status of serial port */
int check_stat( int port )
{ union REGS r; }
    r.x.dx = port; /* serial port */
    r.h.ah = 3; /* int14 function3:read status */
    int86( 0x14,&r,&r ).
    return r.x.ax; /* ax.7 show serial operation, ax.8 show serial receive ready */

/* initialize the serial port */
void port_init( int port,unsigned char code )
{ union REGS r; }
    r.x.dx = port; /* serial port */
    r.h.ah = 0; /* int14 function0:initial serial port */
    r.h.al = code; /* initialization code */
    int86( 0x14,&r,&r ).
}
```

4.1.2 GPIB Interface Description

4.1.2.1 GPIB Bus

IEEE488 (GPIB) General Parallel Bus Interface is an international standard for intelligent instrument bus interfaces, IEEE is the acronym of the Institute of Electrical and Electronics Engineers, and 488 is the standard number. Through the interface can be connected to the computer or other intelligent equipment to communicate with other test instruments can be easily composed of Automatic test systems. Multiple test instruments can be connected to the same bus at the same time. In this instrument, the instrument adopts IEEE488.2 standard, and the interface board is optional by the user. The control Command system is open, the user can use the computer operation interface provided by the product or can be programmed according to the control Command system to achieve the purpose. The control Command system supports most of the functions of the instrument, that is to say, almost all functions of the instrument can be operated on the control computer to realize the remote control of the instrument.

When using the instrument's GPIB system, the following points should be noted.

The total cable length of a bus system should not exceed the product of 2 meters and the total number of connected test instruments, and the total cable length should not exceed 20 meters.

Up to 15 test instruments can be connected simultaneously on the same bus.

There is no limit to how the cables can be connected together, but it is recommended that only 4 back connectors be stacked on any one test instrument.

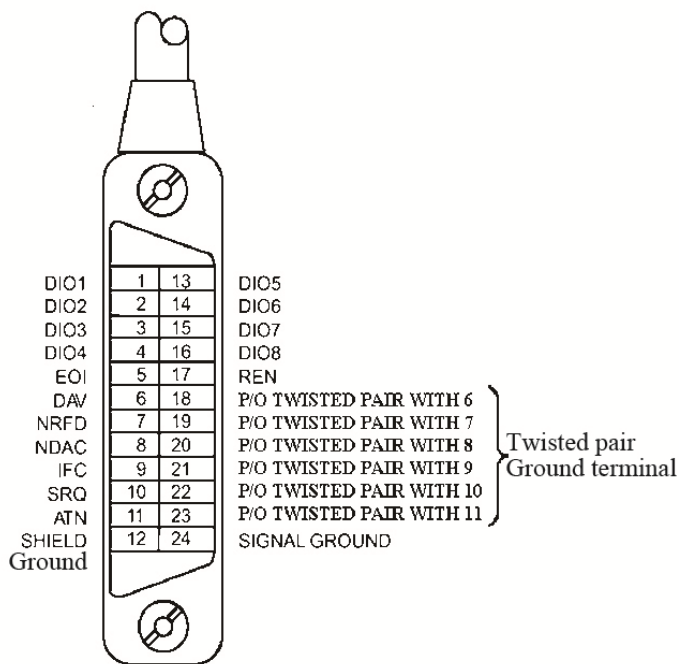

Figure 5-1 GPIB Connector/Pin Structure Diagram

GPIB cable connection method:

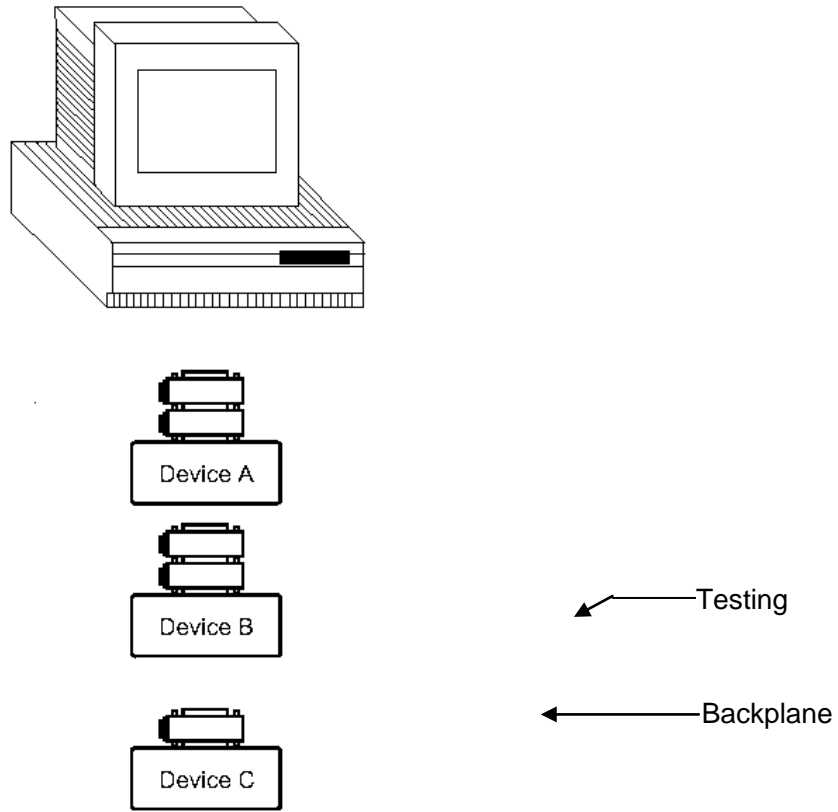

Figure 5-2 DuAl-Backed Connector Stacking

GPIB cable connection method two:

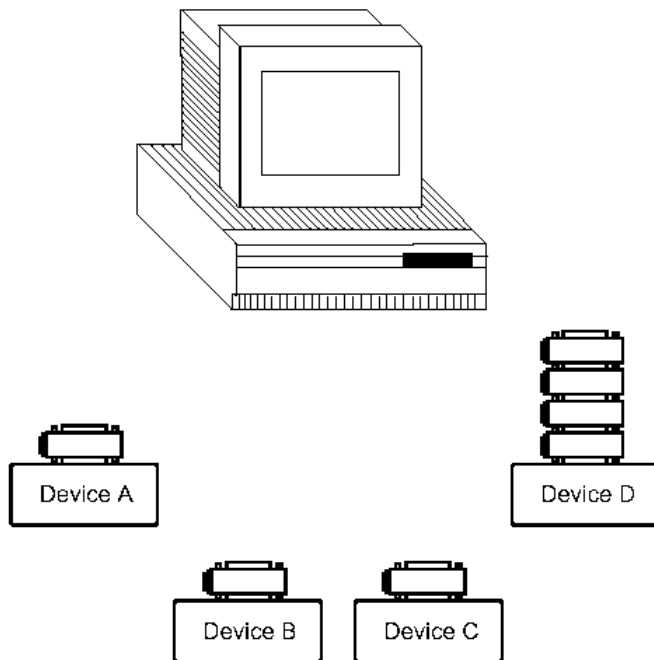

Figure 5-3 QuAd-Back Connector Stacking

4.1.2.2 GPIB Interface Function

The instrument provides most of the general GPIB functions except for the controller, see the following table.

Nicknames	Functionality
SH1	Support all data source contact functions
AH1	Support all fiducial contact functions
T5	Basic Speak Function; Speak Function Only; Speak Cancel at MLA; Serial Roll Call Not Supported
L4	Basic listening function; MTA when listening canceled; no listen-only function
RL1	Remote/Local Functions
DC1	Device Clear Function
DT1	Device Trigger Function
C0	No Controller Function
E1	Open Collector Drive

4.1.2.3 GPIB Address

The GPIB of this instrument is addressed by single address, there is no subaddress, 0-30 can be used as the GPIB address, the factory default address is 1, the address value can be Automatically saved in the non-volatile memory, the address setting is described below.

Press SYSTEM menu key→ (F3 softkey)→ Arrow keys move cursor to port type→ GPIB softkey→ Arrow keys move cursor to address number→ Numeric keypad to enter address

4.1.2.4 GPIB Bus Function

The instrument can respond to the following GPIB bus Commands:

- Interface Clearance (IFC)
- Clearance Device (SDC or DCL)

The instrument will clear the input and output buffers and the GPIB interface is in a ready state after receiving this Command.

- Local Control (GTL)

This Command returns the instrument to local control with the panel keys active.

- Local Lockdown (LLO)

This Command makes all keys on the panel inoperable.

Local blocking can be lifted by executing the "Local Control" Command.

- Remote control (RMT)

4.2 Serial Port Command Set Description

Brief description of the instruction format:

1. The instrument instruction set describes only the actual characters that the instrument accepts or sends.
2. The Command characters are all ASCII characters.
3. The data "<??? >" are ASCII strings. The system default format is integer or floating-point number, the default data unit does not appear in the instruction.
4. Instructions must end with an instruction end marker; the default end marker is.
 - a) NL: Carriage return character, integer 10 (0x0A). An identifier for the end of an instruction, without which the instrument does not parse the instruction.
 - b) ^END: EOI (end of instruction) signal for the IEEE-488 bus.

Multi-Command brief description:

Multi-Command can be categorized into 8 Commands corresponding to 8 main test modes according to the different test functions.

The first digit separated by space after the CAL character indicates the test mode, which includes (0:AC, 1:DC, 2:IR, 3:GB, 4:CONT, 5:RUN, 6:LC, 7:OSC); the subsequent digits or characters correspond to the parameter settings under different test modes respectively.

Note: The "_" in the example is a space marker, and all parameters under different test functions should be written fixedly

1. AC Test Multi-Instruction

Example:

TH9130/TH9131:

FUNC:SUR:STEP_1:CAL_0_1.5_1_0_0_0_1_3_1_0_0(NL^END)

TH9130A/TH9131A:

FUNC:SUR:STEP_1:CAL_0_1.5_1_0_0_0_1_3_1(NL^END)

Numbers and characters separated by spaces after the CAL character indicate, respectively:

Test mode (0:AC, 1:DC, 2:IR, 3:GB, 4:CONT, 5:RUN, 6:LC, 7:OSC);

Test voltage (0.050~5.000kV) Upper limit of current (0.001~100.000mA)

Lower current limit (0 ~ upper limit value) Arc limit (0, 1.0 ~ 20.0mA)

Test frequency (0:50Hz, 1:60Hz) Rise time; test time; fall time;

Conductivity test (0:OFF, 1:ON) (only available for TH9130/TH9131)

Backplane outputs (0:P-G, 1:S-G, 2:P-S) (only available for TH9130/TH9131)

2. DC test multi-Command

Example:

TH9130/TH9131.

FUNC:SOUR:STEP_1:CAL_1_2_0.05_0_0_0_3_0_3_3_0_0_0(NL^END)

TH9130A/TH9131A.

FUNC:SUR:STEP_1:CAL_1_2_0.05_0_0_0_3_0_3_3_0(NL^END)

Numbers and characters separated by spaces after the CAL character indicate, respectively:

Test mode (0:AC, 1:DC, 2:IR, 3:GB, 4:CONT, 5:RUN, 6:LC, 7:OSC);

Test voltage (0.050~6.000kV) Upper current limit (0.0001~20.000mA)

Lower current limit (0~upper limit value) Rising judgment (0:OFF, 1:ON)

Rising arc (1.0 ~ 10.0mA) Arc limit (0, 1.0 - 10.0mA)

Rising time; Waiting time; Testing time; Falling time;

Conductivity test (0:OFF, 1:ON) (only available for TH9130/TH9131)

Backplane outputs (0:P-G, 1:S-G, 2:P-S) (only available for TH9130/TH9131)

3. Insulation Test Multi-Instruction

Example:

TH9130/TH9131:

FUNC:SUR:STEP_1:CAL_2_1.5_0_1000_0_0_0_6_0_0(NL^END)

TH9130A/TH9131A:

FUNC:SUR:STEP_1:CAL_2_1.5_0_1000_0_0_0_6_0(NL^END)

Numbers and characters separated by spaces after the CAL character indicate, respectively:

Test mode (0:AC, 1:DC, 2:IR, 3:GB, 4:CONT, 5:RUN, 6:LC, 7:OSC);

Test voltage (0.050~6.000kV) Resistance upper limit (0, lower limit~50000 MΩ)

Lower resistance limit (0.1~50000 MΩ) Test range (0~6, 0:auto)

Rising time; Delay time; Testing time; Falling time;

Backplane outputs (0:P-G, 1:S-G, 2:P-S) (only available for TH9130/TH9131)

4. Ground Resistance Multi-Instruction

Example: FUNC:SOUR:STEP_1:CAL_3_8_40_150_0_0_3_0_0(NL^END)

Numbers and characters separated by spaces after the CAL character indicate, respectively:

Test mode (0:AC, 1:DC, 2:IR, 3:GB, 4:CONT, 5:RUN, 6:LC, 7:OSC);

Test voltage (3.00~8.00V) Test current (1.00~40.00A)

Resistance upper limit (0 ~ 600mΩ) Lower resistance limit (0 ~ upper limit)

Test frequency (0:50Hz, 1:60Hz) Test Time

Manual zeroing (0-200mΩ) Synchronized output (0:OFF, 1:AC, 2:DC)

5. On-resistance multi-instruction

Example:

TH9130/TH9131.

FUNC:SUR:STEP_1:CAL_4_5000_0_3_0(NL^END)

TH9130A/TH9131A:

FUNC:SUR:STEP_1:CAL_4_5000_0_3(NL^END)

Numbers and characters separated by spaces after the CAL character indicate, respectively:

Test mode (0:AC, 1:DC, 2:IR, 3:GB, 4:CONT, 5:RUN, 6:LC, 7:OSC);

Resistance upper limit (0 ~ 10000Ω) Resistance lower limit (0 ~ upper limit)

Testing time

Conductivity test (0:GND, 1:OFF, 2:L-N) (only available for TH9130/TH9131)

6. Electrical Test Multi-instruction (TH9130/TH9131 available)

Example:

TH9130:

FUNC:SUR:STEP_1:CAL_5_230_40_2_0_500_0_1_0_3_0_5_30_0_220_2_1_50_0_0 (NL^END)

TH9131:

FUNC:SOUR:STEP_1:CAL_5_230_40_2_0_500_0_1_0_3_0_5_30_0(NL^END)

Numbers and characters separated by spaces after the CAL character indicate, respectively:

Test mode (0:AC, 1:DC, 2:IR, 3:GB, 4:CONT, 5:RUN, 6:LC, 7:OSC);

Voltage upper limit (0.0 ~ 277.0V) Lower voltage limit (0 ~ upper limit)

Upper current limit (0.00 ~ 16.00A) Lower current limit (0 ~ upper limit)

Power upper limit (0 ~ 4500W) Lower power limit (0~upper limit)

Upper limit of power factor (0.000 ~ 1.000) Lower limit of power factor (0 ~ upper limit)

Leakage upper limit (0.00 ~ 10.00mA) Lower leakage limit (0 ~ upper limit)

Waiting time; test time remote control (0 to 6)

*Source voltage (0.0 ~ 277.0V) *Source current limit (0 ~ 4.2A)

*Source voltage range (0:LOW, 1:HIGH) *Source frequency (45.0 ~ 500.0Hz)

*Zero wire grounding (0:OFF, 1:ON) *Overload constant current (0:OFF, 1:ON)

Note*: *Indicates that it is only available for TH9130

7. Leak test multi-command (TH9130/TH9131 available)

Example:

TH9130:

FUNC:SUR:STEP_1:CAL_6_230_180_2000_0_5_10_1_0_0_0_0_0_0_1_0_220_2_1_50_0_0 (NL^END)

TH9131:

FUNC:SOUR:STEP_1:CAL_6_230_180_2000_0_5_10_1_0_0_0_0_0_1_0(NL^END)

Numbers and characters separated by spaces after the CAL character indicate, respectively:

Test mode (0:AC, 1:DC, 2:IR, 3:GB, 4:CONT, 5:RUN, 6:LC, 7:OSC);

Voltage upper limit (0.0 ~ 277.0V) Lower voltage limit (0 ~ upper limit)

Leakage upper limit (0.0 ~ 10000uA) Lower leakage limit (0 ~ upper limit)

Waiting time; test time human body network (0 to 9)

Current measurement (0: RMS, 1: PEAK) Zero-line setting (0: closed, 1: open)

Polarity setting (0: closed, 1: open, 2: Automatic) Grounding setting (0: closed, 1: open)

Probe settings 0~4 (0: ground to firewire, 1: probe to firewire, 2: probe to probe, 3: ground to zero, 4: auto) Current waveform (0: AC, 1: DC, 2: AC+DC) Auto range (0:OFF, 1:ON)

Remote control (0 to 6)

*Source voltage (0.0~277.0V) *Source current limit (0~4.2A)

*Source voltage range (0:LOW, 1:HIGH) *Source frequency (45.0 to 500.0Hz)

*Zero wire grounding (0:OFF, 1:ON) *Overload constant current (0:OFF, 1:ON)

Note*: *Indicates that it is only available for TH9130

8. Open and short circuit test multi-Command

Example: FUNC:SOUR:STEP_1:CAL_7_20_300_10(NL^END)

Numbers and characters separated by spaces after the CAL character indicate, respectively:

Test mode (0:AC, 1:DC, 2:IR, 3:GB, 4:CONT, 5:RUN, 6:LC, 7:OSC);

Open circuit ratio (10 ~ 100%) Short circuit ratio (0, 100 ~ 500%)

Sampling capacitance (0.001 ~ 40.000nF)

4.2.1 SCPI Instruction Set

Instrument subsystem Commands for the TH9130

- DISPlay ●FUNCtion ●SYSTEM
- MMEM ●FETC

4.2.2 DISPlay Subsystem Commands Set

The DISPlay subsystem Command is mainly used to set the display page of the instrument.

◆ **DISP:PAGE**

Command syntax: DISP:PAGE <page name>

<page name> is as follows.

TEST	Set display screen to: Measurement display screen (TEST)
SETUP	Set the display screen to: Measurement setting screen (SETUP)
SYST	Set the display screen to: System settings screen (SYST)
FILE	Set the display screen to: File list screen (FILE)

Characters? You can query the current page.

--Example:

Set the display screen to: Measurement display screen.

Setting command: DISP:PAGE TEST

Query command: DISP:PAGE?

Return value: TEST

◆ **DISP:MODE**

Command Syntax: DISP:MODE <mode>

Setting the measurement page display mode: 0, step mode; 1, list mode

--Example:

Set the step mode

Setting command: DISP:MODE 0

Query command: DISP:MODE?

Return value: 0

◆ **DISP:STEP <sn>:OFFSET**

Command Syntax: DISP:STEP <sn>:OFFSET <zero mode>

Setting the measurement page zeroing operation: 0, close zeroing; 1, open zeroing; 2, TH90022 zeroing

--Example.

Set the first step to clear

Setting command: DISP:STEP 1:OFFSET 1

Query command: DISP:STEP 1:OFFSET?

Return value: 1

4.2.3 FUNCTION Subsystem Commands Set

4.2.3.1 FUNCTION Subsystem Commands

The FUNCTION subsystem commands are mainly used to set test parameters for instrument test functions.

4.2.3.2 PROG Function Command Set

FUNC:SOURce:STEP? Query the number of all current test steps.

FUNC:SOURce:STEP_<sn>:INS Adds a new test item within an existing test scenario (STEP).
FUNC:SOURce:STEP_<sn>:DEL Deletes the current test item within an existing test scenario (STEP).

FUNC:SOURce:STEP_<sn>:NEW Creates a new empty test scenario to be used to write a brand new test scenario.

FUNC:SOURce:STEP_<sn>:PRJ Set/query current test mode

--Format:

Setting format: **FUNC:SOUR:STEP <sn>:PRJ <pattern>**

Query format: **FUNC:SOUR:STEP <sn>:PRJ?**

--Data<sn>:

Data type: Integer

Data range: 0~7

Data accuracy: 1

--Data<model>:

Data type: character

Data range: 0(AC), 1(DC), 2(IR), 3(GB), 4(CONT), 5(RUN) (only available for TH9130/TH9131), 6(LC) (only available for TH9130/TH9131), 7(OSC)

--Example:

Set the test mode in STEP 1 to: IR

Setting command: **FUNC:SOUR:STEP 1:PRJ IR**

Query command: **FUNC:SOUR:STEP 1:PRJ?**

Return value: 2 (IR)

4.2.3.3 AC Setup Function Command Set

◆ **FUNC:SOURce:STEP:AC:VOLT** Set/query the voltage of ACW.

--Format:

Setting format: **FUNC:SOUR:STEP <sn>:AC:VOLT<voltage value>**

Query format: **FUNC:SOUR:STEP <sn>:AC:VOLT?**

--Data<sn>:

Data type: Integer

Data range: 1~50

Data accuracy: 1

--Data <voltage value>:

Data type: floating point number

Data range: 0.050~5.000

Data accuracy: 0.001

Data unit: kV

--Example:

Set the voltage of ACW in STEP 1 to: 1kV

Setup command: FUNC:SOUR:STEP 1:AC:VOLT 1.000

Query command: FUNC:SOUR:STEP 1:AC:VOLT?

Return value: 1.000



FUNC:SOURce:STEP:AC:UPPC Set/query the upper limit current of ACW.

--Format:

Setting format: FUNC:SOUR:STEP <sn>:AC:UPPC<current value>

Query format: FUNC:SOUR:STEP <sn>:AC:UPPC?

--Data <current value>:

Data type: floating point number

Data range: 0.001 to 120.000mA (voltage less than 4000V)

0.001 to 100.000mA (Voltage > 4000V)

Data accuracy: 0.001mA

Data unit: mA

--Example:

Set the upper current limit of ACW in STEP 1 to: 1mA

Setting command: FUNC:SOUR:STEP 1:AC:UPPC 1

Query command: FUNC:SOUR:STEP 1:AC:UPPC?

Return value: 1.000



FUNC:SOURce:STEP:AC:LOWC Set/query the lower limit current of ACW

--Format:

Setting format: FUNC:SOUR:STEP <sn>:AC:LOWC <Current

value>

Query format: FUNC:SOUR:STEP <sn>:AC:LOWC?

--Data <current value>:

Data type: floating point number

Data range: 0 to upper limit current value (0 means off)

Data accuracy: 0.001mA

Data unit: mA

--Example:

Set the lower current limit of ACW in STEP 1 to: 1mA

Setting command: FUNC:SOUR:STEP 1:AC:LOWC 1

Query command: FUNC:SOUR:STEP 1:AC:LOWC?

Return value: 1.000



FUNC:SOURce:STEP:AC:TTIM Set/query the ACW test time

--Format:

Setting format: FUNC:SOUR:STEP <sn>:AC:TTIM<time value>

Query format: FUNC:SOUR:STEP <sn>:AC:TTIM?

--Data<time value>:

Data type: floating point number
 Data range: 0, 0.3 to 999.0s (0 means off)
 Data accuracy: 0.1s
 Data unit: s

--Example:

Set the test time for ACW in STEP 1 to: 1s
 Setting command: FUNC:SOUR:STEP 1:AC:TTIM 1
 Query command: FUNC:SOUR:STEP 1:AC:TTIM?
 Return value: 1.0

◆ **FUNC:SOURce:STEP:AC:RTIM** Set/query the rise time of ACW.

--Format:

Setting Format: FUNC:SOUR:STEP <sn>:AC:RTIM <time value>
 Query format: FUNC:SOUR:STEP <sn>:AC:RTIM?

--Data<time value>:

Data type: floating point number
 Data range: 0 to 999.0s (0 means off)
 Data accuracy: 0.1s
 Data unit: s

--Example:

Set the rise time of ACW in STEP 1 to: 1s
 Setting command: FUNC:SOUR:STEP 1:AC:RTIM 1
 Query command: FUNC:SOUR:STEP 1:AC:RTIM?
 Return value: 1.0

◆ **FUNC:SOURce:STEP:AC:FTIM** Set/query ACW fall time

--Format:

Setting Format: FUNC:SOUR:STEP <sn>:AC:FTIM <time value>
 Query format: FUNC:SOUR:STEP <sn>:AC:FTIM?

--Data<time value>:

Data type: floating point number
 Data range: 0 to 999.0s (0 means off)
 Data accuracy: 0.1s
 Data unit: s

--Example:

Set the fall time of ACW in STEP 1 to: 1s
 Setting command: FUNC:SOUR:STEP 1:AC:FTIM 1
 Query command: FUNC:SOUR:STEP 1:AC:FTIM?
 Return value: 1.0

◆ **FUNC:SOURce:STEP:AC:ARC** Set/query the upper limit of ARC current of ACW.

--Format:

Setting format: FUNC:SOUR:STEP <sn>:AC:ARC <current value>
 Query format: FUNC:SOUR:STEP <sn>:AC:ARC?

--Data <current value>:

Data type: floating point number
 Data range: 0, 1.0 to 20.0mA (0 means off)

Data accuracy: 0.1mA

Data unit: mA

--Example:

Set the upper limit of ARC current for ACW in STEP 1 to: 1mA

Setting command: FUNC:SOUR:STEP 1:AC:ARC 1

Query command: FUNC:SOUR:STEP 1:AC:ARC?

Return value: 1.0

◆ **FUNC:SOURce:STEP:AC:FREQ** Set/query the test frequency of ACW.

--Format:

Setting format: FUNC:SOUR:STEP <sn>:AC:FREQ <frequency>

Query format: FUNC:SOUR:STEP <sn>:AC:FREQ?

--Data<frequency>:

Data type: character

Data range: 50/60

Data unit: Hz

--Example.

Set the test frequency of ACW in STEP 1 to: 50Hz

Setting command: FUNC:SOUR:STEP 1:AC:FREQ 50

Query command: FUNC:SOUR:STEP 1:AC:FREQ?

Return value: 50

◆ **FUNC:SOURce:STEP:AC:DUTOUT** Set/query the backplane output status of ACW.

(available only for TH9130/TH9131)

--Format:

Setting format: FUNC:SOUR:STEP <sn>:AC:DUTPUT <state>

Query format: FUNC:SOUR:STEP <sn>:AC: DUTPUT?

--Data<status>:

Data type: character

Data range: 0 to 2 (0:P-G, 1:S-G, 2:P-S)

--Example.

Set the backplane output of ACW in STEP 1 to: P-G

Setting command: FUNC:SOUR:STEP 1:AC:DUTOUT 0

Query command: FUNC:SOUR:STEP 1:AC:DUTOUT?

Return value: 0

◆ **FUNC:SOURce:STEP:AC:CONTI** Set/query the ACW conductivity test status.

(available only for TH9130/TH9131)

--Format:

Setting format: FUNC:SOUR:STEP <sn>:AC:CONTI <state>

Query format: FUNC:SOUR:STEP <sn>:AC: CONTI?

--Data<status>:

Data type: character

Data range: OFF (0), ON (1)

--Example.

Set ACW conductivity test in STEP 1 to: off

Setting command: FUNC:SOUR:STEP 1:AC: CONTI 0

Query command: FUNC:SOUR:STEP 1:AC:CONTI?

Return value: 0

4.2.3.4 DC Setup Function Command Set

- ◆ **FUNC:SOURce:STEP:DC:VOLT** Set/query the voltage of DCW.
 - Format :
 - Setting format: FUNC:SOUR:STEP <sn>:DC:VOLT <voltage value>
 - Query format: FUNC:SOUR:STEP <sn>:DC:VOLT?
 - Data<sn>:
 - Data type: Integer
 - Data range: 1~50
 - Data accuracy: 1
 - Data <voltage value>:
 - Data type: floating point number
 - Data range: 0.050~6.000
 - Data accuracy: 0.001
 - Data unit: kV
 - Example:
 - Set the voltage of DCW in STEP 1 to: 1kV
 - Setting command: FUNC:SOUR:STEP 1:DC:VOLT 1.000
 - Query command: FUNC:SOUR:STEP 1:DC:VOLT?
 - Return value: 1.000

- ◆ **FUNC:SOURce:STEP:DC:UPPC** Set/query the upper limit current of DCW.
 - Format:
 - Setting format: FUNC:SOUR:STEP <sn>:DC:UPPC <Current Value>
 - Query format: FUNC:SOUR:STEP <sn>:DC:UPPC?
 - Data <current value>:
 - Data type: floating point number
 - Data range: 0.0001 to 25.000mA (voltage greater than or equal to 1500V)
 - 0.0001 to 20.000mA (Voltage less than 1500V)
 - Data accuracy: 0.0001mA
 - Data unit: mA
 - Example:
 - Set the upper current limit of DCW in STEP 1 to: 1mA
 - Setting command: FUNC:SOUR:STEP 1:DC:UPPC 1
 - Query command: FUNC:SOUR:STEP 1:DC:UPPC?
 - Return value: 1.0000

- ◆ **FUNC:SOURce:STEP:DC:LOWC** Set/query the lower limit current of DCW.
 - Format:
 - Setting Format: FUNC:SOUR:STEP <sn>:DC:LOWC <current value>
 - Query format: FUNC:SOUR:STEP <sn>:DC:LOWC?
 - Data <current value>:

Data type: floating point number
 Data range: 0 to upper limit current value (0 means off)
 Data accuracy: 0.0001mA
 Data unit: mA
 --Example:
 Set the lower current limit of DCW in STEP 1 to: 1mA
 Setting command: FUNC:SOUR:STEP 1:DC:LOWC 1
 Query command: FUNC:SOUR:STEP 1:DC:LOWC?
 Return value: 1.0000

◆ **FUNC:SOURce:STEP:DC:TTIM** Set/query the DCW test time

--Format:
 Setting format: FUNC:SOUR:STEP <sn>:DC:TTIM <Time value>
 Query format: FUNC:SOUR:STEP <sn>:DC:TTIM?
 --Data<time value>:
 Data type: floating point number
 Data range: 0, 0.3 to 999.0s (0 means off)
 Data accuracy: 0.1s
 Data unit: s
 --Example:
 Set the test time for DCW in STEP 1 to: 1s
 Setting command: FUNC:SOUR:STEP 1:DC:TTIM 1
 Query command: FUNC:SOUR:STEP 1:DC:TTIM?
 Return value: 1.0

◆ **FUNC:SOURce:STEP:DC:RTIM** Set/query the DCW rise time.

--Format:
 Setting Format: FUNC:SOUR:STEP <sn>:DC:RTIM <time value>
 Query format: FUNC:SOUR:STEP <sn>:DC:RTIM?
 --Data<time value>:
 Data type: floating point number
 Data range: 0 to 999.0s (0 means off)
 Data accuracy: 0.1s
 Data unit: s
 --Example:
 Set the rise time of DCW in STEP 1 to: 1s
 Setting command: FUNC:SOUR:STEP 1:DC:RTIM 1
 Query command: FUNC:SOUR:STEP 1:DC:RTIM?
 Return value: 1.0

◆ **FUNC:SOURce:STEP:DC:FTIM** Set/query DCW fall time

--Format:
 Setting Format: FUNC:SOUR:STEP <sn>:DC:FTIM <time value>
 Query format: FUNC:SOUR:STEP <sn>:DC:FTIM?
 --Data<time value>:
 Data type: floating point number
 Data range: 0 to 999.0s (0 means off)
 Data accuracy: 0.1s

Data unit: s

--Example:

Set the DCW fall time in STEP 1 to: 1s

Setting command: FUNC:SOUR:STEP 1:DC:FTIM 1

Query command: FUNC:SOUR:STEP 1:DC:FTIM?

Return value: 1.0

◆ **FUNC:SOURce:STEP:DC:WTIM** Set/query the DCW wait time.

--Format:

Setting Format: FUNC:SOUR:STEP <sn>:DC:WTIM <time value>

Query format: FUNC:SOUR:STEP <sn>:DC:WTIM?

--Data<time value>:

Data type: floating point number

Data range: 0 to 999.0s (0 means off)

Data accuracy: 0.1s

Data unit: s

--Example:

Set the wait time for DCW in STEP 1 to: 1s

Setting command: FUNC:SOUR:STEP 1:DC:WTIM 1

Query command: FUNC:SOUR:STEP 1:DC:WTIM?

Return value: 1.0

◆ **FUNC:SOURce:STEP:DC:ARC** Set/query the upper limit of ARC current of DCW

--Format:

Setting format: FUNC:SOUR:STEP <sn>:DC:ARC <current value

Query format: FUNC:SOUR:STEP <sn>:DC:ARC?

--Data <current value>:

Data type: floating point number

Data range: 0, 1.0 to 10.0mA (0 means off)

Data accuracy: 0.1mA

Data unit: mA

--Example:

Set the upper limit of ARC current for DCW in STEP 1 to: 1mA

Setting command: FUNC:SOUR:STEP 1:DC:ARC 1

Query command: FUNC:SOUR:STEP 1:DC:ARC?

Return value: 1.0

◆ **FUNC:SOURce:STEP:DC:RAMPARC** Set/query the rising arc of DCW.

--Format:

Setting format: FUNC:SOUR:STEP <sn>:DC:RAMPARC <Current

Value

Query format: FUNC:SOUR:STEP <sn>:DC:RAMPARC?

--Data <current value>:

Data type: floating point number

Data range: 0, 1.0 to 10.0mA (0 means off)

Data accuracy: 0.1mA

Data unit: mA

--Example:

Set the rising arc of DCW in STEP 1 to: 1mA

Setting command: FUNC:SOUR:STEP 1: DC:RAMPARC 1

Query command: FUNC:SOUR:STEP 1:DC:RAMPARC?

Return value: 1.0

◆ **FUNC:SOURce:STEP:DC:RAMP** Set/query the status of DCW rising judgment

--Format:

Set the format:

FUNC:SOUR:STEP <sn>:DC:RAMP <ON/OFF>or<1/0>

Query format: FUNC:SOUR:STEP <sn>:DC:RAMP:?

--data<status>:

Data type: character

Data range: OFF (0), ON (1)

--Example:

Set the rising judgment of DCW in STEP 1 to: ON

Setting command: FUNC:SOUR:STEP 1:DC:RAMP ON

Query command: FUNC:SOUR:STEP 1:DC:RAMP?

Return value: 1

◆ **FUNC:SOURce:STEP:DC:DUTOUT** Set/query the backplane output status of DCW.

(available only for TH9130/TH9131)

--Format:

Setting format: FUNC:SOUR:STEP <sn>:DC:DUTPUT <state>

Query format: FUNC:SOUR:STEP <sn>:DC: DUTPUT?

--data<status>:

Data type: character

Data range: 0 to 2 (0:P-G, 1:S-G, 2:P-S)

--Example.

Set the backplane output of the DCW in STEP 1 to: p-s

Setting command: FUNC:SOUR:STEP 1:DC:DUTOUT 2

Query command: FUNC:SOUR:STEP 1:DC:DUTOUT?

Return value: 2

◆ **FUNC:SOURce:STEP:DC:CONTI** Set/query the DCW conduction test status

(available only for TH9130/TH9131)

--Format:

Set the format:

FUNC:SOUR:STEP <sn>:DC:CONTI <ON/OFF>or<1/0>

Query format: FUNC:SOUR:STEP <sn>:DC: CONTI?

--data<status>:

Data type: character

Data range: OFF (0), ON (1)

--Example.

Set the DCW conductivity test in STEP 1 to: OFF

Setting command: FUNC:SOUR:STEP 1:DC: CONTI 0

Query command: FUNC:SOUR:STEP 1:DC: CONTI?

Return value: 0

4.2.3.5 IR Setup Function Command Set

- ◆ **FUNC:SOURce:STEP:IR:VOLT** Set/query the voltage of IR.
 - Format:
 - Setting format: FUNC:SOUR:STEP <sn>:IR:VOLT <voltage value>
 - Query format: FUNC:SOUR:STEP <sn>:IR:VOLT?
 - Data <voltage value>:
 - Data type: floating point number
 - Data range: 0.050~6.000
 - Data accuracy: 0.001
 - Data unit: kV
 - Example:
 - Set the voltage of IR in STEP 1 to: 1kV
 - Setting command: FUNC:SOUR:STEP 1:IR:VOLT 1.000
 - Query command: FUNC:SOUR:STEP 1:IR:VOLT?
 - Return value: 1.000

- ◆ **FUNC:SOURce:STEP:IR:UPPR** Set/query the upper limit of IR resistance.
 - Format:
 - Setting format: FUNC:SOUR:STEP <sn>:IR:UPPR <resistor value>
 - Query format: FUNC:SOUR:STEP <sn>:IR:UPPR?
 - Data <resistance value>:
 - Data type: floating point number
 - Data range: 0, lower limit ~50.0GΩ (0 means off)
 - Data accuracy: 0.001MΩ
 - Data unit: MΩ
 - Example:
 - Set the upper resistance limit of IR in STEP 1 to 1MΩ.
 - Setting command: FUNC:SOUR:STEP 1:IR:UPPR 1
 - Query instruction: FUNC:SOUR:STEP 1:IR:UPPR?
 - Return value: 1

- ◆ **FUNC:SOURce:STEP:IR:LOWR** Set/query the lower resistance limit of IR.
 - Format:
 - Setting format: FUNC:SOUR:STEP <sn>:IR:LOWR <resistance value>
 - Query format: FUNC:SOUR:STEP <sn>:IR:LOWR?
 - Data <resistance value>:
 - Data type: floating point number
 - Data range: 0.05MΩ ~50.0GΩ
 - Data accuracy: 0.001MΩ
 - Data unit: MΩ
 - Example:
 - Set the lower resistance limit of IR in STEP 1 to: 1MΩ
 - Setting command: FUNC:SOUR:STEP 1:IR:LOWR 1
 - Query command: FUNC:SOUR:STEP 1:IR:LOWR?

Return value: 1

- ◆ **FUNC:SOURce:STEP:IR:TTIM** Set/query the test time of IR.
 - Format:
 - Setting format: FUNC:SOUR:STEP <sn>:IR:TTIM <Time value>
 - Query format: FUNC:SOUR:STEP <sn>:IR:TTIM?
 - Data<time value>:
 - Data type: floating point number
 - Data range: 0, 0.3 to 999.0s (0 indicates continuous testing)
 - Data accuracy: 0.1s
 - Data unit: s
 - Example:
 - Set the test time for IR in STEP 1 to: 1s
 - Setting command: FUNC:SOUR:STEP 1:IR:TTIM 1
 - Query command: FUNC:SOUR:STEP 1:IR:TTIM?
 - Return value: 1.0

- ◆ **FUNC:SOURce:STEP:IR:RTIM** Set/query the rise time of IR.
 - Format:
 - Setting Format: FUNC:SOUR:STEP <sn>:IR:RTIM <time value>
 - Query format: FUNC:SOUR:STEP <sn>:IR:RTIM?
 - Data<time value>:
 - Data type: floating point number
 - Data range: 0 to 999.0s (0 means off)
 - Data accuracy: 0.1s
 - Data unit: s
 - Example:
 - Set the rise time of IR in STEP 1 to: 1s
 - Setting command: FUNC:SOUR:STEP 1:IR:RTIM 1
 - Query command: FUNC:SOUR:STEP 1:IR:RTIM?
 - Return value: 1.0

- ◆ **FUNC:SOURce:STEP:IR:WTIM** Set/query IR delay time.
 - Format:
 - Setting Format: FUNC:SOUR:STEP <sn>:IR:WTIM <time value>
 - Query format: FUNC:SOUR:STEP <sn>:IR:WTIM?
 - Data<time value>:
 - Data type: floating point number
 - Data range: 0 to 999.0s (0 means off)
 - Data accuracy: 0.1s
 - Data unit: s
 - Example:
 - Set the delay time of IR in STEP 1 to: 1s
 - Setting command: FUNC:SOUR:STEP 1:IR:WTIM 1
 - Query command: FUNC:SOUR:STEP 1:IR:WTIM?
 - Return value: 1.0

- ◆ **FUNC:SOURce:STEP:IR:FTIM** Set/query the IR fall time.

--Format:
 Setting Format: FUNC:SOUR:STEP <sn>:IR:FTIM <time value>
 Query format: FUNC:SOUR:STEP <sn>:IR:FTIM?
 --Data<time value>:
 Data type: floating point number
 Data range: 0 to 999.0s (0 means off)
 Data accuracy: 0.1s
 Data unit: s
 --Example:
 Set the fall time of IR in STEP 1 to: 1s
 Setting command: FUNC:SOUR:STEP 1:IR:FTIM 1
 Query command: FUNC:SOUR:STEP 1:IR:FTIM?
 Return value: 1.0

◆ **FUNC:SOURce:STEP:IR:RANG** Set/query the range of IR.

--Format:
 Setting format: FUNC:SOUR:STEP <sn>:IR:RANG <Range Value
 Query format: FUNC:SOUR:STEP <sn>:IR:RANG?
 --Data <range value>:
 Data type: integer
 Data range: 0 to 6 (0 means auto, 1 is 10mA, 2 is 3mA, 3 is 300uA,
 4 is 30uA, 5 is 3uA, 6 is 300nA)
 --Example:
 Set the range of IR in STEP 1 to 10mA.
 Setting command: FUNC:SOUR:STEP 1:IR:RANG 1
 Query command: FUNC:SOUR:STEP 1:IR:RANG?
 Return value: 1 (10mA)

◆ **FUNC:SOURce:STEP:IR:DUTOUT** Set/query the backplane output status of IR.

(available only for TH9130/TH9131)

--Format:
 Setting format: FUNC:SOUR:STEP <sn>:DC:DUTPUT <state>
 Query format: FUNC:SOUR:STEP <sn>:DC:DUTPUT?
 --Data<status>:
 Data type: character
 Data range: 0 to 2 (0:P-G, 1:S-G, 2:P-S)
 --Example.
 Set the backplane output of the DCW in STEP 1 to: p-s
 Setting command: FUNC:SOUR:STEP 1:DC:DUTOUT 2
 Query command: FUNC:SOUR:STEP 1:DC:DUTOUT?
 Return value: 2

4.2.3.6 GB Setup Function Command Set

◆ **FUNC:SOURce:STEP:GB:CURRent** Set/query the current of GB.

--Format:

- Setting format: FUNC:SOUR:STEP <sn>:GB:CURR <Current Value>
- Query format: FUNC:SOUR:STEP <sn>:GB:CURR?
- Data <current value>:
 Data type: floating point number
 Data range: 1.00~40.00
 Data accuracy: 0.01
 Data unit: A
- Example:
 Set the current of GB in STEP 1 to: 25A
 Setup Command: FUNC:SOUR:STEP 1:GB:CURR 25.00
 Query command: FUNC:SOUR:STEP 1:GB:CURR?
 Return value: 25.00
- ◆ **FUNC:SOURce:STEP:GB:VOLT** Set/query the voltage of GB.
- Format:
 Setting format: FUNC:SOUR:STEP <sn>:GB:VOLT <Voltage value>
- Query format: FUNC:SOUR:STEP <sn>:GB:VOLT?
- Data <voltage value>:
 Data type: floating point number
 Data range: 3.00~8.00
 Data accuracy: 0.01
 Data unit: V
- Example:
 Set the voltage of GB in STEP 1 to: 5V
 Setting command: FUNC:SOUR:STEP 1:GB:VOLT 5.00
 Query command: FUNC:SOUR:STEP 1:GB:VOLT?
 Return value: 5.00
- ◆ **FUNC:SOURce:STEP:GB:UPPR** Set/query the upper resistance limit of GB.
- Format:
 Setting format: FUNC:SOUR:STEP <sn>:GB:UPPR <resistance>
 Query format: FUNC:SOUR:STEP <sn>:GB:UPPR?
- Data <resistance value>:
 Data type: integer
 Data range: 0~600
 Data accuracy: 1
 Data unit: mΩ
- Example:
 Set the upper resistance limit of GB in STEP 1 to: 150mΩ
 Setting command: FUNC:SOUR:STEP 1:GB:UPPR 150
 Query command: FUNC:SOUR:STEP 1:GB:UPPR?
 Return value: 150
- ◆ **FUNC:SOURce:STEP:GB:LOWR** Set/query the lower limit of resistance of GB
- Format:
 Setting Format: FUNC:SOUR:STEP <sn>:GB:LOWR <resistance

value

Query format: FUNC:SOUR:STEP <sn>:GB:LOWR?
 --Data <resistance value>:
 Data type: integer
 Data range: 0 to upper limit value
 Data accuracy: 1
 Data unit: mΩ
 --Example:
 Set the lower resistance limit of GB in STEP 1 to: 10mΩ
 Setting command: FUNC:SOUR:STEP 1:GB:LOWR 10
 Query command: FUNC:SOUR:STEP 1:GB:LOWR?
 Return value: 10



FUNC:SOURce:STEP:GB:TTIM Set/query the test time of GB.

--Format:
 Setting Format: FUNC:SOUR:STEP <sn>:GB:TTIM <time value>
 Query format: FUNC:SOUR:STEP <sn>: GB: TTIM?
 --Data<time value>:
 Data type: floating point number
 Data range: 0, 0.5 to 999.9s (0 indicates continuous)
 Data accuracy: 0.1s
 Data unit: s
 --Example:
 Set the duration of GB state in STEP 1 to: 1s
 Setting command: FUNC:SOUR:STEP 1:GB:TTIM 1
 Query command: FUNC:SOUR:STEP 1:GB:TTIM?
 Return value: 1.0



FUNC:SOURce:STEP:GB:FREQ Set/query the test frequency of GB.

--Format:
 Setting format: FUNC:SOUR:STEP <sn>:GB:FREQ <frequency>
 Query format: FUNC:SOUR:STEP <sn>:GB:FREQ?
 --Data<frequency>:
 Data type: character
 Data range: 50/60
 Data unit: Hz
 --Example.
 Set the test frequency of GB in STEP 1 to: 50Hz
 Setting command: FUNC:SOUR:STEP 1:GB:FREQ 50
 Query command: FUNC:SOUR:STEP 1:GB:FREQ?
 Return value: 50



FUNC:SOURce:STEP:GB:DUAL Set/query the synchronization test status of GB.

--Format:
 Setting format: FUNC:SOUR:STEP <sn>:GB:DUAL <state>
 Query format: FUNC:SOUR:STEP <sn>:GB:DUAL?
 --Data<status>:

Data type: character
 Data range: 0 to 2 (0:OFF, 1:AC, 2:DC)

--Example.
 Set the synchronization test for GB in STEP 1 to: OFF
 Setting command: FUNC:SOUR:STEP 1:GB:DUAL 0
 Query command: FUNC:SOUR:STEP 1:GB:DUAL?
 Return value: 0

- ◆ **FUNC:SOURce:STEP:GB:OFFSET** Set/query the compensation setting value of GB.

--Format:
 Setting format: FUNC:SOUR:STEP <sn>:GB:OFFSET <state>
 Query format: FUNC:SOUR:STEP <sn>:GB: OFFSET?
 --Data<status>:
 Data type: character
 Data range: 0 to 200mΩ
 --Example.
 Set the compensation setting value of GB in STEP 1 to 5mΩ
 Setting command: FUNC:SOUR:STEP 1:GB: OFFSET 5
 Query command: FUNC:SOUR:STEP 1:GB: OFFSET?
 Return value: 5

4.2.3.7 CONT Setup Function Command Set

- ◆ **FUNC:SOURce:STEP:CONT:UPPR** Set/query the upper limit of resistance of CONT.

--Format:
 Setting format: FUNC:SOUR:STEP <sn>:CONT:UPPR
 <resistance value>
 Query format: FUNC:SOUR:STEP <sn>:CONT:UPPR?
 --Data <resistance value>:
 Data type: floating point number
 Data range: 0.00~10000.00
 Data accuracy: 0.01
 Data unit: Ω
 --Example:
 Set the upper resistance limit of CONT in STEP 1 to: 100Ω
 Setting command: FUNC:SOUR:STEP 1:CONT:UPPR 100.00
 Query command: FUNC:SOUR:STEP 1:CONT:UPPR?
 Return value: 100.00

- ◆ **FUNC:SOURce:STEP:CONT:LOWR** Set/query the lower resistance limit of CONT.

--Format:
 Setting format: FUNC:SOUR:STEP <sn>:CONT:LOWR
 <resistance value>
 Query format: FUNC:SOUR:STEP <sn>:CONT:LOWR?

--Data <resistance value>:
 Data type: integer
 Data range: 0 to upper limit value
 Data accuracy: 1
 Data unit: Ω
 --Example:
 Set the lower resistance limit of CONT in STEP 1 to: 10 Ω
 Setting command: FUNC:SOUR:STEP 1:CONT:LOWR 10.00
 Query command: FUNC:SOUR:STEP 1:CONT:LOWR?
 Return value: 10.00

◆ **FUNC:SOURce:STEP:CONT:TTIM** Set/query the test time of CONT.

--Format:
 Setting format: FUNC:SOUR:STEP <sn>:CONT:TTIM <Time Value>

Query format: FUNC:SOUR:STEP <sn>:CONT:TTIM?
 --Data<time value>:
 Data type: floating point number
 Data range: 0, 0.5 to 999.9s (0 indicates continuous)
 Data accuracy: 0.1s
 Data unit: s
 --Example:
 Set the test time of CONT state in STEP 1 to: 1s
 Setting command: FUNC:SOUR:STEP 1:CONT:TTIM 1
 Query command: FUNC:SOUR:STEP 1:CONT:TTIM?
 Return value: 1.0

◆ **FUNC:SOURce:STEP:CONT:CONTI** Set/query the conduction test status of CONT.

(available only for TH9130/TH9131)

--Format:
 Setting format: FUNC:SOUR:STEP <sn>:CONT:CONTI <state>
 Query format: FUNC:SOUR:STEP <sn>:CONT:CONTI?
 --Data<status>:
 Data type: character
 Data range: 0 to 2 (0:GND, 1:OFF, 2:L-N)
 --Example:
 Set the conduction of CONT in STEP 1 to: GND
 Setting command: FUNC:SOUR:STEP 1:CONT:CONTI 0
 Query command: FUNC:SOUR:STEP 1:CONT:CONTI?
 Return value: 0

4.2.3.8 OSC Setup Function Command Set

◆ **FUNC:SOURce:STEP:OSC:OPEN** Set/query the OPEN ratio of OSC.

--Format:
 Setting format: FUNC:SOUR:STEP <sn>:OSC:OPEN <Ratio>

Query format: FUNC:SOUR:STEP <sn>:OSC:OPEN?

--Data <ratio>:

Data type: Integer

Data range: 10 to 100

Data accuracy: 10

--Example:

Set the OPEN ratio of the OSC in STEP 1 to: 50%

Setting command: FUNC:SOUR:STEP 1: OSC:OPEN 50

Query command: FUNC:SOUR:STEP 1:OSC:OPEN?

Return value: 50

◆ **FUNC:SOURce:STEP:OSC:SHOT** Set/query the SHOT ratio of OSC.

--Format:

Setting format: FUNC:SOUR:STEP <sn>:OSC:SHOT <rate>

Query format: FUNC:SOUR:STEP <sn>:OSC:SHOT?

--Data <ratio>:

Data type: Integer

Data range: 0, 100 to 500 (0 means off)

Data accuracy: 10

--Example:

Set the SHOT ratio of OSC in STEP 1 to: 100%

Setting command: FUNC:SOUR:STEP 1:OSC:SHOT 100

Query command: FUNC:SOUR:STEP 1:OSC:SHOT?

Return value: 100

◆ **FUNC:SOURce:STEP:OSC:GET** Get the capacitance value.

--Format:

Setting format: FUNC:SOUR:STEP <sn>:OSC:GET

The instrument will Automatically sample the current after impedance conversion to capacitance standard value.

◆ **FUNC:SOURce:STEP:OSC:STAND** Set/query the capacitance standard value of OSC.

--Format:

Setting format: FUNC:SOUR:STEP <sn>:OSC:STAND
<capacitance standard value>

Query format: FUNC:SOUR:STEP <sn>:OSC:STAND?

--Data <capacitance standard value>:

Data type: floating point

Data range: 0.001 to 40.000

Data accuracy: 0.001

Data unit: nF

--Example:

Set the standard value of capacitance of OSC in STEP 1 to: 10nF

Setting command: FUNC:SOUR:STEP 1:OSC:STAND 10

Query command: FUNC:SOUR:STEP 1:OSC:STAND?

Return value: 10.000

4.2.3.9 RUN Setup Function Command Set (available only for

TH9130/TH9131)

- ◆ **FUNC:SOURce:STEP:RUN:UPPV** Set/query the upper limit of voltage for RUN.

value

--Format:

Setting format: FUNC:SOUR:STEP <sn>:RUN:UPPV <voltage

Query format: FUNC:SOUR:STEP <sn>:RUN:UPPV?

--Data <voltage value>:

Data type: floating point number

Data range: 0.0~277.0

Data accuracy: 0.1

Data unit: V

--Example:

Set the upper voltage limit of RUN in STEP 1 to: 250V

Setting command: FUNC:SOUR:STEP 1:RUN:UPPV 250.0

Query command: FUNC:SOUR:STEP 1:RUN:UPPV?

Return value: 250.0

- ◆ **FUNC:SOURce:STEP:RUN:LOWV** Set/query the lower limit of voltage for RUN.

value

--Format:

Setting format: FUNC:SOUR:STEP <sn>:RUN:LOWV <voltage

Query format: FUNC:SOUR:STEP <sn>:RUN:LOWV?

--Data <voltage value>:

Data type: floating point number

Data range: 0.0 to upper limit

Data accuracy: 0.1

Data unit: V

--Example:

Set the lower voltage limit of RUN in STEP 1 to: 50V

Setting command: FUNC:SOUR:STEP 1:RUN:LOWV 50.0

Query command: FUNC:SOUR:STEP 1:RUN:LOWV?

Return value: 50.0

- ◆ **FUNC:SOURce:STEP:RUN:UPPC** Set/query the current limit of RUN.

value>

--Format:

Setting Format: FUNC:SOUR:STEP <sn>:RUN:UPPC <current

Query format: FUNC:SOUR:STEP <sn>:RUN:UPPC?

--Data <current value>:

Data type: floating point number

Data range: 0.00~16.00

Data accuracy: 0.01

Data unit: A

--Example:

Set the upper current limit of RUN in STEP 1 to 10A.

Setting command: FUNC:SOUR:STEP 1:RUN:UPPC 10.00

Query command: FUNC:SOUR:STEP 1:RUN:UPPC?

Return value: 10.00



FUNC:SOURce:STEP:RUN:LOWC Set/query the lower current limit of RUN.

--Format:

Setting Format: FUNC:SOUR:STEP <sn>:RUN:LOWC <current

value>

Query format: FUNC:SOUR:STEP <sn>:RUN:LOWC?

--Data <current value>:

Data type: floating point number

Data range: 0.00 to upper limit

Data accuracy: 0.01

Data unit: A

--Example:

Set the lower current limit of RUN in STEP 1 to: 5A

Setting command: FUNC:SOUR:STEP 1:RUN:LOWC 5.00

Query command: FUNC:SOUR:STEP 1:RUN:LOWC?

Return value: 5.00



FUNC:SOURce:STEP:RUN:UPPP Set/query the upper power limit of RUN

--Format:

Setting format: FUNC:SOUR:STEP <sn>:RUN:UPPP <Power

value>

Query format: FUNC:SOUR:STEP <sn>:RUN:UPPP?

--Data <power value>:

Data type: integer

Data range: 0~4500

Data accuracy: 1

Data unit: W

--Example:

Set the power limit of RUN in STEP 1 to: 1000W

Setting command: FUNC:SOUR:STEP 1:RUN:UPPP 1000

Query command: FUNC:SOUR:STEP 1:RUN:UPPP?

Return value: 1000



FUNC:SOURce:STEP:RUN:LOWP Set/query the lower power limit of RUN.

--Format:

Setting Format: FUNC:SOUR:STEP <sn>:RUN:LOWP <power

value>

Query format: FUNC:SOUR:STEP <sn>:RUN:LOWP?

--Data <power value>:

Data type: integer

Data range: 0 to upper limit

Data accuracy: 1

Data unit: W

--Example:

Set the lower power limit for RUN in STEP 1 to: 5W
 Setting command: FUNC:SOUR:STEP 1:RUN:LOWP 5
 Query command: FUNC:SOUR:STEP 1:RUN:LOWP?
 Return value: 5

◆ **FUNC:SOURce:STEP:RUN:UPPF** Set/query the upper limit of power factor of RUN

Factor Value
 --Format:
 Setting format: FUNC:SOUR:STEP <sn>:RUN:UPPF <Power

Query format: FUNC:SOUR:STEP <sn>:RUN:UPPF?

--Data <power factor value>:
 Data type: floating point number
 Data range: 0.000~1.000
 Data accuracy: 0.001

--Example:
 Set the upper power factor limit for RUN in STEP 1 to: 1.000
 Setting command: FUNC:SOUR:STEP 1:RUN:UPPF 1.000
 Query command: FUNC:SOUR:STEP 1:RUN:UPPF?
 Return value: 1.000

◆ **FUNC:SOURce:STEP:RUN:LOWF** Set/query the lower limit of power factor for RUN.

factor value>
 --Format:
 Setting format: FUNC:SOUR:STEP <sn>:RUN:LOWF <Power

Query format: FUNC:SOUR:STEP <sn>:RUN:LOWF?

--Data <power factor value>:
 Data type: floating point number
 Data range: 0.000 ~ upper limit
 Data accuracy: 0.001

--Example:
 Set the lower power factor limit for RUN in STEP 1 to: 0.700
 Setting command: FUNC:SOUR:STEP 1:RUN:LOWF 0.700
 Query command: FUNC:SOUR:STEP 1:RUN:LOWF?
 Return value: 0.700

◆ **FUNC:SOURce:STEP:RUN:UPPL** Set/query the upper limit of leakage current for RUN.

current value
 --Format:
 Setting format: FUNC:SOUR:STEP <sn>:RUN:UPPL <leakage

Query format: FUNC:SOUR:STEP <sn>:RUN:UPPL?

--Data <leakage current value>:
 Data type: floating point number
 Data range: 0.00~10.00, 0 means off

Data accuracy: 0.01

Data unit: mA

--Example:

Set the upper limit of leakage current of RUN in STEP 1 to 3mA.

Setting command: FUNC:SOUR:STEP 1:RUN:UPPL 3.00

Query command: FUNC:SOUR:STEP 1:RUN:UPPL?

Return value: 3.00

- ◆ **FUNC:SOURce:STEP:RUN:LOWL** Set/query the lower limit of leakage current of RUN.

--Format:

Setting format: FUNC:SOUR:STEP <sn>:RUN:LOWL <Leakage

current value>

Query format: FUNC:SOUR:STEP <sn>:RUN:LOWL?

--Data <leakage current value>:

Data type: floating point number

Data range: 0.00 to upper limit

Data accuracy: 0.01

Data unit: mA

--Example:

Set the lower limit of leakage current of RUN in STEP 1 to 0.1mA.

Setting command: FUNC:SOUR:STEP 1:RUN:LOWL 0.10

Query command: FUNC:SOUR:STEP 1:RUN:LOWL?

Return value: 0.10

- ◆ **FUNC:SOURce:STEP:RUN:TTIM** Set/query the test time for RUN.

--Format:

Setting Format: FUNC:SOUR:STEP <sn>:RUN:TTIM <time value>

Query format: FUNC:SOUR:STEP <sn>:RUN:TTIM?

--Data<time value>:

Data type: floating point number

Data range: 0, 0.1 to 999.9s (0 means off)

Data accuracy: 0.1s

Data unit: s

--Example:

Set the test time of RUN in STEP 1 to: 1s

Setting command: FUNC:SOUR:STEP 1:RUN:TTIM 1

Query command: FUNC:SOUR:STEP 1:RUN:TTIM?

Return value: 1.0

- ◆ **FUNC:SOURce:STEP:RUN:WTIM** Set/query the wait time for RUN.

--Format:

Setting Format: FUNC:SOUR:STEP <sn>:RUN:WTIM <time

value>

Query format: FUNC:SOUR:STEP <sn>:RUN:WTIM?

--Data<time value>:

Data type: floating point number

Data range: 0.2 to 999.9s

Data accuracy: 0.1s

Data unit: s

--Example:

Set the wait time for RUN in STEP 1 to: 1s

Setting command: FUNC:SOUR:STEP 1:RUN:WTIM 1

Query command: FUNC:SOUR:STEP 1:RUN:WTIM?

Return value: 1.0



FUNC:SOURce:STEP:RUN:PLC Set/query remote control settings for RUN.

--Format:

Setting format: FUNC:SOUR:STEP <sn>:RUN:PLC <state>

Query format: FUNC:SOUR:STEP <sn>:RUN:PLC?

--Data<status>:

Data type: character

Data range: 0 to 6 (0: memory group 1, 1: memory group 2, 2: memory group 3, 3: memory group 4, 4: memory group 5, 5: memory group 6, 6: memory group 7)

--Example.

Set the remote control of RUN in STEP 1 to: Memory Group 1

Setting command: FUNC:SOUR:STEP 1: RUN:PLC 0

Query command: FUNC:SOUR:STEP 1: RUN:PLC?

Return value: 0



voltage

FUNC:SOURce:STEP:RUN:ACSOUR:VOLT Set/query RUN AC source

(TH9130 only)

--Format:

Setting format:

FUNC:SOUR:STEP <sn>:RUN:ACSOUR:VOLT <Voltage Value>

Query format: FUNC:SOUR:STEP <sn>:RUN:ACSOUR:VOLT?

--Data <voltage value>:

Data type: floating point number

Data range: 0.0~277.0

Data accuracy: 0.1

Data unit: V

--Example:

Set the RUN AC source voltage in STEP 1 to 250V.

Setting command: FUNC:SOUR:STEP 1:RUN:ACSOUR:VOLT

250

Query command: FUNC:SOUR:STEP 1:RUN:ACSOUR:VOLT?

Return value: 250



frequency.

FUNC:SOURce:STEP:RUN:ACSOUR:FREQ Set/query the RUN AC source

(TH9130 only)

--Format:

Setting format:

FUNC:SOUR:STEP <sn>:RUN:ACSOUR:FREQ <frequency>

Query format: FUNC:SOUR:STEP <sn>:RUN:ACSOOR:FREQ?
 --Data<frequency>:
 Data type: floating point number
 Data range: 45.0~500.0
 Data accuracy: 0.1
 Data unit: Hz
 --Example:
 Set the RUN AC source frequency in STEP 1 to: 400Hz
 Setting command: FUNC:SOUR:STEP 1:RUN:ACSOOR:FREQ

400

Query command: FUNC:SOUR:STEP 1:RUN:ACSOOR:FREQ?
 Return value: 400

◆ **FUNC:SOURce:STEP:RUN:ACSOOR:UPPC** Set/query the upper limit of RUN AC source current

(TH9130 only)

--Format:
 Setting format:
 FUNC:SOUR:STEP <sn>:RUN:ACSOOR:UPPC <current value>.
 Query format: FUNC:SOUR:STEP <sn>:RUN:ACSOOR:UPPC?
 --Data <current value>:
 Data type: floating point number
 Data range: 0.0 to 4.2 (low), 0.0 to 2.1 (high) (0 means off)
 Data accuracy: 0.1
 Data unit: A
 --Example:
 Set the upper limit of RUN AC source current in STEP 1 to: 2A
 Setting command: FUNC:SOUR:STEP 1:RUN:ACSOOR:UPPC 2
 Query command: FUNC:SOUR:STEP 1:RUN:ACSOOR:UPPC?
 Return value: 2

◆ **FUNC:SOURce:STEP:RUN:ACSOOR:NG** Set/query the RUN AC source zero ground setting

(TH9130 only)

--Format:
 Setting format: FUNC:SOUR:STEP <sn>:RUN:ACSOOR:NG

<state>

Query format: FUNC:SOUR:STEP <sn>:RUN:ACSOOR:NG?
 --Data<status>:
 Data type: character
 Data range: OFF (0), ON (1)
 --Example:
 Set the RUN AC source zero ground in STEP 1 to: ON
 Setting command: FUNC:SOUR:STEP 1: RUN: ACSOOR:NG 1
 Query command: FUNC:SOUR:STEP 1: RUN: ACSOOR:NG?
 Return value: 1

◆ **FUNC:SOURce:STEP:RUN:ACSOOR:RANG** Set/query the RUN AC source

voltage range.

(TH9130 only)

--Format:

Setting format:

FUNC:SOUR:STEP <sn>:RUN:ACSOOR:RANG <state>

Query format: FUNC:SOUR:STEP <sn>:RUN:ACSOOR:RANG?

--Data<status>:

Data type: character

Data range: 0 to 1 (0: LOW, 1: HIGH)

--Example:

Set the RUN AC source voltage range in STEP 1 to: High Grade

Setting command: FUNC:SOUR:STEP 1: RUN: ACSOOR:RANG 1

Query command: FUNC:SOUR:STEP 1: RUN: ACSOOR:RANG?

Return value: 1

- ◆ **FUNC:SOURce:STEP:RUN:ACSOOR:FOLD** (available only with TH9130)
Set/query RUN AC source overload constant current setting

--Format:

Setting format:

FUNC:SOUR:STEP <sn>:RUN:ACSOOR:FOLD <state>

Query format: FUNC:SOUR:STEP <sn>:RUN:ACSOOR:FOLD?

--Data<status>:

Data type: character

Data range: OFF (0), ON (1)

--Example:

Set the RUN AC source overload constant current in STEP 1 to:

ON

Setting command: FUNC:SOUR:STEP 1: RUN: ACSOOR:FOLD 1

Query command: FUNC:SOUR:STEP 1: RUN: ACSOOR:FOLD?

Return value: 1

4.2.3.10 LC Setup Function Command Set (only available for

TH9130/TH9131)

- ◆ **FUNC:SOURce:STEP:LC:UPPL** Set/query the upper limit of LC leakage current.

current value

--Format:

Setting format: FUNC:SOUR:STEP <sn>:LC:UPPL <leakage

Query format: FUNC:SOUR:STEP <sn>:LC:UPPL?

--Data <leakage current value>:

Data type: floating point number

Data range: 0.0~10000, 0 means off

Data accuracy: 0.1

Data unit: uA

--Example:

Set the upper limit of leakage current of LC in STEP 1 to 3000uA.

Setting commands: FUNC:SOUR:STEP 1:LC:UPPL 3000

Query command: FUNC:SOUR:STEP 1:LC:UPPL?

Return value: 3000

- ◆ **FUNC:SOURce:STEP: LC:LOWL** Set/query the lower limit of LC leakage current.

--Format:

Setting format: FUNC:SOUR:STEP <sn>:LC:LOWL <leakage

Query format: FUNC:SOUR:STEP <sn>:LC:LOWL?

current value

--Data <leakage current value>:

Data type: floating point number

Data range: 0.0 to upper limit

Data accuracy: 0.1

Data unit: uA

--Example:

Set the lower limit of leakage current of LC in STEP 1 to 100.0uA

Setting command: FUNC:SOUR:STEP 1:LC:LOWL 100

Query command: FUNC:SOUR:STEP 1:LC:LOWL?

Return value: 100

- ◆ **FUNC:SOURce:STEP:LC:UPPV** Set/query the upper limit of LC voltage.

--Format:

Setting format: FUNC:SOUR:STEP <sn>:LC:UPPV <voltage value

Query format: FUNC:SOUR:STEP <sn>:LC:UPPV?

--Data <voltage value>:

Data type: floating point number

Data range: 0.0~277.0

Data accuracy: 0.1

Data unit: V

--Example:

Set the upper voltage limit of LC in STEP 1 to: 250V

Setting command: FUNC:SOUR:STEP 1:LC:UPPV 250

Query command: FUNC:SOUR:STEP 1:LC:UPPV?

Return value: 250

- ◆ **FUNC:SOURce:STEP: LC:LOWV** Set/query the lower limit of LC voltage.

--Format:

Setting format: FUNC:SOUR:STEP <sn>:LC:LOWV <voltage

value

Query format: FUNC:SOUR:STEP <sn>:LC:LOWV?

--Data <voltage value>:

Data type: floating point number

Data range: 0.0 to upper limit

Data accuracy: 0.1

Data unit: V

--Example:

Set the voltage lower limit of LC in STEP 1 to: 10V

Setting command: FUNC:SOUR:STEP 1:LC:LOWV 10

Query command: FUNC:SOUR:STEP 1:LC:LOWV?

Return value: 10

◆ **FUNC:SOURce:STEP:LC:TTIM** Set/query the test time of LC.

--Format:

Setting format: FUNC:SOUR:STEP <sn>:LC:TTIM <Time value>

Query format: FUNC:SOUR:STEP <sn>:LC:TTIM?

--Data<time value>:

Data type: floating point number

Data range: 0, 0.1 to 999.9s (0 indicates continuous)

Data accuracy: 0.1s

Data unit: s

--Example:

Set the test time for LC in STEP 1 to: 1s

Setting command: FUNC:SOUR:STEP 1:LC:TTIM 1

Query command: FUNC:SOUR:STEP 1:LC:TTIM?

Return value: 1.0

◆ **FUNC:SOURce:STEP:LC:WTIM** Set/query the LC wait time.

--Format:

Setting Format: FUNC:SOUR:STEP <sn>:LC:WTIM <time value>

Query format: FUNC:SOUR:STEP <sn>:LC:WTIM?

--Data<time value>:

Data type: floating point number

Data range: 0.5 to 999.9s

Data accuracy: 0.1s

Data unit: s

--Example:

Set the wait time for LC in STEP 1 to: 1s

Setting command: FUNC:SOUR:STEP 1:LC:WTIM 1

Query command: FUNC:SOUR:STEP 1:LC:WTIM?

Return value: 1.0

Return value: 1

◆ **FUNC:SOURce:STEP:LC:NEUT** Set/query the LC zero switch setting status.

--Format:

Setting format: FUNC:SOUR:STEP <sn>:LC:NEUT <state>

Query format: FUNC:SOUR:STEP <sn>:LC:NEUT?

--Data<status>:

Data type: character

Data range: 0 to 1 (0: closed, 1: open)

--Example:

Set the zero-line switch of LC in STEP 1 to: closed

Setting command: FUNC:SOUR:STEP 1:LC:NEUT 0

Query command: FUNC:SOUR:STEP 1:LC:NEUT?

Return value: 0

- ◆ **FUNC:SOURce:STEP:LC:REVE** Set/query the polarity reversal status of LC.

--Format:

Setting format: FUNC:SOUR:STEP <sn>:LC:REVE <state>

Query format: FUNC:SOUR:STEP <sn>:LC:REVE?

--Data<status>:

Data type: character

Data range: 0 to 2 (0: off, 1: on, 2: Automatic)

--Example:

Set the LC polarity reversal switch in STEP 1 to: OFF

Setting command: FUNC:SOUR:STEP 1:LC:REVE 0

Query command: FUNC:SOUR:STEP 1:LC:REVE?

Return value: 0

- ◆ **FUNC:SOURce:STEP:LC: TGND** Set/query the status of the LC ground switch setting.

--Format:

Setting format: FUNC:SOUR:STEP <sn>:LC:TGND <state>

Query format: FUNC:SOUR:STEP <sn>:LC:TGND?

--Data<status>:

Data type: character

Data range: 0 to 1 (0: closed, 1: open)

--Example:

Set the ground switch of LC in STEP 1 to: closed

Setting command: FUNC:SOUR:STEP 1:LC:TGND 0

Query command: FUNC:SOUR:STEP 1:LC:TGND?

Return value: 0

- ◆ **FUNC:SOURce:STEP:LC:MD** Set/query the MD human body network status of the LC.

--Format:

Setting format: FUNC:SOUR:STEP <sn>:LC:MD <state>

Query format: FUNC:SOUR:STEP <sn>:LC:MD?

--Data<status>:

Data type: character

Data range: 0~9 (0: UL544NP, 1: UL544P, 2: UL2601, 3: UL1563, 4: IEC60990 Fig4-U1, 5: IEC60990 Fig4-U2,

6: IEC60990 Fig5-U1, 7: IEC60990 Fig5-U3, 8:

External, 9: Frequency Check,10: GB4793.1) (see technical specifications for details of specific standards)

--Example:

Set the body impedance of the LC in STEP 1 to UL544NP:

Setting command: FUNC:SOUR:STEP 1:LC:MD 0

Query command: FUNC:SOUR:STEP 1:LC:MD?

Return value: 0

- ◆ **FUNC:SOURce:STEP:LC:PROBE** Set/query the probe status of the LC.
- Format:
 Setting format: FUNC:SOUR:STEP <sn>:LC:PROBE <state>
 Query format: FUNC:SOUR:STEP <sn>:LC:PROBE?
- Data<status>:
 Data type: character
 Data range: 0 to 4 (0: ground to fire, 1: probe to fire, 2: probe to probe, 3: ground to zero, 4: Automatic)
- Example:
 Set the LC probe in STEP 1 to: ground to firewire
 Setting command: FUNC:SOUR:STEP 1:LC:PROBE 0
 Query command: FUNC:SOUR:STEP 1:LC:PROBE?
 Return value: 0
- ◆ **FUNC:SOURce:STEP:LC: RMSPEAK** Set/query LC RMS/peak status.
- Format:
 Setting format: FUNC:SOUR:STEP <sn>:LC:RMSPEAK <state>
 Query format: FUNC:SOUR:STEP <sn>:LC:RMSPEAK?
- Data<status>:
 Data type: character
 Data range: 0~1 (0: RMS, 1: PEAK peak)
- Example:
 Set the RMS/peak value of the LC in STEP 1 to: RMS
 Setting command: FUNC:SOUR:STEP 1:LC:RMSPEAK 0
 Query command: FUNC:SOUR:STEP 1:LC:RMSPEAK?
 Return value: 0
- ◆ **FUNC:SOURce:STEP:LC: ACDC** Set/query the AC-DC status of the LC.
- Format:
 Setting format: FUNC:SOUR:STEP <sn>:LC:ACDC <state>
 Query format: FUNC:SOUR:STEP <sn>:LC:ACDC?
- Data<status>:
 Data type: character
 Data range: 0~2 (0: AC, 1: DC, 2: AC+DC)
- Example:
 Set the AC DC of the LC in STEP 1 to: AC
 Setting command: FUNC:SOUR:STEP 1:LC:ACDC 0
 Query command: FUNC:SOUR:STEP 1:LC:ACDC?
 Return value: 0
- ◆ **FUNC:SOURce:STEP:LC: RANG** Set/query the LC auto-range status.
- Format:
 Setting format: FUNC:SOUR:STEP <sn>:LC:RANG <state>
 Query format: FUNC:SOUR:STEP <sn>:LC:RANG?
- Data<status>:
 Data type: character

Data range: 0 to 1 (0: off, 1: on)

--Example:

Set the auto range of LC in STEP 1 to: OFF

Setting command: FUNC:SOUR:STEP 1:LC:RANG 0

Query command: FUNC:SOUR:STEP 1:LC:RANG?

Return value: 0

◆ **FUNC:SOURce:STEP:LC:PLC** Set/query LC remote control settings.

--Format:

Setting format: FUNC:SOUR:STEP <sn>:LC:PLC <state>

Query format: FUNC:SOUR:STEP <sn>:LC:PLC?

--Data<status>:

Data type: character

Data range: 0 to 6 (0: memory group 1, 1: memory group 2, 2: memory group 3, 3: memory group 4, 4: memory group 5, 5: memory group 6, 6: memory group 7)

--Example:

Set the remote control of LC in STEP 1 to: Memory Group 1

Setting command: FUNC:SOUR:STEP 1:LC:PLC 0

Query command: FUNC:SOUR:STEP 1:LC:PLC?

Return value: 0

◆ **FUNC:SOURce:STEP:LC:ACSOUR:VOLT** Set/query the LC AC source voltage.

(TH9130 only)

--Format:

Setting format:

FUNC:SOUR:STEP <sn>:LC:ACSOUR:VOLT <voltage value>

Query format: FUNC:SOUR:STEP <sn>:LC:ACSOUR:VOLT?

--Data <voltage value>:

Data type: floating point number

Data range: 0.0~277.0

Data accuracy: 0.1

Data unit: V

--Example:

Set the LC AC source voltage in STEP 1 to: 250V

Setting command: FUNC:SOUR:STEP 1:LC:ACSOUR:VOLT 250

Query command: FUNC:SOUR:STEP 1:LC:ACSOUR:VOLT?

Return value: 250

◆ **FUNC:SOURce:STEP: LC:ACSOUR:FREQ** Set/query the LC AC source frequency.

(TH9130 only)

--Format:

Setting format:

FUNC:SOUR:STEP <sn>:LC:ACSOUR:FREQ <frequency>.

Query format: FUNC:SOUR:STEP <sn>:LC:ACSOUR:FREQ?

--Data<frequency>:
 Data type: floating point number
 Data range: 45.0~500.0
 Data accuracy: 0.1
 Data unit: Hz
 --Example:
 Set the LC AC source frequency in STEP 1 to: 400Hz
 Setting command: FUNC:SOUR:STEP 1:LC:ACSOUR:FREQ 400
 Query command: FUNC:SOUR:STEP 1:LC:ACSOUR:FREQ?
 Return value: 400

- ◆ **FUNC:SOURce:STEP: LC:ACSOUR:UPPC** Set/query the upper limit of LC AC source current.

(TH9130 only)

--Format:
 Setting format:
 FUNC:SOUR:STEP <sn>:LC:ACSOUR:UPPC <current value>.
 Query format: FUNC:SOUR:STEP <sn>:LC:ACSOUR:UPPC?
 --Data <current value>:
 Data type: floating point number
 Data range: 0.0 to 4.2 (low), 0.0 to 2.1 (high) (0 means off)
 Data accuracy: 0.1
 Data unit: A
 --Example:
 Set the upper limit of LC AC source current in STEP 1 to: 2A
 Setting command: FUNC:SOUR:STEP 1:LC:ACSOUR:UPPC 2
 Query command: FUNC:SOUR:STEP 1:LC:ACSOUR:UPPC?
 Return value: 2

- ◆ **FUNC:SOURce:STEP: LC:ACSOUR:NG** Set/query the LC AC source zero ground setting.

(TH9130 only)

--Format:
 Setting format: FUNC:SOUR:STEP <sn>:LC:ACSOUR:NG
 <state>
 Query format: FUNC:SOUR:STEP <sn>:LC:ACSOUR:NG?
 --Data<status>:
 Data type: character
 Data range: OFF (0), ON (1)
 --Example:
 Set the LC AC source zero ground in STEP 1 to: ON
 Setting command: FUNC:SOUR:STEP 1:LC: ACSOUR:NG 1
 Query command: FUNC:SOUR:STEP 1:LC: ACSOUR:NG?
 Return value: 1

- ◆ **FUNC:SOURce:STEP: LC:ACSOUR:RANG** Set/query the LC AC source voltage range.

(TH9130 only)

--Format:

Setting format:

FUNC:SOUR:STEP <sn>:LC:ACSOUR:RANG <state>

Query format: FUNC:SOUR:STEP <sn>:LC:ACSOUR:RANG?

--Data<status>:

Data type: character

Data range: 0 to 1 (0: LOW, 1: HIGH)

--Example:

Set the LC AC source voltage range in STEP 1 to: High Grade

Setting command: FUNC:SOUR:STEP 1:LC:ACSOUR:RANG 1

Query command: FUNC:SOUR:STEP 1:LC:ACSOUR:RANG?

Return value: 1

- ◆ **FUNC:SOURce:STEP: LC:ACSOUR:FOLD** Set/query the LC AC source overload constant current setting.

(TH9130 only)

--Format:

Setting format:

FUNC:SOUR:STEP <sn>:LC:ACSOUR:FOLD <status>.

Query format: FUNC:SOUR:STEP <sn>:LC:ACSOUR:FOLD?

--Data<status>:

Data type: character

Data range: OFF (0), ON (1)

--Example:

Set the LC AC source overload constant current setting in STEP 1

to: ON

Setting command: FUNC:SOUR:STEP 1:LC:ACSOUR:FOLD 1

Query command: FUNC:SOUR:STEP 1:LC:ACSOUR:FOLD?

Return value: 1

4.2.3.11 BREAKDOWN VOLT Function Command Set

- ◆ **FUNC:BREAKdown:AC:VOLTSstart** Set/query the starting voltage for the AC breakdown test.

--Format:

Setting format: FUNC:BREAK:AC:VOLTS <VOLTAGE value

Query Format: FUNC:BREAK:AC:VOLTS?

--Data <voltage value>:

Data type: floating point number

Data range: 0.050~termination voltage

Data accuracy: 0.001

Data unit: kV

--Example:

Set the starting voltage for the AC voltage breakdown test to 1kV.

Setting command: FUNC:BREAK:AC:VOLTS 1.000

Query command: FUNC:BREAK:AC:VOLTS?

Return value: 1.000

- ◆ **FUNC:BREAKdown:AC:VOLTEnd** Set/query the termination voltage of the AC breakdown test.

--Format:

Setting format: FUNC:BREAK:AC:VOLTE <VOLTAGE>

Query Format: FUNC:BREAK:AC:VOLTE?

--Data <voltage value>:

Data type: floating point number

Data range: 0.050~5.000

Data accuracy: 0.001

Data unit: kV

--Example:

Set the termination voltage of the AC voltage breakdown test to 5kV.

Setting command: FUNC:BREAK:AC:VOLTE 5.000

Query command: FUNC:BREAK:AC:VOLTE?

Return value: 5.000

- ◆ **FUNC:BREAKdown:AC:STEPVOLT** Set/query the step voltage for AC breakdown test.

--Format:

Setting format: FUNC:BREAK:AC:STEPVOLT <stepping voltage>

Query Format: FUNC:BREAK:AC:STEPVOLT?

--Data <stepping voltage>:

Data type: floating point number

Data range: 0.005~0.500

Data accuracy: 0.001

Data unit: kV

--Example:

Set the step voltage of AC voltage breakdown test to 50V.

Setting command: FUNC:BREAK:AC:STEPVOLT 0.050

Query command: FUNC:BREAK:AC:STEPVOLT?

Return value: 0.050

- ◆ **FUNC:BREAKdown:AC:STEP** Set/query the number of test steps for the AC breakdown test.

--Format:

Setting format: FUNC:BREAK:AC:STEP <number of steps>

Query Format: FUNC:BREAK:AC:STEP?

--Data <number of steps>:

Data type: integer

Data range: 2~999

Data accuracy: 1

--Example:

Set the number of test steps for the AC voltage breakdown test to 55.

Setting command: FUNC:BREAK:AC:STEP 55

Query command: FUNC:BREAK:AC:STEP?

Return value: 55

- ◆ **FUNC:BREAKdown:AC:UPPC** Set/query the upper limit current of AC voltage breakdown test

--Format:

Setting format: FUNC:BREAK:AC:UPPC <current value>

Query Format: FUNC:BREAK:AC:UPPC?

--Data <current value>:

Data type: floating point number

Data range: 0.001 to 100mA

Data accuracy: 0.001mA

Data unit: mA

--Example:

Set the upper limit of current for AC voltage breakdown test to 10mA.

Setting command: FUNC:BREAK:AC:UPPC 10

Query command: FUNC:BREAK:AC:UPPC?

Return value: 10.000

- ◆ **FUNC:BREAKdown:AC:LOWC** Set/query the lower limit current for AC voltage breakdown test.

--Format:

Setting format: FUNC:BREAK:AC:LOWC <Current value>

Query Format: FUNC:BREAK:AC:LOWC?

--Data <current value>:

Data type: floating point number

Data range: 0 to upper limit current value (0 means off)

Data accuracy: 0.001mA

Data unit: mA

--Example:

Set the lower current limit of AC voltage breakdown test to 1mA.

Setting command: FUNC:BREAK:AC:LOWC 1

Query command: FUNC:BREAK:AC:LOWC?

Return value: 1.000

- ◆ **FUNC:BREAKdown:AC:TTIM** Set/query the test time of AC voltage breakdown test.

--Format:

Setting format: FUNC:BREAK:AC:TTIM <Time value>

Query Format: FUNC:BREAK:AC:TTIM?

--Data<time value>:

Data type: floating point number

Data range: 0, 0.3 to 999.0s (0 means off)

Data accuracy: 0.1s

Data unit: s

--Example:

Set the test time for AC voltage breakdown test to 1s
 Setting command: FUNC:BREAK:AC:TTIM 1
 Query command: FUNC:BREAK:AC:TTIM?
 Return value: 1.0

- ◆ **FUNC:BREAKdown:AC:RTIM** Set/query the rise time for AC voltage breakdown test.

--Format:
 Setting format: FUNC:BREAK: AC:RTIM<time value>
 Query Format: FUNC:BREAK:AC:RTIM?

--Data<time value>:
 Data type: floating point number
 Data range: 0 to 999.0s (0 means off)
 Data accuracy: 0.1s
 Data unit: s

--Example:
 Set the rise time of the AC voltage breakdown test to: 1s
 Setting command: FUNC:BREAK:AC:RTIM 1
 Query command: FUNC:BREAK:AC:RTIM?
 Return value: 1.0

- ◆ **FUNC:BREAK:AC:ARC** Set/query the upper limit of ARC current for AC voltage breakdown test.

--Format:
 Setting format: FUNC:BREAK:AC:ARC <Current value>
 Query Format: FUNC:BREAK:AC:ARC?

--Data <current value>:
 Data type: floating point number
 Data range: 0, 1.0 ~ 20mA (0 for off)
 Data accuracy: 0.1mA
 Data unit: mA

--Example:
 Set the upper limit of ARC current for AC voltage breakdown test to

5mA.

Setting command: FUNC:BREAK:AC:ARC 5
 Query command: FUNC:BREAK:AC:ARC?
 Return value: 5.0

- ◆ **FUNC:BREAKdown:AC:CONTinue** Set/query the AC voltage breakdown continuity test switch.

--Format:
 Setting format: FUNC:BREAK:AC:CON <Switch>
 Query Format: FUNC:BREAK:AC:CONT?

--Data<switch>:
 Data type: integer
 Data range: 0, 1 (0: OFF; 1: ON)

--Example:

Set the AC voltage breakdown continuity test switch to: 1 (ON)
 Setting command: FUNC:BREAK:AC:CONT 1
 Query command: FUNC:BREAK:AC:CONT?
 Return value: 1

- ◆ **FUNC:BREAKdown:DC:VOLTSstart** Set/query the starting voltage of the DC breakdown test.

--Format:

Setting format: FUNC:BREAK:DC:VOLTS <voltage value>

Query Format: FUNC:BREAK:DC:VOLTS?

--Data <voltage value>:

Data type: floating point number

Data range: 0.050~termination voltage

Data accuracy: 0.001

Data unit: kV

--Example:

Set the starting voltage for the DC voltage breakdown test to 1kV.

Setting command: FUNC:BREAK:DC:VOLTS 1.000

Query command: FUNC:BREAK:DC:VOLTS?

Return value: 1.000

- ◆ **FUNC:BREAKdown:DC:VOLTEnd** Set/query the termination voltage of the DC breakdown test.

--Format:

Setting format: FUNC:BREAK:DC:VOLTE <VOLTAGE value>

Query Format: FUNC:BREAK:DC:VOLTE?

--Data <voltage value>:

Data type: floating point number

Data range: 0.050~6.000

Data accuracy: 0.001

Data unit: kV

--Example:

Set the termination voltage of the DC voltage breakdown test to

5kV.

Setting command: FUNC:BREAK:DC:VOLTE 5.000

Query command: FUNC:BREAK:DC:VOLTE?

Return value: 5.000

- ◆ **FUNC:BREAKdown:DC:STEPVOLT** Set/query the step voltage for DC breakdown test.

--Format:

Setting format: FUNC:BREAK:DC:STEPVOLT <stepping voltage>

Query Format: FUNC:BREAK:DC:STEPVOLT?

--Data <stepping voltage>:

Data type: floating point number

Data range: 0.005~0.500

Data accuracy: 0.001

Data unit: kV

--Example:

Set the step voltage for the DC voltage breakdown test to: 50V

Setting command: FUNC:BREAK:DC:STEPVOLT 0.050

Query command: FUNC:BREAK:DC:STEPVOLT?

Return value: 0.050

- ◆ **FUNC:BREAKdown:DC:STEP** Set/query the number of test steps for the DC breakdown test.

--Format:

Setting format: FUNC:BREAK:DC:STEP <number of steps>

Query Format: FUNC:BREAK:DC:STEP?

--Data <number of steps>:

Data type: integer

Data range: 2~999

Data accuracy: 1

--Example:

Set the number of test steps for the DC voltage breakdown test to

55.

Setting command: FUNC:BREAK:DC:STEP 55

Query command: FUNC:BREAK:DC:STEP?

Return value: 55

- ◆ **FUNC:BREAKdown:DC:UPPC** Set/query the upper limit current for DC voltage breakdown test.

--Format:

Setting format: FUNC:BREAK:DC:UPPC <Current Value

Query Format: FUNC:BREAK:DC:UPPC?

--Data <current value>:

Data type: floating point number

Data range: 0.0001~25mA

Data accuracy: 0.0001mA

Data unit: mA

--Example:

Set the upper current limit of DC voltage breakdown test to 10mA.

Setting command: FUNC:BREAK:DC:UPPC 10

Query command: FUNC:BREAK:DC:UPPC?

Return value: 10.0000

- ◆ **FUNC:BREAKdown:DC:LOWC** Set/query the lower limit current for DC voltage breakdown test.

--Format:

Setting format: FUNC:BREAK:DC:LOWC <current value

Query Format: FUNC:BREAK:DC:LOWC?

--Data <current value>:

Data type: floating point number

Data range: 0 to upper limit current value (0 means off)

Data accuracy: 0.0001mA

Data unit: mA

--Example:

Set the lower current limit of the DC voltage breakdown test to:

1mA

Setting command: FUNC:BREAK:DC:LOWC 1

Query command: FUNC:BREAK:DC:LOWC?

Return value: 1.0000

- ◆ **FUNC:BREAKdown:DC:TTIM** Set/query the test time of DC voltage breakdown test

--Format:

Setting format: FUNC:BREAK:DC:TTIM <Time value>

Query Format: FUNC:BREAK:DC:TTIM?

--Data<time value>:

Data type: floating point number

Data range: 0, 0.3 to 999.0s (0 means off)

Data accuracy: 0.1s

Data unit: s

--Example:

Set the test time for the DC voltage breakdown test to: 1s

Setting command: FUNC:BREAK:DC:TTIM 1

Query command: FUNC:BREAK:DC:TTIM?

Return value: 1.0

- ◆ **FUNC:BREAKdown:DC:RTIM** Set/query the rise time for DC voltage breakdown test.

--Format:

Setting format: FUNC:BREAK:DC:RTIM <Time value>

Query Format: FUNC:BREAK:DC:RTIM?

--Data<time value>:

Data type: floating point number

Data range: 0 to 999.0s (0 means off)

Data accuracy: 0.1s

Data unit: s

--Example:

Set the DC voltage breakdown test rise time to: 1s

Setting command: FUNC:BREAK:DC:RTIM 1

Query command: FUNC:BREAK:DC:RTIM?

Return value: 1.0

- ◆ **FUNC:BREAKdown:DC:WTIM** Set/query the wait time for the DC voltage breakdown test.

--Format:

Setting format: FUNC:BREAK:DC:WTIM <Time value>

Query Format: FUNC:BREAK:DC:WTIM?

--Data<time value>:

Data type: floating point number

Data range: 0 to 999.0s (0 means off)

Data accuracy: 0.1s

Data unit: s

--Example:

Set the wait time for DC voltage breakdown test to: 1s

Setting command: FUNC:BREAK:DC:WTIM 1

Query command: FUNC:BREAK:DC:WTIM?

Return value: 1.0

- ◆ **FUNC:BREAK:DC:ARC** Set/query the upper limit of ARC current for DC voltage breakdown test.

--Format:

Setting format: FUNC:BREAK:DC:ARC <current value>

Query Format: FUNC:BREAK:DC:ARC?

--Data <current value>:

Data type: floating point number

Data range: 0, 1.0 to 10.0mA (0 means off)

Data accuracy: 0.1mA

Data unit: mA

--Example:

Set the upper limit of ARC current for DC voltage breakdown test to 5mA.

Setting command: FUNC:BREAK:DC:ARC 5

Query command: FUNC:BREAK:DC:ARC?

Return value: 5.0

- ◆ **FUNC:BREAKdown:DC:CONTinue** Set/query the DC voltage breakdown continuity test switch.

--Format:

Setting format: FUNC:BREAK:DC:CONT <Switch>

Query Format: FUNC:BREAK:DC:CONT?

--Data<switch>:

Data type: integer

Data range: 0, 1 (0: OFF; 1: ON)

--Example:

Set the DC voltage breakdown continuity test switch to: 1 (ON)

Setting command: FUNC:BREAK:DC:CONT 1

Query command: FUNC:BREAK:DC:CONT?

Return value: 1

- ◆ **FUNC:BREAKdown:SAVE** Save the contents of the voltage breakdown test settings.

--Example:

Save the contents of voltage breakdown test settings

Setting command: FUNC:BREAK:SAVE

4.2.4 SYSTem Subsystem Commands Set

4.2.4.1 MEA Setup Function Command Set

- ◆ **SYSTem:MEA:TRGMODE** Set/query the triggering method of the test.
 - Format:
 - Setting format: SYSTem:MEA:TRGMODE <way>
 - Query format: SYSTem:MEA:TRGMODE ?
 - Data<mode>:
 - Data type: character
 - Data range: 0 to 2 (0: manual, 1: external, 2: bus)
 - Example:
 - Set the trigger method to: Manual
 - Setting command: SYSTem:MEA:TRGMODE 0
 - Query command: SYSTem:MEA:TRGMODE ?
 - Return value: 0

- ◆ **SYSTem:MEA:TRGDLY** Set/query the trigger delay for the test.
 - Format:
 - Setting format: SYSTem:MEA: TRGDLY <time value>
 - Query format: SYSTem:MEA:TRGDLY?
 - Data<time value>:
 - Data type: floating point number
 - Data range: 0.0 to 99.9s
 - Data accuracy: 0.1s
 - Data unit: s
 - Example:
 - Set the trigger delay to: 1.0s
 - Setting command: SYSTem:MEA:TRGDLY 1.0
 - Query command: SYSTem:MEA:TRGDLY?
 - Return value: 1.0

- ◆ **SYSTem:MEA:MEAMODE** Set/query the mode of the testing.
 - Format:
 - Setting format: SYSTem:MEA: MEAMODE <way>
 - Query format: SYSTem:MEA:MEAMODE ?
 - Data<mode>:
 - Data type: character
 - Data range: 0 to 4 (0: Normal, 1: Repeat, 2: Cycle, 3: Single step, 4: Breakdown)
 - Example:
 - Set the test mode to: Normal
 - Setting command: SYSTem:MEA:MEAMODE 0
 - Query command: SYSTem:MEA:MEAMODE?
 - Return value: 0

- ◆ **SYSTem:MEA:RPTCNT** Set/query the number of repetitions of the test.

--Format:
 Setting format: SYSTem:MEA:RPTCNT <number of times>
 Query format: SYSTem:MEA:RPTCNT?
 --Data <number of times>:
 Data type: integer
 Data range: 0 to 999
 Data accuracy: 1
 --Example:
 Set the number of repetitions to: 2
 Setting command: SYSTem:MEA:RPTCNT 2
 Query command: SYSTem:MEA:RPTCNT?
 Return value: 2

◆ **SYSTem:MEA:RPTINT** Set/query test interval for testing.

--Format:
 Setting format: SYSTem:MEA:RPTINT <Time value>
 Query format: SYSTem:MEA:RPTINT?
 --Data<time value>:
 Data type: floating point number
 Data range: 0.0 to 99.9s
 Data accuracy: 0.1s
 Data unit: s
 --Example:
 Set the test interval to: 1.0s
 Setting command: SYSTem:MEA:RPTINT 1.0
 Query command: SYSTem:MEA:RPTINT?
 Return value: 1.0

◆ **SYSTem:MEA:AFTERFAIL** Set/query the status after a test failure.

--Format:
 Setting format: SYSTem:MEA:AFTERFAIL <state>
 Query format: SYSTem:MEA:AFTERFAIL ?
 --Data<mode>:
 Data type: character
 Data range: 0 to 2 (0: continue, 1: resume, 2: stop)
 --Example:
 Set the status of the test after failure to: continue
 Setting command: SYSTem:MEA:AFTERFAIL 0
 Query command: SYSTem:MEA:AFTERFAIL?
 Return value: 0

◆ **SYSTem:MEA:PASSHOLD** Set/query the beep response time for passing the test.

--Format:
 Setting format: SYSTem:MEA:PASSHOLD <Time value>
 Query format: SYSTem:MEA: PASSHOLD ?
 --Data<time value>:
 Data type: floating point number

Data range: 0.2 to 99.9s

Data accuracy: 0.1s

Data unit: s

--Example:

Set the response time of the tested buzzer to: 1.0s

Setting command: SYSTem:MEA:PASSHOLD 1.0

Query command: SYSTem:MEA:PASSHOLD?

Return value: 1.0

◆ **SYSTem:MEA:STEPHOLD** Set/query the inter-item hold time for test STEPs.

--Format:

Setting format: SYSTem:MEA:STEPHOLD <Time value>

Query format: SYSTem:MEA:STEPHOLD ?

--Data<time value>:

Data type: floating point number

Data range: 0.1 to 99.9s, KEY

Data accuracy: 0.1s

Data unit: s

--Example:

Set the inter-item hold time of the test STEP to: 1.0s

Setting command: SYSTem:MEA:STEPHOLD 1.0

Query command: SYSTem:MEA:STEPHOLD?

Return value: 1.0

◆ **SYSTem:MEA:GFI** Set/query the status of electric shock protection.

--Format:

Set the format:

SYSTem:MEA:GFI <ON/OFF>or<1/0>

Query format: SYSTem:MEA:GFI?

--Data <ON/OFF>:

Data type: character

Data range: OFF (0), ON (1)

--Example:

Set the electric shock protection to: 1

Setting command: SYSTem:MEA:GFI 1

Query command: SYSTem:MEA:GFI?

Return value: 1

◆ **SYSTem:MEA:ACSOURCE** Set/query the status of the AC power supply.

(TH9130 only)

--Format:

Setting format:

SYSTem:MEA:ACSOURCEI <ON/OFF>or<1/0>

Query format: SYSTem:MEA:ACSOURCE?

--Data <ON/OFF >:

Data type: character

Data range: OFF (0), ON (1)

--Example:

Set the AC power supply to: 1
 Setting command: SYSTem:MEA:ACSOURCE 1
 Query command: SYSTem:MEA:ACSOURCE?
 Return value: 1

- ◆ **SYSTem:MEA:DUTOUT** Set/query the status of the backplane output.

(available only for TH9130/TH9131)

--Format:
 Setting format:
 SYSTem:MEA:DUTPOUT <ON/OFF >or<1/0>
 Query format: SYSTem:MEA:DUTOUT?
 --Data <ON/OFF>:
 Data type: character
 Data range: OFF (0), ON (1)
 --Example:
 Set the backplane output to: 1
 Setting command: SYSTem:MEA:DUTOUT 1
 Query command: SYSTem:MEA:DUTOUT?
 Return value: 1

4.2.4.2 ENV Setup Function Command Set

- ◆ **SYSTem:ENV:KEYVOL** Set/query the status of the key sound.

--Format:
 Setting format: SYSTem:ENV:KEYVOL <ON/OFF>or<1/0>
 Query format: SYSTem:ENV:KEYVOL?
 --Data <ON/OFF>:
 Data type: character
 Data range: OFF (0), ON (1)
 --Example:
 Set the key sound status to: ON
 Setting command: SYSTem:ENV:KEYVOL 1
 Query command: SYSTem:ENV:KEYVOL?
 Return value: 1

- ◆ **SYSTem:ENV:BEEPVOL** Set/query the status of the buzzer sound.

--Format:
 Setting format: SYSTem:ENV:BEEPVOL <Volume value>
 Query format: SYSTem:ENV:BEEPVOL?
 --Data<volume value>:
 Data type: character
 Data range: 0 to 3 (0:OFF1:LOW, 2:MED, 3:HIGH)
 --Example:
 Set the buzzer sound status to: HIGH
 Setting command: SYSTem:ENV:BEEPVOL 3
 Query command: SYSTem:ENV:BEEPVOL?
 Return value: 3

- ◆ **SYSTem:ENV:PASSVOL** Set/query the status of qualified sounds.

--Format:
 Setting format: SYSTem:ENV:PASSVOL
 <TWO/LONG/OFF>or<2/1/0>
 Query format: SYSTem:ENV:PASSVOL?
 --Data < TWO/LONG/OFF >:
 Data type: character
 Data range: OFF(0), LONG(1), TWO(2)
 --Example:
 Set Qualified Sound Status to: LONG
 Setting command: SYSTem:ENV:PASSVOL 1
 Query command: SYSTem:ENV:PASSVOL?
 Return value: 1

◆ **SYSTem:ENV:FAILVOL** Set/query the status of the failed sound.

--Format:
 Setting format: SYSTem:ENV:FAILVOL
 <TWO/LONG/OFF>or<2/1/0>
 Query format: SYSTem:ENV:FAILVOL?
 --Data < TWO/LONG/OFF >:
 Data type: character
 Data Range: OFF(0), LONG(1), TWO(2)
 --Example:
 Set the failed sound status to: LONG
 Setting command: SYSTem:ENV:FAILVOL 1
 Query command: SYSTem:ENV:FAILVOL?
 Return value: 1

◆ **SYSTem:ENV:LANGuAge** Set/query the status of a languAge.

--Format:
 Setting format: SYSTem:ENV:LANGuAge <1/0>
 Query format: SYSTem:ENV:LANGuAge?
 --Data <1/0>:
 Data type: character
 Data range: 0 (Chinese), 1 (English)
 --Example:
 Set the languAge status to: Chinese
 Setting command: SYSTem:ENV:LANGuAge 0
 Query command: SYSTem:ENV:LANGuAge?
 Return value: 0

◆ **SYSTem:ENV:KEYLOCK** Set/query the setting status of key lock.

--Format:
 Setting format: SYSTem:ENV:KEYLOCK <state value>
 Query format: SYSTem:ENV:KEYLOCK?
 --Data<status value>:
 Data type: character
 Data range: 0/1 (0: manual, 1: bus)
 --Example:

Set the key lock status to: Manual
Setting command: SYSTem:ENV:KEYLOCK 0
Query command: SYSTem:ENV:KEYLOCK?
Return value: 0

- ◆ **SYSTem:ENV:KEYLOCK:UNLOCK** Unlock the key lock state.
 - Example:
Unlock the key lock state under the bus unlock setting condition
Setting command: SYSTem:ENV:KEYLOCK:UNLOCK

- ◆ **SYSTem:ENV:BRiGht** Set/query the display backlight brightness status.
 - Format:
Setting format: SYSTem:ENV:BRiGht <brightness value>
Query format: SYSTem:ENV: BRiGht ?
 - Data<brightness value>:
Data type: integer
Data range: 20~100
 - Example:
Set the display backlight brightness to: 50
Setting command: SYSTem:ENV:BRiGht 5 0
Query command: SYSTem:ENV:BRiGht?
Return value: 50

- ◆ **SYSTem:ENV:SOFTKEY** Set/query the setting status of the software keypad.
 - Format:
Setting format: SYSTem:ENV:SOFTKEY <state value>
Query format: SYSTem:ENV: SOFTKEY?
 - Data<status value>:
Data type: character
Data range: 0/1 (0: off, 1: on)
 - Example:
Set the software keyboard status to: Off
Setting command: SYSTem:ENV: SOFTKEY 0
Query command: SYSTem:ENV: SOFTKEY?
Return value: 0

- ◆ **SYSTem:ENV:DATE** Set/query the system date.
 - Format:
Setting format: SYSTem:ENV:DATE <year, month and day>
Query format: SYSTem:ENV:DATE?
 - Data <year, month, and day>:
Data type: character
Data range: 2017 1 1~9999 12 31
 - Example:
Set the system date to: November 17, 2021
Setting command: SYSTem:ENV:DATE 2021 11 17
Query command: SYSTem:ENV:DATE?

Return value: 2021,11,17

- ◆ **SYSTEM:ENV:TIME** Set/query the system time.

--Format:

Setting format: SYSTEM:ENV:TIME <hour, minute, second>.

Query format: SYSTEM:ENV:TIME?

--Data <hour, minute, second>:

Data type: character

Data range: 0 0 0 ~ 23 59 59

--Example:

Set the system time to: 16:23:23

Setting command: SYSTEM:ENV:TIME 16 23 23

Query command: SYSTEM:ENV:TIME?

Return value: 16,23,23

4.2.5 MMEM Subsystem Command Set

- ◆ **MMEM:NEW** Create a new folder with the specified <folder name>.

--Format:

Setting format: MMEM:NEW <folder name>

--Data <folder name>:

Data type: character (case sensitive)

Return value: OK

--Example:

Set the new folder name: TH9130test

Setting command: MMEM:NEW TH9130test

- ◆ **MMEM:DEL** Delete the internal folder specified by the folder name.

--Format:

Setting format: MMEM:DEL <folder name>

--Data <folder name>:

Data type: character (case-sensitive)

--Example:

Set the deletion folder name: TH9130TEST

Setting command: MMEM:DEL TH9130TEST

Return value: OK for successful deletion, ERROR for failed deletion.

- ◆ **MMEM:RENAME** Rename the internal folder specified by folder name.

--Format:

Setting format: MMEM:RENAME <original folder name> <new folder name>

The "_" above indicates a space.

--Data <original folder name>/<new folder name>:

Data type: character (case sensitive)

--Example:

Set the original folder name TH9130TEST renamed to: th9130test

Setting command: MMEM:RENAME th9130test th9130test

Return value: OK for success, ERROR for failure.

- ◆ **MMEM:COPY** Copy internal files specified by folder name to external storage.
 - Format:
 - Setting format: MMEM:COPY <folder name>
 - Data <folder name>:
 - Data type: character
 - Example:
 - Set the copy folder name: TH9130TEST
 - Setting command: MMEM:COPY TH9130TEST
 - Return value: OK for successful copying, ERROR for failed copying.

- ◆ **MMEM:NEW** Create a new file with the specified <filename>.
 - Format:
 - Setting format: MMEM:NEW <filename>.sta
 - Data<filename>:
 - Data type: character (case sensitive)
 - Return value: OK
 - Example:
 - Set the new file name to: TH9130test
 - Setting command: MMEM:NEW TH9130test.sta

- ◆ **MMEM:DEL** Delete the internal file specified by the filename.
 - Format:
 - Setting format: MMEM:DEL <filename>.sta
 - Data<filename>:
 - Data type: character (case sensitive)
 - Example:
 - Set the deletion file name to: TH9130TEST
 - Setting command: MMEM:DEL TH9130TEST.sta
 - Return value: OK for successful deletion, ERROR for failed deletion.

- ◆ **MMEM:RENAME** Rename the internal file specified by filename.
 - Format:
 - Setting format: MMEM:RENAME <original filename>.sta <new filename>.sta
 - The "_" above indicates a space.
 - Data <original filename>/<new filename>:
 - Data type: character (case sensitive)
 - Example:
 - Set the original filename TH9130TEST to rename to: th9130test
 - Setting command: MMEM:RENAME TH9130TEST.sta th9130test.sta
 - Return value: OK for success, ERROR for failure.

- ◆ **MMEM:COPY** Copy the internal file specified by the filename to external storage.

--Format:

Setting format: MMEM:COPY <filename>. <file format>.

--Data <filename>/<file format>:

Data type: character

--Example:

Set the copy file name to: TH9130TEST

Setting command: MMEM:COPY TH9130TEST.sta

Return value: OK for successful copying, ERROR for failed

copying.

- ◆ **MMEM:SAVE** Save the current settings to a file stored internally as <filename>

--Format:

Setting format: MMEM:SAVE <filename>.sta

--Data<filename>:

Data type: character

Return value: OK

--Example:

Set the save file name to: TH9130TEST

Setting command: MMEM:SAVE TH9130TEST.sta

- ◆ **MMEM:LOAD** Load the internal file specified by filename into the current.

--Format:

Setting format: MMEM:LOAD <filename>.sta

--Data<filename>:

Data type: character

--Example:

Set the load file name to: TH9130TEST

Setting command: MMEM:LOAD TH9130TEST.sta

Return value: OK for successful loading, ERROR for failed loading.

- ◆ **MMEM:LIST** Display all .sta files in internal files.

--Format:

Query the specified folder format:MMEM:LIST <path to folder

in root file>

Query root folder format:MMEM:LIST?

--Data <path of folder in root file>:

Data type: character

--Example:

Query all .sta files in the STA folder under the root file

Setting command: MMEM:LIST STA

Return value: example.sta; if there is no query folder, return

ERROR

4.2.6 USB Subsystem Command Set

- ◆ **USB:NEW** Create a new folder with the specified <folder name>.

--Format:

Setting Format: USB:NEW <folder name>

--Data <folder name>:

Data type: character (case sensitive)

Return value: OK

--Example:

Set the new folder name: TH9130test

Setting command: USB:NEW TH9130test

- ◆ **USB:DEL** Delete the external folder specified by the folder name.

--Format:

Setting format: USB:DEL <folder name>

--Data <folder name>:

Data type: character (case sensitive)

--Example:

Set the deletion folder name: TH9130TEST

Setting command: USB:DEL TH9130TEST

Return value: OK for successful deletion, ERROR for failed deletion.

- ◆ **USB:RENAME** Rename the external folder specified by the folder name.

--Format:

Setting format: USB:RENAME <existing folder name> <new folder name>

The "_" above indicates a space.

--Data <original folder name>/<new folder name>:

Data type: character (case sensitive)

--Example:

Set the original folder name TH9130TEST renamed to: th9130test

Setting command: USB:RENAME TH9130TEST th9130test

Return value: OK for success, ERROR for failure.

- ◆ **USB:COPY** Copy the external file specified by the folder name to internal storage.

--Format:

Setting format: USB:COPY <folder name>

--Data <folder name>:

Data type: character

--Example:

Set the copy folder name: TH9130TEST

Setting command: USB:COPY TH9130TEST

copying.

Return value: OK for successful copying, ERROR for failed

- ◆ **USB:NEW** Create a new file with the specified <filename>.

--Format:

Setting format: USB:NEW <filename>.sta

--Data<filename>:

Data type: character (case sensitive)

Return value: OK

--Example:

Set the new file name to: TH9130test

Setting command: USB:NEW TH9130test.sta

◆ **USB:DEL** Delete the external file specified by the filename.

--Format:

Setting format: USB:DEL <filename>.sta

--Data<filename>:

Data type: character (case sensitive)

--Example:

Set the deletion file name to: TH9130TEST

Setting command: USB:DEL TH9130TEST.sta

Return value: OK for successful deletion, ERROR for failed deletion.

◆ **USB:RENAME** Rename the external file specified by the filename.

--Format:

Setting format: USB:RENAME <original file name>.sta <new file name>.sta

The "_" above indicates a space.

--Data <original filename>/<new filename>:

Data type: character (case sensitive)

--Example:

Set the original filename TH9130TEST to rename to: th9130test

Setting command: USB:RENAME TH9130TEST.sta th9130test.sta

Return value: OK for success, ERROR for failure.

◆ **USB:COPY** Copy the external file specified by the filename to internal storage.

--Format:

Setting format: USB:COPY <filename>. <file format>.

--Data <filename>/<file format>:

Data type: character

--Example:

Set the copy file name to: TH9130TEST

Setting command: USB:COPY TH9130TEST.sta

Return value: OK for successful copying, ERROR for failed copying.

◆ **USB:SAVE** Save the current settings to a file stored externally as <filename>.

--Format:

Setting format: USB:SAVE <filename>.sta

--Data<filename>:

Data type: character

Return value: OK

--Example:

Set the save file name to: TH9130TEST

Setting command: USB:SAVE TH9130TEST.sta

- ◆ **USB:LOAD** Load the external file specified by the filename into the current.
 - Format:
 - Setting format: USB:LOAD <filename>.sta
 - Data<filename>:
 - Data type: character
 - Example:
 - Set the load file name to: TH9130TEST
 - Setting command: USB:LOAD TH9130TEST.sta
 - Return value: OK for successful loading, ERROR for failed loading.

- ◆ **USB:LIST** Display all .sta files in the USB file.
 - Format:
 - Query the specified folder format:USB:LIST <path to folder in
USB root file>
 - Query USB root folder format: USB:LIST?
 - Data<Path of folder in USB root file>:
 - Data type: character
 - Example:
 - Query all .sta files in the STA folder under the USB root file
 - Setting command: USB:LIST STA
 - Return value: example.sta; if there is no query folder, return
ERROR

4.2.7 FETCh Subsystem Command Set

The FETCh subsystem Command set is used to obtain measurements from the instrument and is issued after initiating a test until the test is completed or interrupted by other Commands.

- ◆ **FETCh:AUTO** Set/query the status of Automatic return of measurement results.
 - Format:
 - Setting format: FETCh:AUTO <ON/OFF/EOM>or<1/0/2>
 - Query Format: FETCh:AUTO?
 - Data <ON/OFF/EOM>:
 - Data type: character
 - Data range: OFF (0), indicating that real-time Automatic return of
measurement data is turned off
 - ON (1), indicates that real-time Automatic return of measurement
data is turned on
 - EOM (2), which indicates that the measurement results are
Automatically returned at the end of measurement
 - Example:
 - Set the Automatic return of measurement results to: ON
 - Setting command: FETCh:AUTO ON
 - Query command: FETCh:AUTO?
 - Return value: ON

- ◆ **FETCh?** Output the results of instrument measurements.

Command Syntax: FETCh? When the instrument receives this Command, the instrument Automatically sends out the test results of all steps until the test is finished.

Return format: Test steps: test mode, actual test voltage (kV), actual measured current (A), test conclusion.

Test steps: test mode, actual test voltage (kV), actual measurement resistance (Ω), test conclusion.

Test steps: test mode, actual test current (A), actual measurement resistance (Ω), test conclusion.

Test steps: test mode, actual measured resistance (Ω), test conclusion.

Test steps: test mode, voltage (V), current (A), power (W), figure of merit, leakage current (μA), conclusion.

Test steps: test mode, source voltage (V), MD voltage (mV), leakage current (μA), maximum leakage current (μA), conclusion.

Test steps: test mode, actual measured capacitance (F), test conclusion.

Example: STEP 1:AC,1.000,1.000e-3, PASS.

STEP 2:IR,1.500,1.000e+7, PASS.

STEP 3:GB, 2.500e+1, 1.000e-1, PASS.

STEP 4:CONT,9.000e+2, PASS.

STEP 5:RUN,220.0,2.000,440.0,1.000,1.000, PASS; (only available for TH9130/TH9131)

STEP6:LC,230.0,3000.0,3000.000,3006.000, PASS; (only available for TH9130/TH9131)

Test steps: 1, Test Mode: AC, Test Voltage 1kV, Test Current 1mA, Test Conclusion: PASS.

Test steps: 2,Test Mode: IR,Test Voltage: 1.5kV,Test Resistance: 10M Ω ,Test Conclusion: PASS.

Test steps: 3,Test Mode: GB,Test Current: 25A,Test Resistance: 100m Ω ,Test Conclusion: PASS.

Test steps: 4,Test Mode: CONT, Actual Test Resistance 900 Ω ,Test Conclusion: PASS.

Test steps: 5, Test mode: RUN, Test Voltage 220V, Current 2A, Power 440W, Power Factor 1.000, Leakage Current 1mA, Test Conclusion: PASS; (only available for TH9130/TH9131)

Test steps: 6, Test Mode: LC, Power Supply Voltage 230V, MD Voltage 3000mV, Leakage Current 3000 μA , Maximum Leakage Current 3006 μA , Test Conclusion: PASS; (Only available for TH9130/TH9131)

Note: By default, the instrument will Automatically return the results of each measurement (each step of the test results).

4.2.8 Other Control Command Sets



*IDN? Query the instrument model and version information.

Query return: <manufacturer>,<model>,<firmware><NL^END>.

Here:

<manufacturer> Give the name of the manufacturer (i.e. Tonghui)

<model> Give the model number of the machine (e.g.

TH9130/TH9130A)

<firmware> Give the software version number (e.g. Ver1.0 2)

Example:*IDN?

Return: Tonghui,TH9130,Ver1.02

FUNC:START Start the test

FUNC:START <num> Start the specified step test in single-step mode

*STOP Stop the test

Chapter 5 Technical Indicators

Model		TH9130/TH9130A		TH9131/TH9131A		
Pressure resistance test						
Output voltage	AC	Voltage range	0.05-5.0kV			
		Voltage Waveform	50/60Hz \pm 0.1% sine wave			
		Output power	500VA (5.0kV 100mA)	200VA (5.0kV 40mA)		
	DC	Voltage range	0.05-6.0kV			
		Output power	150VA (6.0kV 25mA)	120VA (6.0kV 20mA)		
	Load variability		\pm (1% setpoint + 10V) (rated power)			
Voltage Resolution		2V				
Voltage Accuracy		\pm (1% setpoint + 5V)				
Current test	AC	Current range	0.001mA-120mA (voltage \leq 4kV)	0.001mA-40mA		
			0.001mA-100mA (voltage >4kV)			
		Resolution	0.001mA			
		Current Accuracy	120mA: 0.1mA-120.0mA \pm (1% reading + 0.6mA)	40mA: 0.1mA-40.0mA \pm (1% of reading + 0.6mA)		
			30mA: 0.01mA-29.99mA \pm (1% reading + 0.15mA)	3mA: 0.001mA-2.999mA \pm (1% reading + 0.015mA)		
	DC	Current range	0.0001mA-25mA (voltage \geq 1.5kV)	0.0001mA-20mA		
			0.0001mA-20mA (voltage <1.5kV)			
		Resolution	0.1uA			
		Current Accuracy	25mA: 0.01mA-25.00mA \pm (1% of reading + 0.12mA)	20mA: 0.01mA-20.00mA \pm (1% reading + 0.12mA)		
			3mA: 0.001mA-2.999mA \pm (1% reading + 0.015mA)	300uA: 0.1uA-299.9uA \pm (1% of reading + 1.5uA)		
Time setting	Testing time	0.3~999s, 0 means continuous test				
	Rising time	0.1~999s, 0 means off				
	Falling time	0.1~999s, 0 means off				
	Waiting time	0.1 to 999s, 0 means off (DC withstand voltage only)				
Arc detection		AC: 1.0mA-20.0mA DC: 1.0mA-10.0mA				
Maximum short-circuit current		200mA (AC test only)	80mA (AC test only)			
Rapid Discharge Function		Automatic discharge at the end of the test (DCW)				
Insulation resistance test						
Output voltage		DC:0.05-6.0kV				
Voltage Resolution		2V				
Voltage Accuracy		\pm (1% setpoint + 5V)				
Resistance Test Range		0.05M Ω - 50.0G Ω				
Resistance Test Accuracy		Voltage \geq 1kV	1M Ω -1G Ω \pm (3% of reading + 1M)			
			1G Ω -10G Ω \pm (7% of reading + 0.2G)			

		10GΩ-50GΩ ± (10% of reading + 0.5G)	
	Voltage	0.05MΩ-1GΩ ± (3% of reading + 1M)	
	500V-1kV	1GΩ-10GΩ ± (7% of reading + 0.2G)	
		10GΩ-50GΩ ± (10% of reading + 0.5G)	
	Voltage <500V	1MΩ-1GΩ ± (5% of reading + 100V/Vs*10M)	
Time setting	Testing time	0.3~999s, 0 means continuous test	
	Rising time	0.1~999s, 0 means off	
	Falling time	0.1~999s, 0 means off	
	Waiting time	0.1~999s, 0 means off	
Rapid Discharge Function		Automatic discharge at the end of the test	
AC Ground Resistance Testing			
Output Current	Current range	1.00-40.00A	
	Current resolution	0.01A	
	Current Accuracy	± (2% of setpoint + 2 words)	
Test voltage	Voltage range	3.00-8.00V	
	Voltage resolution	0.01V	
	Voltage Accuracy	± (2% of setpoint + 3 words)	
Test Frequency		50/60Hz ± 0.1%	
Output Adjustment Rate		± (1% of output value +0.02A)	
Resistance Test Range	1.00-10.00A	0-600mΩ	
	10.01-30.00A	0-200 mΩ	
	30.01-40.00A	0-150 mΩ	
Resistance Test Accuracy	1.00-3.00A	0-600 mΩ ± (3% of reading + 3 words)	
	3.01-10.00A	0-600 mΩ ± (2% of reading + 2 words)	
	10.01-30.00A	0-200 mΩ ± (2% of reading + 2 words)	
	30.01-40.00A	0-150 mΩ ± (2% of reading + 2 words)	
Testing time		0.5~999s, 0 means continuous test	
Conductivity Test			
Test Current	0.1A	0.00-10.00Ω	
	0.01A	10.1-100.0Ω	
	0.001A	101-1000Ω	
	0.0001A	1001-10000Ω	
Resistance Test Accuracy	0-1000Ω	± (1% of reading + 3 words)	
	1001-10000Ω	± (1% of reading + 10 words)	
Testing time		0.3-999s, 0 for continuous testing	
Electrical testing (only available for TH9130/TH9131)			
Voltage Measurement Range, Resolution and Accuracy	0.0-277.0V	0.1V	± (1.5% of reading + 2 words) (30-277V)
Current Measurement Range, Resolution and Accuracy	0.00-16.00A	0.01A	± (2% of reading + 2 words)
Power Measurement Range,	0-4500W	1W	± (5% of reading + 3W)

Resolution and Accuracy			
Power factor range, resolution and accuracy	0.000-1.000	0.001	± (8% of reading + 2 words)
Leakage current range, resolution and accuracy	0.00-10.00mA	0.01mA	± (2% of reading + 2 words)
Testing time	0.1-999s, 0 means continuous test		
Waiting time	0.2-999s		
Leakage current test (only available for TH9130/TH9131)			
DUT power supply range and accuracy	0-277Vac, 16Aac max		± (1.5% of reading + 2 words) (30-277V)
Leakage current test range	0.0uA-10.00mA		
Leakage current test frequency range	DC, 15Hz-1MHz		
Testing time	AC+DC: 0.5-999s AC/DC: 0.1-999s 0 indicates continuous test		
Waiting time	AC+DC	0.5-999s	
	AC/DC	1.8-999s Auto range 1.3-999s Fixed range	
Human Impedance Network MD	A: UL544NP、UL484、UL1363、UL923、UL471、UL867、UL697		
	B: UL544P		
	C: GB9706.1, UL2601-1, IEC60601-1, EN60601-1		
	D: UL1563		
	E: GB/T12113, GB4943.1, GB4706.1, GB31897.1, GB7000.1, GB/T42125.1, GB4793.1, IEC60990 Fig4 U2, IEC60950-1, IEC60335-1, IEC60598-1, UL484, IEC60065, IEC61010		
	F: GB/T12113, GB4943.1, GB31897.1, GB7000.1, IEC60990 Fig5 U3, IEC60598-1		
	G: Frequency detection 1kΩ		
	H: GB4793.1, GB/T42125.1, IEC61010-1		
MD A-G Device Accuracy	Resistance accuracy ±1% Capacitance accuracy ±5		
MD Voltage Protection	30V peak or 30Vdc		
Probe Settings	G-l, ph-l, ph-pl		
Leakage current range (RMS)			
Auto range	MD main resistance of 0.5 kΩ	MD main resistance is 1kΩ	MD main resistance of 1.5 kΩ
Range 1	0.0uA - 64.0uA	0.0uA - 32.0uA	0.0uA - 22.0uA
Range 2	56.0uA - 260.0uA	28.0uA - 130.0uA	18.3uA - 85.0uA
Range 3	240.0uA - 999.9uA 1000uA - 1050uA	120.0uA - 525.0uA	80.0uA - 350.0uA
Range 4	800.0uA - 999.9uA 1000uA - 4200uA	400.0uA - 999.9uA 1000uA - 2100uA	266.6uA - 999.9uA 1000uA - 1400uA
Range 5	3600uA - 8399uA 8.40mA - 10.00mA	1800uA - 8400uA	1200uA - 5600uA
Range 6	---	8000uA - 8399uA 8.40mA - 10.00mA	5300uA - 8399uA 8.40mA - 10.00mA
Fixed range	MD main resistance	MD main resistance is	MD main resistance of 1.5

(>6% of range)	of 0.5 kΩ	1kΩ	kΩ
Range 1	0.0uA - 64.0uA	0.0uA - 32.0uA	0.0uA - 22.0uA
Range 2	15.6uA - 260.0uA	7.8uA - 130.0uA	5.1uA - 85.0uA
Range 3	63uA - 1050uA	31.5uA - 525.0uA	21.0uA - 350.0uA
Range 4	252uA - 4200uA	126uA - 2100uA	84uA - 1400uA
Range 5	600uA - 8399uA 8.40mA - 10.00mA	504uA - 8400uA	336uA - 5600uA
Range 6	600uA - 8399uA 8.40mA - 10.00mA	600uA - 8399uA 8.40mA - 10.00mA	600uA - 8399uA 8.40mA - 10.00mA
Fixed range (<6% of range)	MD main resistance of 0.5 kΩ	MD main resistance is 1kΩ	MD main resistance of 1.5 kΩ
Range 1	---	---	---
Range 2	0.0uA - 15.6uA	0.0uA - 7.8uA	0.0uA - 5.1uA
Range 3	0uA - 63uA	0.0uA - 31.5uA	0.0uA - 21.0uA
Range 4	0uA - 252uA	0uA - 126uA	0uA - 84uA
Range 5	0uA - 600uA	0uA - 504uA	0uA - 336uA
Range 6	0uA - 600uA	0uA - 600uA	0uA - 600uA
Resolution			
Auto-range& fixed range 1-2 & fixed range 3 (1k&1.5k MD)	<1000uA	0.1uA	
	1000uA - 8400uA	1uA	
	>8400uA	0.01mA	
Fixed range3 (0.5k MD) & fixed range 4-6	<8400uA	1uA	
	>8400uA	0.01mA	
Auto range accuracy			
Range	Test pattern	Frequency	Accurate
Range 1-5	AC+DC	DC	± (2% of reading + 3 words)
		15Hz<f<100khz	± (2% of reading + 3 words)
		100khz≤f≤1mhz	± (5% of reading) >10.0uA
	AC only	15Hz<f≤30Hz	± (3% of of reading + 5 words)
		30Hz<f<100khz	± (2% of reading + 3 words)
		100khz≤f≤1mhz	± (5% of reading) >10.0uA
DC only	DC	± (2% of reading + 3 words) > 10.0uA	
Range 6	AC+DC	DC	± (5% of reading) >10.0uA
		15Hz<f<100khz	
	AC only	15Hz<f≤30Hz	
		30Hz<f<100khz	
	DC only	DC	
Fixed range accuracy			
Range	Test pattern	Frequency	Accuracy (>6% of Additional error

			range)	(<6% of range)
Range 1-5	AC+DC	DC	\pm (2% of reading + 3 words)	+ (2% of reading + 0.2% of range)
		15Hz<f<100khz	\pm (2% of reading + 3 words)	+ (2% of reading + 0.2% of range)
		100khz≤f≤1mhz	\pm (5% of reading) >10.0uA	+ (2% of reading + 0.5% range)
	AC only	15Hz<f≤30Hz	\pm (3% of reading + 5 words)	+ (2% of reading + 0.2% of range)
		30Hz<f<100khz	\pm (2% of reading + 3 words)	+ (2% of reading + 0.2% of range)
		100khz≤f≤1mhz	\pm (5% of reading) >10.0uA	+ (2% of reading + 0.5% range)
DC only	DC	\pm (2% of reading + 3 words) > 10.0uA	+ (2% of reading + 0.2% of range)	
Range 6	AC+DC	DC	\pm (5% of reading) >10.0uA	+ (2% of reading + 0.2% of range)
		15Hz<f<100khz		
	AC only	15Hz<f≤30Hz		
		30Hz<f<100khz		
DC only	DC			
Leakage current range (peak PEAK)				
Auto range	MD main resistance of 0.5 kΩ	MD main resistance is 1kΩ	MD main resistance of 1.5 kΩ	
Range 1	0.0uA - 64.0uA	0.0uA - 32.0uA	0.0uA - 22.0uA	
Range 2	56.0uA - 260.0uA	28.0uA - 130.0uA	18.3uA - 85.0uA	
Range 3	240.0uA - 999.9uA 1000uA - 1050uA	120.0uA - 525.0uA	80.0uA - 350.0uA	
Range 4	800.0uA - 999.9uA 1000uA - 4200uA	400.0uA - 999.9uA 1000uA - 2100uA	266.6uA - 999.9uA 1000uA - 1400uA	
Range 5	3600uA - 8399uA 8.40mA - 10.00mA	1800uA - 8400uA	1200uA - 5600uA	
Range 6	---	8000uA - 8399uA 8.40mA - 10.00mA	5300uA - 8399uA 8.40mA - 10.00mA	
Fixed range (>6% of range)	MD main resistance of 0.5 kΩ	MD main resistance is 1kΩ	MD main resistance of 1.5 kΩ	
Range 1	0.0uA - 64.0uA	0.0uA - 32.0uA	0.0uA - 22.0uA	
Range 2	15.6uA - 260.0uA	7.8uA - 130.0uA	5.1uA - 85.0uA	
Range 3	63uA - 1050uA	31.5uA - 525.0uA	21.0uA - 350.0uA	
Range 4	252uA - 4200uA	126uA - 2100uA	84uA - 1400uA	
Range 5	600uA - 8399uA 8.40mA - 10.00mA	504uA - 8400uA	336uA - 5600uA	
Range 6	600uA - 8399uA 8.40mA - 10.00mA	1200uA - 8399uA 8.40mA - 10.00mA	1200uA - 8399uA 8.40mA - 10.00mA	
Fixed range	MD main resistance	MD main resistance is	MD main resistance of 1.5	

(<6% range)	of 0.5 kΩ	1kΩ	kΩ	
Range 1	---	---	---	
Range 2	0.0uA - 15.6uA	0.0uA - 7.8uA	0.0uA - 5.1uA	
Range 3	0uA - 63uA	0.0uA - 31.5uA	0.0uA - 21.0uA	
Range 4	0uA - 252uA	0uA - 126uA	0uA - 84uA	
Range 5	0uA - 600uA	0uA - 504uA	0uA - 336uA	
Range 6	0uA - 600uA	0uA - 600uA	0uA - 600uA	
Resolution				
Auto-range & fixed range 1-2 & fixed range 3 (1k&1.5k MD)	<1000uA	0.1uA		
	1000uA - 8400uA	1uA		
	>8400uA	0.01mA		
Fixed range3 (0.5k MD) & fixed range 4-6	<8400uA	1uA		
	>8400uA	0.01mA		
Auto range accuracy				
Range	Test pattern	Frequency	Accurate	
Range 1-5	AC+DC	DC	± (2% of reading + 2uA)	
		15Hz≤f≤1mhz	± (10% of reading + 2uA)	
	AC only	15Hz<f<1mhz	± (10% of reading + 2uA)	
Range 6	AC+DC	DC	± (2% of reading + 3 words)	
		15Hz<f<100khz	± (10% of reading + 2 words)	
	AC only	15Hz<f<100khz	± (10% of reading + 2 words)	
Fixed range accuracy				
Range	Test pattern	Frequency	Accuracy (>6% of range)	Additional error (<6% of range)
Range 1-5	AC+DC	DC	± (2% of reading + 2uA)	+ (2% of reading + 0.2% of range)
		15Hz<f<100khz	± (10% of reading + 2uA)	+ (2% of reading + 0.2% of range)
		100khz≤f≤1mhz	± (10% of reading + 2uA)	+ (2% of reading + 0.5% range)
	AC only	15Hz<f<100khz	± (10% of reading + 2uA)	+ (2% of reading + 0.2% of range)
		100khz<f<1mhz	± (10% of reading + 2uA)	+ (2% of reading + 0.5% range)
Range 6	AC+DC	DC	± (2% of reading + 3 words)	+ (2% of reading + 0.2% of range)
		15Hz<f<100khz	± (10% of reading + 2 words)	
	AC only	15Hz<f<100khz	± (10% of reading + 2 words)	
Leakage Voltage Range (RMS)				

Auto range	MD main resistance of 0.5 kΩ	MD main resistance is 1kΩ	MD main resistance of 1.5 kΩ
Range 1	0.0mv - 32.0mv	0.0mv - 32.0mv	0.0mv - 32.0mv
Range 2	28.0 mv - 130.0mv	28.0 mv - 130.0mv	28.0 mv - 130.0mv
Range 3	120.0mv - 525.0mv	120.0mv - 525.0mv	120.0mv - 525.0mv
Range 4	400.0mv - 999.9mv 1000mv - 2100mv	400.0mv - 999.9mv 1000mv - 2100mv	400.0mv - 999.9mv 1000mv - 2100mv
Range 5	1800mv - 5000mv	1800mv - 8400mv	1800mv - 8400mv
Range 6	---	8000mv - 8399mv 8.40V - 10.00V	8000mv - 8399mv 8.40V - 15.00V
Fixed range (>6% of range)	MD main resistance of 0.5 kΩ	MD main resistance is 1kΩ	MD main resistance of 1.5 kΩ
Range 1	0.0mv - 32.0mv	0.0mv - 32.0mv	0.0mv - 32.0mv
Range 2	7.8mv - 130.0mv	7.8mv - 130.0mv	7.8mv - 130.0mv
Range 3	31.5mv - 525.0mv	31.5mv - 525.0mv	31.5mv - 525.0mv
Range 4	126mv - 2100mv	126mv - 2100mv	126mv - 2100mv
Range 5	300mv - 5000mv	504mv - 8400mv	504mv - 8400mv
Range 6	300mv - 5000mv	600mv - 8399mv 8.40V - 10.00V	900mv - 8399mv 8.40V - 15.00V
Fixed range (<6% of range)	MD main resistance of 0.5 kΩ	MD main resistance is 1kΩ	MD main resistance of 1.5 kΩ
Range 1	---	---	---
Range 2	0.0mv - 7.8mv	0.0mv - 7.8mv	0.0mv - 7.8mv
Range 3	0.0mv - 31.5mv	0.0mv - 31.5mv	0.0mv - 31.5mv
Range 4	0mv - 126mv	0mv - 126mv	0mv - 126mv
Range 5	0mv - 300mv	0mv - 504mv	0mv - 504mv
Range 6	0mv - 300mv	0mv - 600mv	0mv - 900mv
Resolution			
Auto-Ranging & Fixed range 1-2 & Fixed range 3 (1k&1.5k MD)	<1000mv	0.1mv	
	1000mv - 8400mv	1mv	
	>8400mv	0.01V	
Fixed range3 (0.5k MD) & Fixed range 4-6	<8400mv	1mv	
	>8400mv	0.01V	
Auto range accuracy			
Range	Test pattern	Frequency	Accurate
Range 1-5	AC+DC	DC	± (2% of reading + 3 words)
		15Hz<f<100khz	± (2% of reading + 3 words)
		100khz≤f≤1mhz	± (5% of reading) >10.0mv
	AC only	15Hz<f≤30Hz	± (3% of reading + 5 words)

		30Hz<f<100khz	± (2% of reading + 3 words)	
		100khz≤f≤1mhz	± (5% of reading) >10.0mv	
	DC only	DC	± (2% of reading + 3 words) > 10.0mv	
Range 6	AC+DC	DC	± (5% of reading) >10.0mv	
		15Hz<f<100khz		
	AC only	15Hz<f≤30Hz		
		30Hz<f<100khz		
DC only	DC			
Fixed range accuracy				
Range	Test pattern	Frequency	Accuracy (>6% of range)	Additional error (<6% of range)
Range 1-5	AC+DC	DC	± (2% of reading + 3 words)	+ (2% of reading + 0.2% of range)
		15Hz<f<100khz	± (2% of reading + 3 words)	+ (2% of reading + 0.2% of range)
		100khz≤f≤1mhz	± (5% of reading) >10.0mv	+ (2% of reading + 0.5% of range)
	AC only	15Hz<f≤30Hz	± (3% of reading + 5 words)	+ (2% of reading + 0.2% of range)
		30Hz<f<100khz	± (2% of reading + 3 words)	+ (2% of reading + 0.2% of range)
		100khz≤f≤1mhz	± (5% of reading) >10.0mv	+ (2% of reading + 0.5% of range)
DC only	DC	± (2% of reading + 3 words) > 10.0mv	+ (2% of reading + 0.2% of range)	
Range 6	AC+DC	DC	±(5% of reading) >10.0mv	+ (2% of reading + 0.2% of range)
		15Hz<f<100khz		
	AC only	15Hz<f≤30Hz		
		30Hz<f<100khz		
DC only	DC			
Leakage voltage range (peak PEAK)				
Auto range	MD main resistance of 0.5 kΩ	MD main resistance is 1kΩ	MD main resistance of 1.5 kΩ	
Range 1	0.0mv - 32.0mv	0.0mv - 32.0mv	0.0mv - 32.0mv	
Range 2	28.0 mv - 130.0mv	28.0 mv - 130.0mv	28.0 mv - 130.0mv	
Range 3	120.0mv - 525.0mv	120.0mv - 525.0mv	120.0mv - 525.0mv	
Range 4	400.0mv - 999.9mv	400.0mv - 999.9mv	400.0mv - 999.9mv	
	1000mv - 2100mv	1000mv - 2100mv	1000mv - 2100mv	
Range 5	1800mv - 5000mv	1800mv - 8400mv	1800mv - 8400mv	
Range 6	---	8000mv - 8399mv	8000mv - 8399mv	
		8.40V - 10.00V	8.40V - 15.00V	
Fixed range (>6% of range)	MD main resistance of 0.5 kΩ	MD main resistance is 1kΩ	MD main resistance of 1.5 kΩ	

Range 1	0.0mv - 32.0mv	0.0mv - 32.0mv	0.0mv - 32.0mv	
Range 2	7.8mv - 130.0mv	7.8mv - 130.0mv	7.8mv - 130.0mv	
Range 3	31.5mv - 525.0mv	31.5mv - 525.0mv	31.5mv - 525.0mv	
Range 4	126mv - 2100mv	126mv - 2100mv	126mv - 2100mv	
Range 5	300mv - 5000mv	504mv - 8400mv	504mv - 8400mv	
Range 6	300mv - 5000mv	600mv - 8399mv 8.40V - 10.00V	900mv - 8399mv 8.40V - 15.00V	
Fixed range (<6% of range)	MD main resistance of 0.5 kΩ	MD main resistance is 1kΩ	MD main resistance of 1.5 kΩ	
Range 1	---	---	---	
Range 2	0.0mv - 7.8mv	0.0mv - 7.8mv	0.0mv - 7.8mv	
Range 3	0.0mv - 31.5mv	0.0mv - 31.5mv	0.0mv - 31.5mv	
Range 4	0mv - 126mv	0mv - 126mv	0mv - 126mv	
Range 5	0mv - 300mv	0mv - 504mv	0mv - 504mv	
Range 6	0mv - 300mv	0mv - 600mv	0mv - 900mv	
Resolution				
Auto-rang & fixed range 1-2 & fixed range 3 (1k&1.5k MD)	<1000mv	0.1mv		
	1000mv - 8400mv	1mv		
	>8400mv	0.01V		
Fixed range 3 (0.5k MD) & fixed range 4-6	<8400mv	1mv		
	>8400mv	0.01V		
Auto range accuracy				
Range	Test pattern	Frequency	Accurate	
Range 1-5	AC+DC	DC	± (2% of reading + 2mv)	
		15Hz≤f≤1mhz	± (10% of reading + 2mv)	
	AC only	15Hz<f<1mhz	± (10% of reading + 2mv)	
Range 6	AC+DC	DC	± (2% of reading + 3 words)	
		15Hz<f<100khz	± (10% of reading + 2 words)	
	AC only	15Hz<f<100khz	± (10% of reading + 2 words)	
Fixed range accuracy				
Range	Test pattern	Frequency	Accuracy (>6% of range)	Additional error (<6% of range)
Range 1-5	AC+DC	DC	± (2% of reading + 2mv)	+ (2% of reading + 0.2% of range)
		15Hz<f<100khz	± (10% of reading + 2mv)	+ (2% of reading + 0.2% of range)
		100khz≤f≤1mhz	± (10% of reading + 2mv)	+ (2% of reading + 0.5% of range)
	AC only	15Hz<f<100khz	± (10% of reading + 2mv)	+ (2% of reading + 0.2% of range)

		100kHz<f<1mhz	± (10% of reading + 2mv)	+ (2% of reading + 0.5% of range)
Range 6	AC+DC	DC	± (2% of reading + 3 words)	+ (2% of reading + 0.2% of range)
		15Hz<f<100kHz	± (10% of reading + 2 words)	
	AC only	15Hz<f<100kHz	± (10% of reading + 2 words)	
OSC open/short circuit detection				
Sampling capacitance range	standard	0.001~40nf		
Open Circuit Judgment Range	10% to 100%			
Short Circuit Judgment Range	100% to 500%			
Safety and security features				
Electrocution protection	0.5mA ± 0.25mA selectable: on or off			
Startup Protection Interlock	High-voltage output is allowed only when the pin is connected low			
Panel operation protection	Key lock			
Warning indication	Pass: short tone, green light; Fail: long tone, red light			
Short-circuit protection for electrical and leakage power supplies (available only for TH9130/TH9131)	23ARMS or inrush current 68APEAK			
Synchronized output test for withstand voltage and grounding	5kVac/50mAac and 30Aac/150mΩ	and	5kVac/30mAac and 30Aac/150mΩ	
Storage and Interfaces				
Internal memory	Up to 100 files can be stored and each file can be edited with 50 steps			
Standard Interface	RS232, USB DEVICE, USB HOST, LAN, HANDLER			
Optional Interfaces	GPIB			
Ambient temperature and humidity				
Parameter comparison temperature	18°C~28°C, Humidity: 30%~70%RH			
Normal working temperature	0°C~45°C, Humidity: 20%~90%RH			
Storage ambient temperature	-10°C~55°C, Humidity:< 80%RH			
General indicators				
Electric power source	100V~240VAC, 47Hz~63Hz			
Power (output)	No load:< 100W Rated power:1200W			
Volumetric	430mm (W) x 132mm (H) x 550mm (D)			
Weights	40kg			

Chapter 6 Appendice

6.1 Warranty

Warranty period: the warranty period of one year shall be calculated from the date of shipment of the instrument purchased from the Company by the user unit, or from the date of shipment of the instrument purchased from the operating department. Warranty should be issued by the instrument warranty card. During the warranty period, if the instrument is damaged due to improper operation by the user, the maintenance cost shall be borne by the user. The instrument is responsible for lifetime maintenance by our company.

The maintenance of this instrument requires professional and technical personnel to carry out maintenance; maintenance, please do not replace the internal components of the instrument without authorization; maintenance of the instrument, the need to re-measure the calibration, so as not to affect the accuracy of the test. Due to the user blind maintenance, replacement of instrument components caused by damage to the instrument is not covered by the warranty, the user should bear the maintenance costs.

The instrument should be protected from sunlight and humidity and should be used properly in the environment described in 1.2. 2.

When the instrument is not used for a long period of time, it should be sealed in the factory box.

6.2 Manual Change Instructions

Version History

This manual will be continually improved for ease of use.

Due to possible errors or omissions in the instruction manual, improvement and refinement of the instrument's functions, technological updates and software upgrades, the manual will be adjusted and revised accordingly.

Please pay attention to the version of the software you are using and the version of the manual.

- | | | |
|----|----------------------------------|----------------|
| 1. | April 2022 | First Edition |
| 2. | November 2022 | Second Edition |
| | Modify catalog page number | |
| 3. | November 2022 | Third Edition |
| | Modification Panel Introduction | |
| | Add new Commands | |
| 4. | March 2023 | |
| | Modify leakage circuit schematic | |

Modifying the MD Selection Screen

- 5. June 2023 Fifth Edition
 - Modification of IR specifications
 - Revise the format of some of the instructions
- 6. August 2023 Sixth Edition
 - Modification of IR specifications
 - Modification of some instructions
 - Screenshot of the new interface
 - Modify the format of the manual
- 7. September 2023 Seventh Edition
 - IR add delay time
- 8. March 2024 Eighth Edition
 - Addition of human impedance modeling and national standard numbers to leakage current testing

⚠️ **DISCLAIMER:** The Company may make improvements and enhancements to the performance, functions, software, structure, appearance, accessories, packaging, and manuals of this product without prior notice! If this causes any doubt, please contact our company.